

Joint Capability Area (JCA) (O/2 Capability Taxonomy)

System Architect



Joint Capability
Area



Force Support



Battlespace
Awareness



Force
Application



Logistics



Command and
Control



Net-Centric



Protection



Building
Partnerships



Corporate
Management
and Support



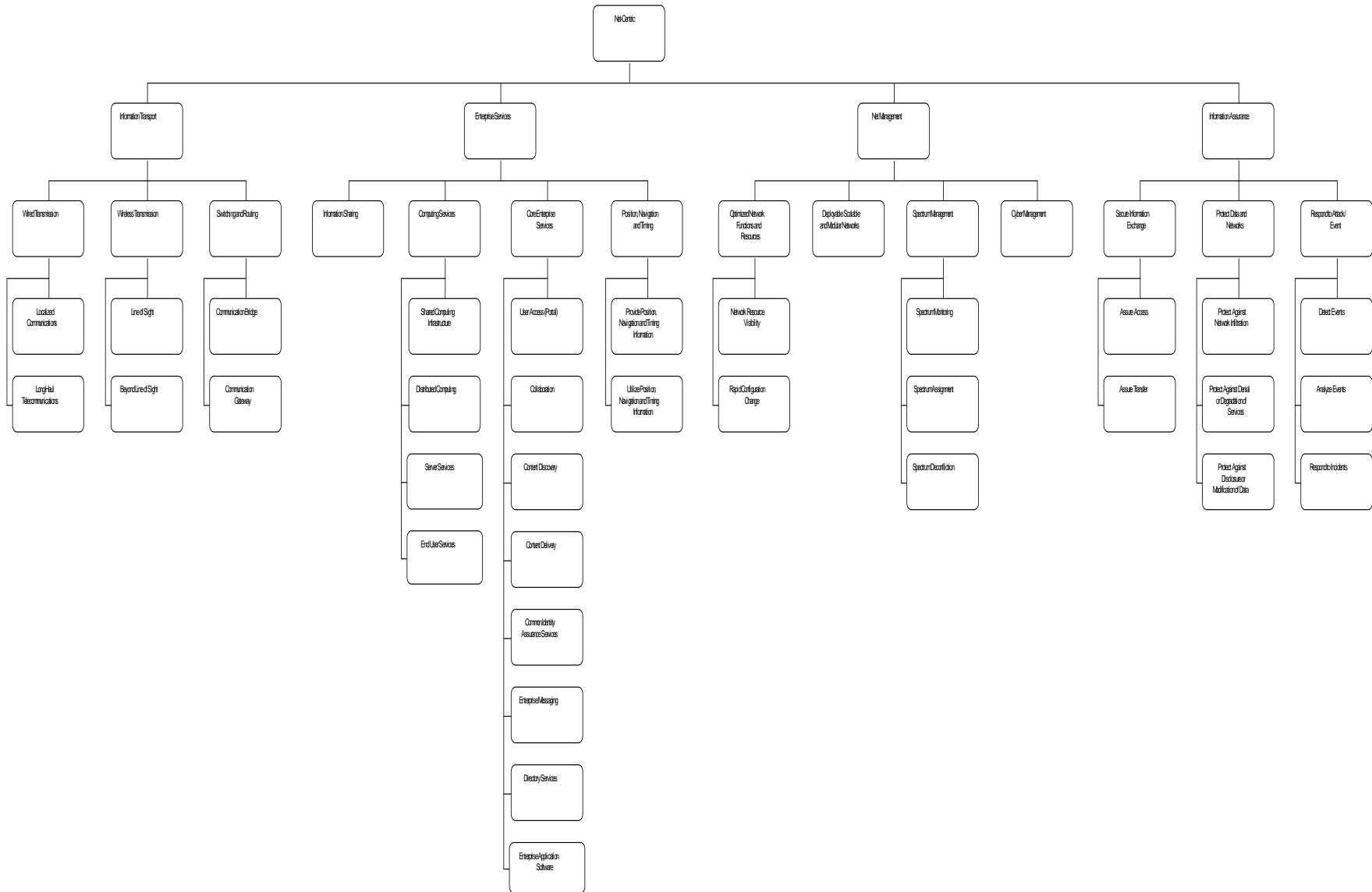

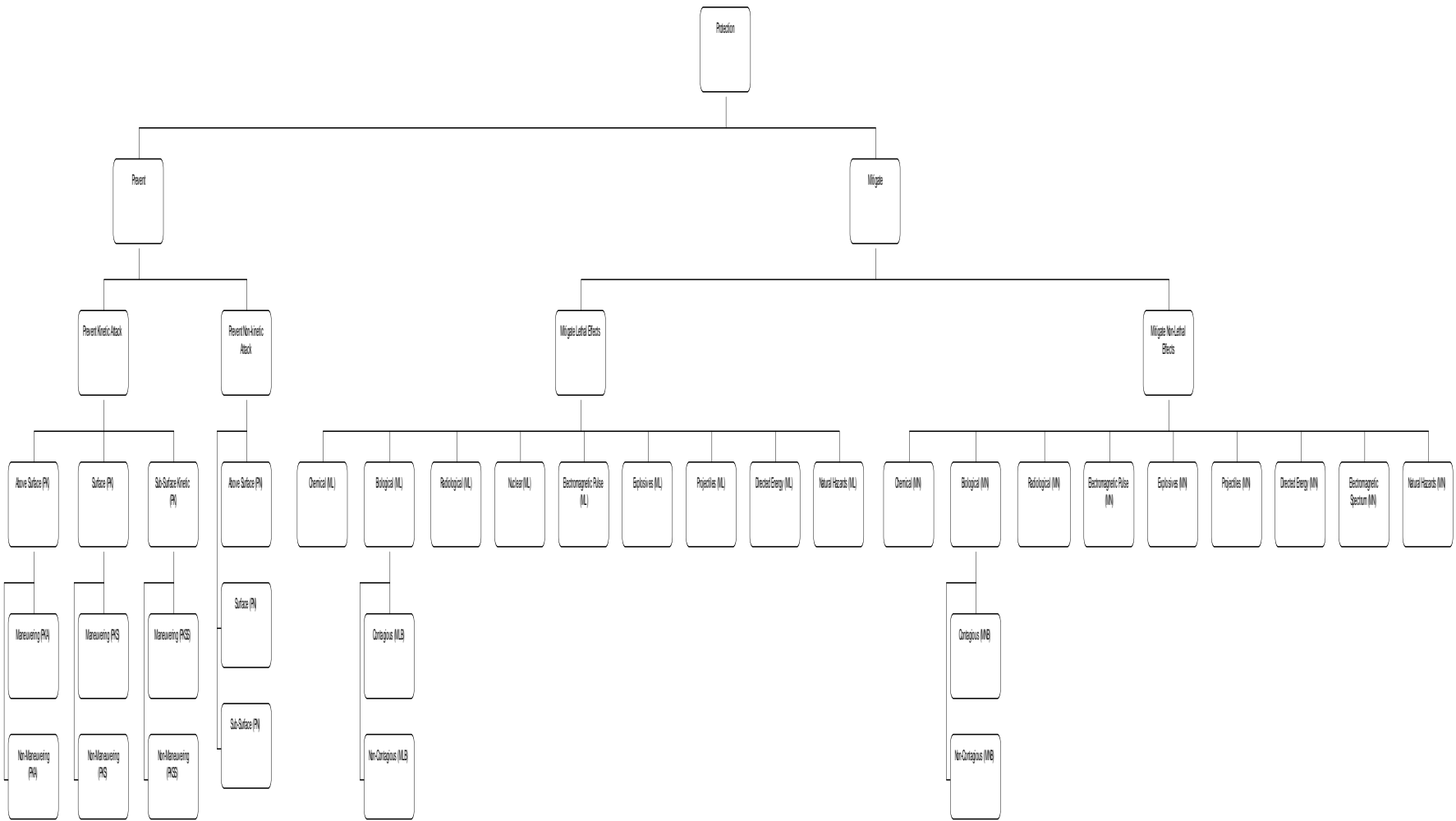

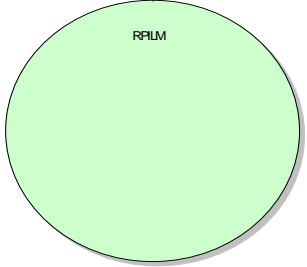
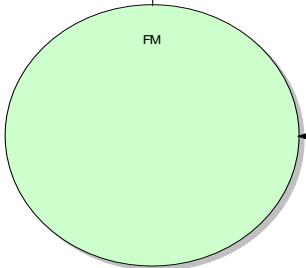
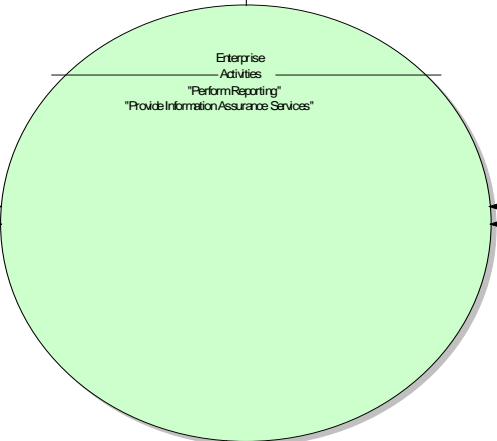
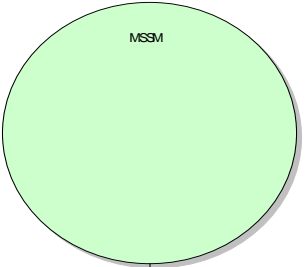
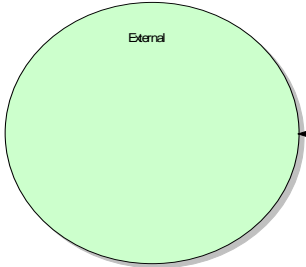

Enterprise - External

FM - Enterprise

MSSM - Enterprise
RPLM - Enterprise

Enterprise - Enterprise

Enterprise - FM

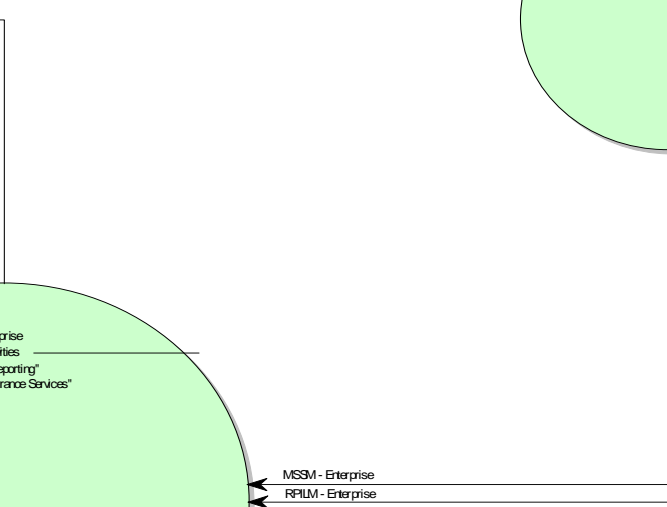
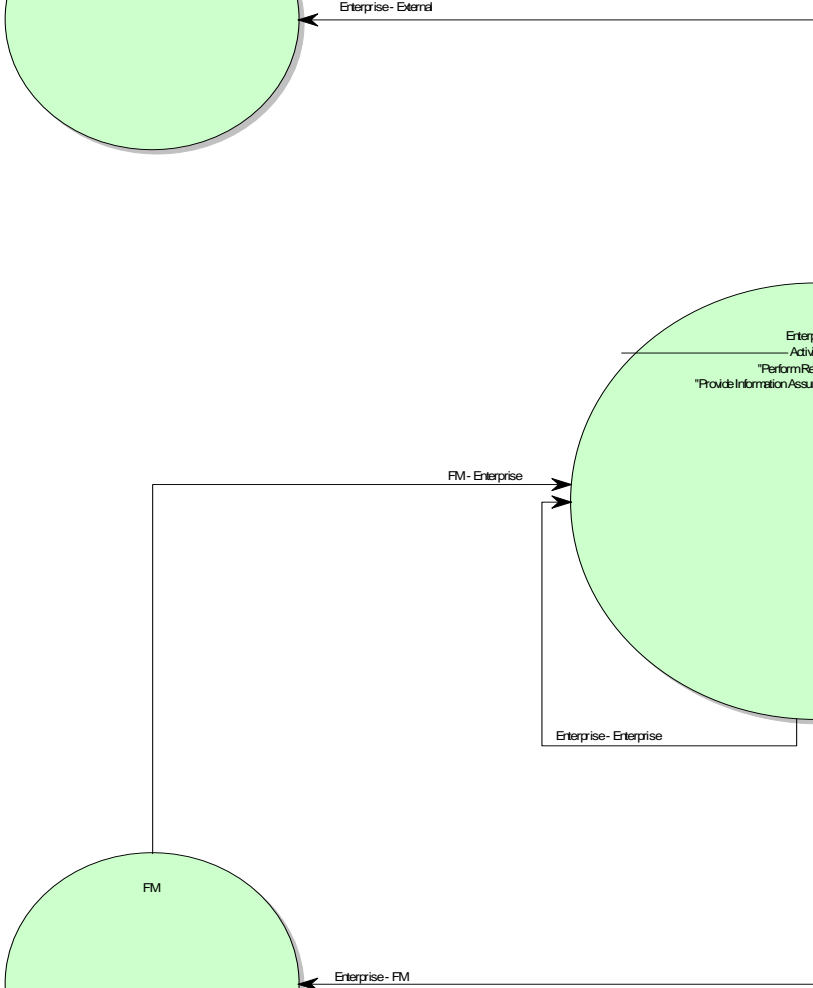

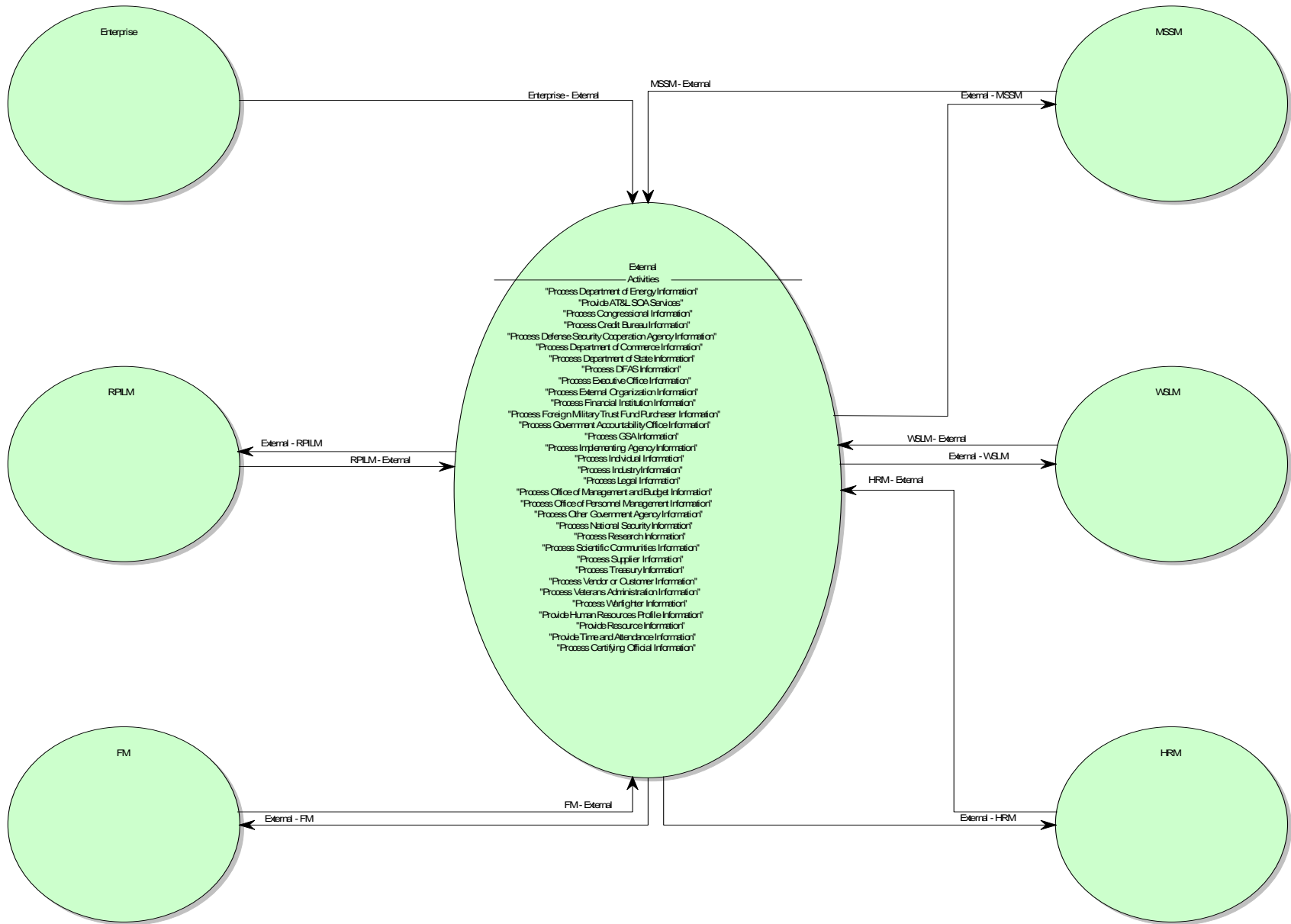

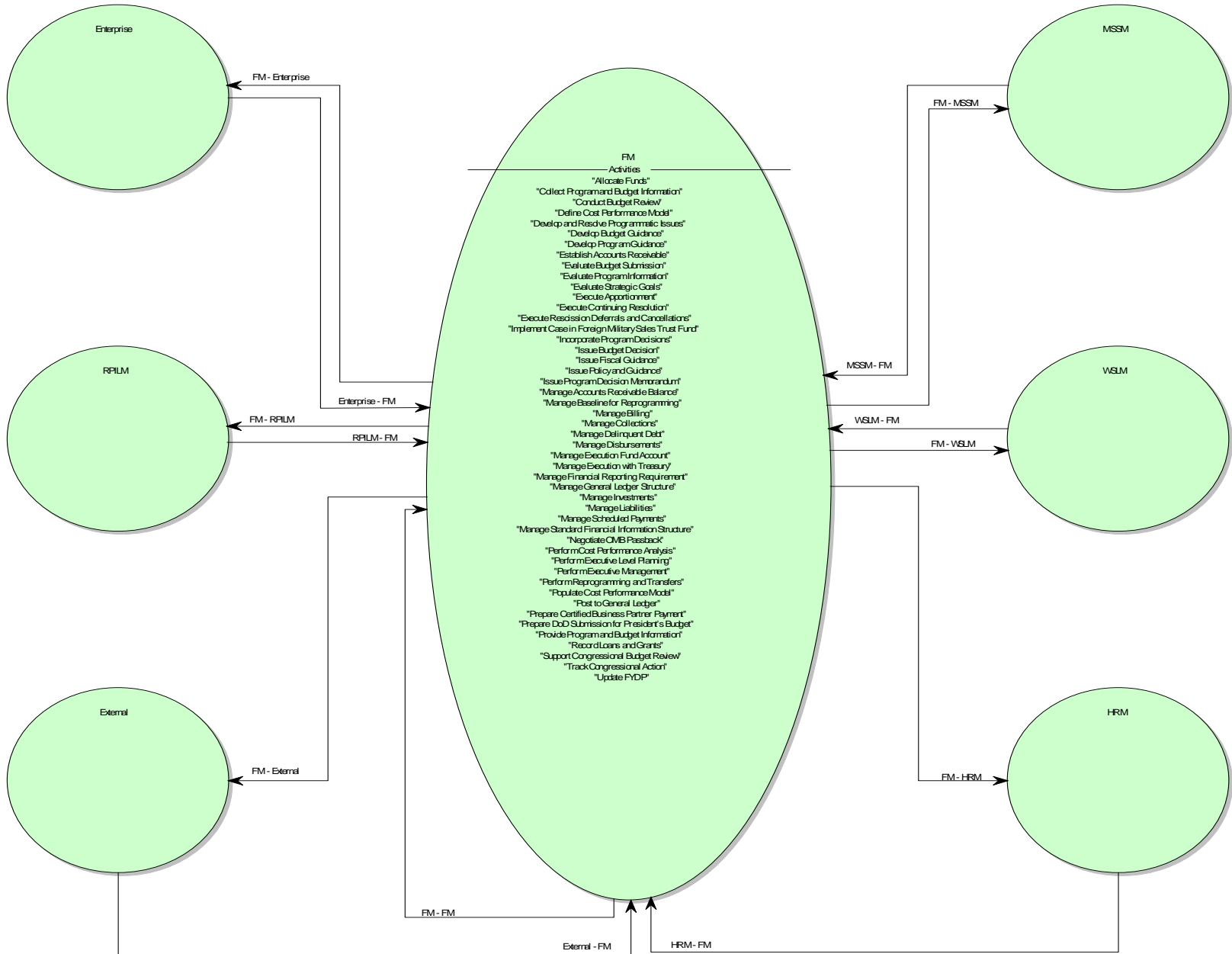

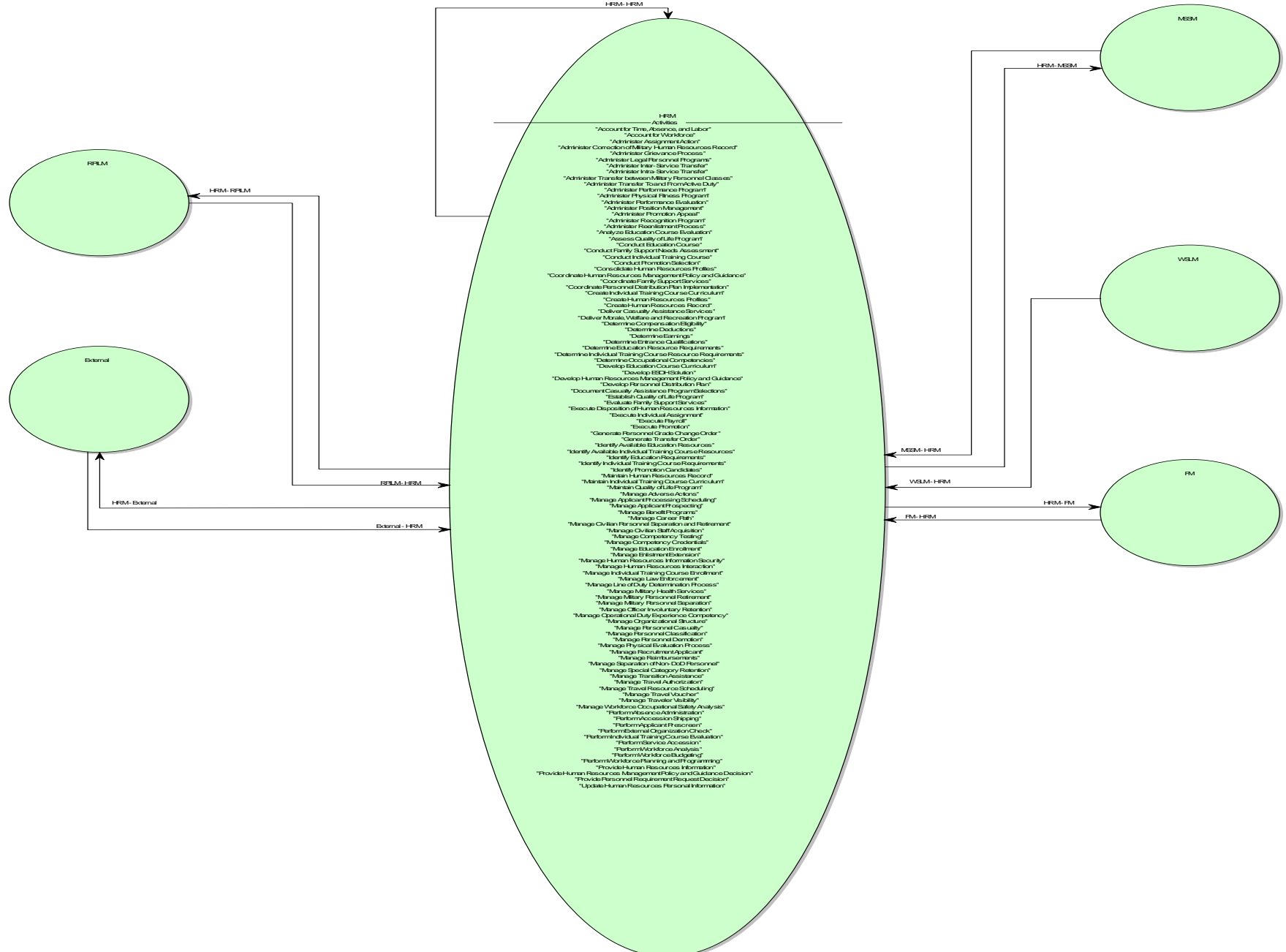

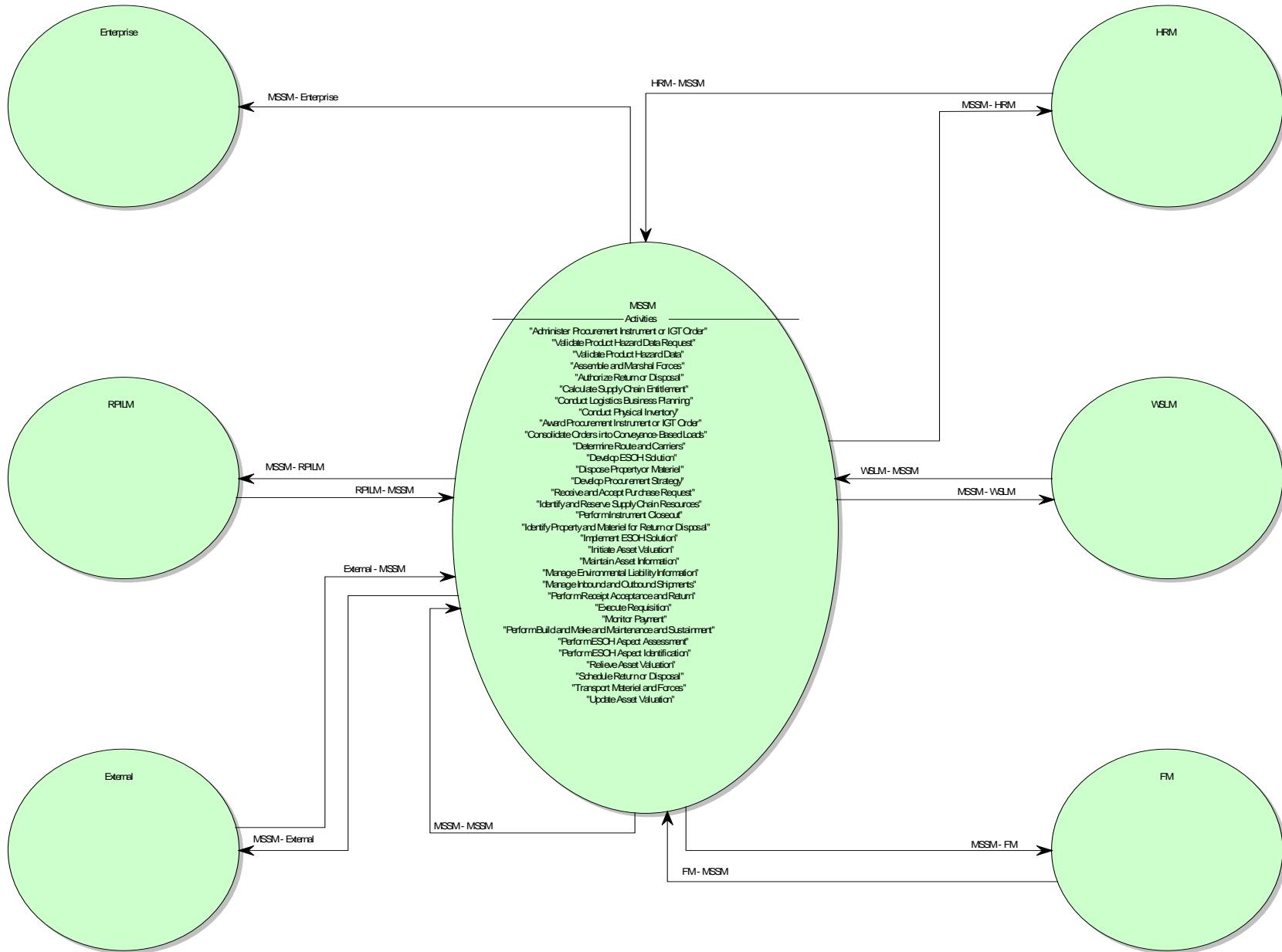

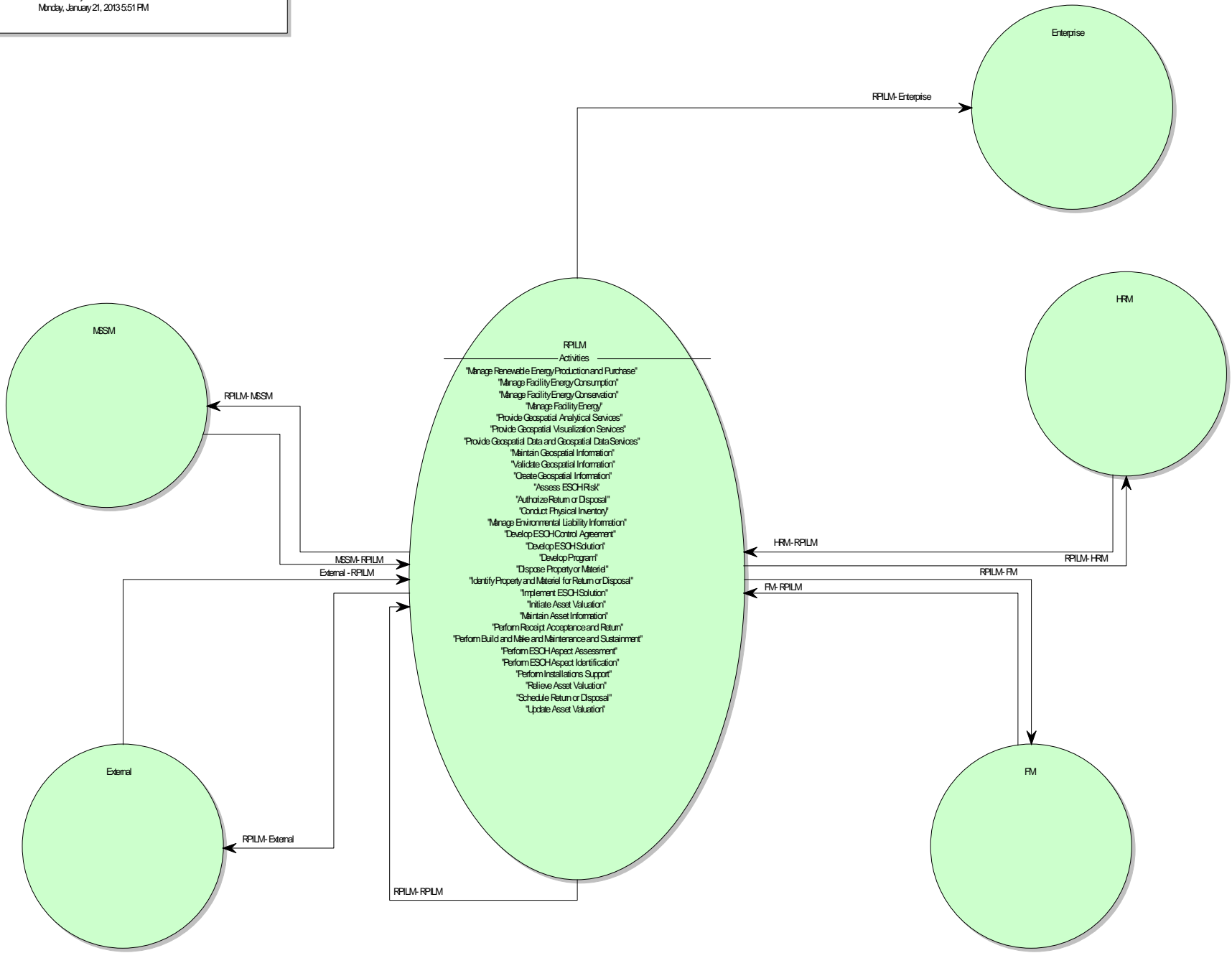

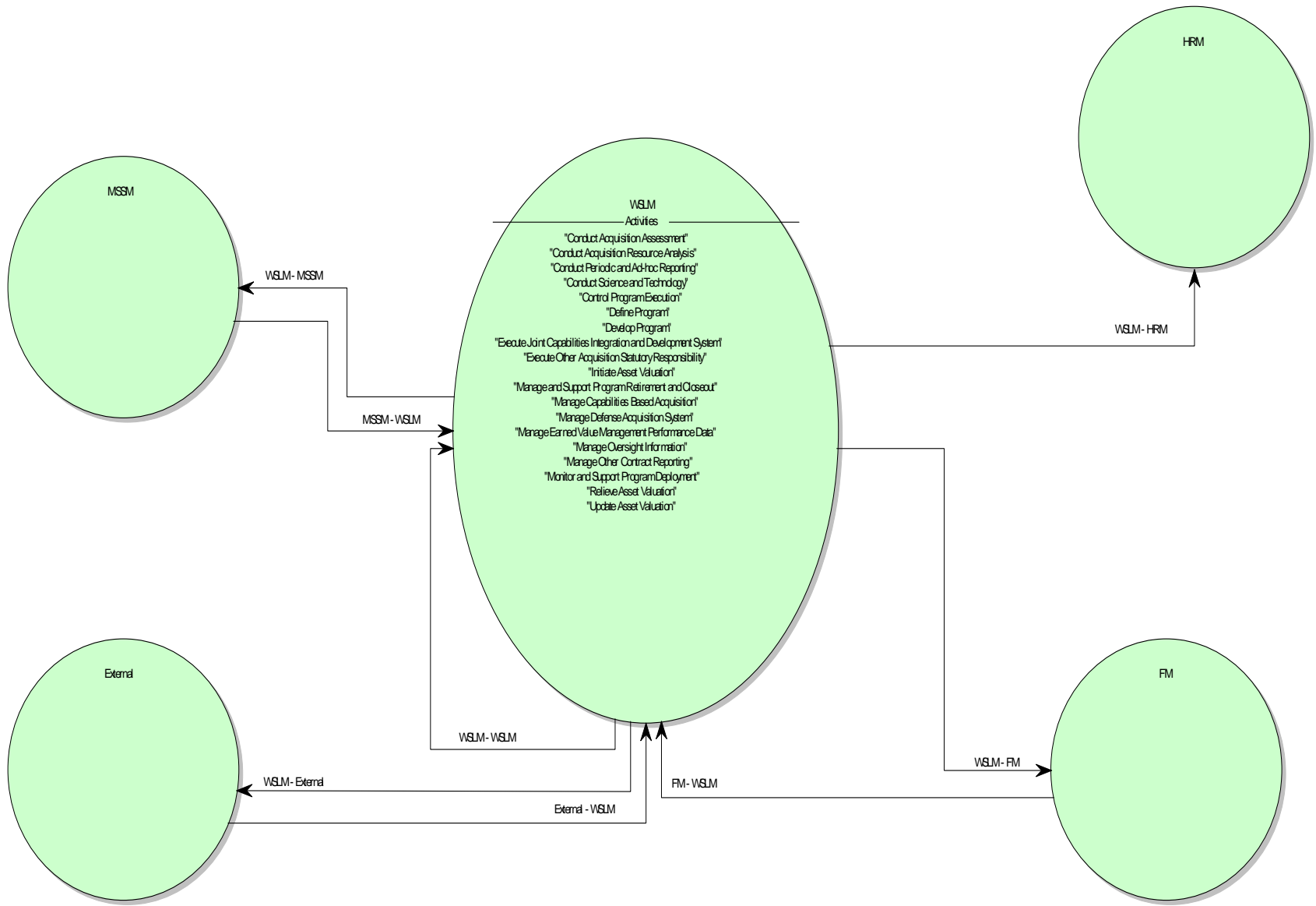

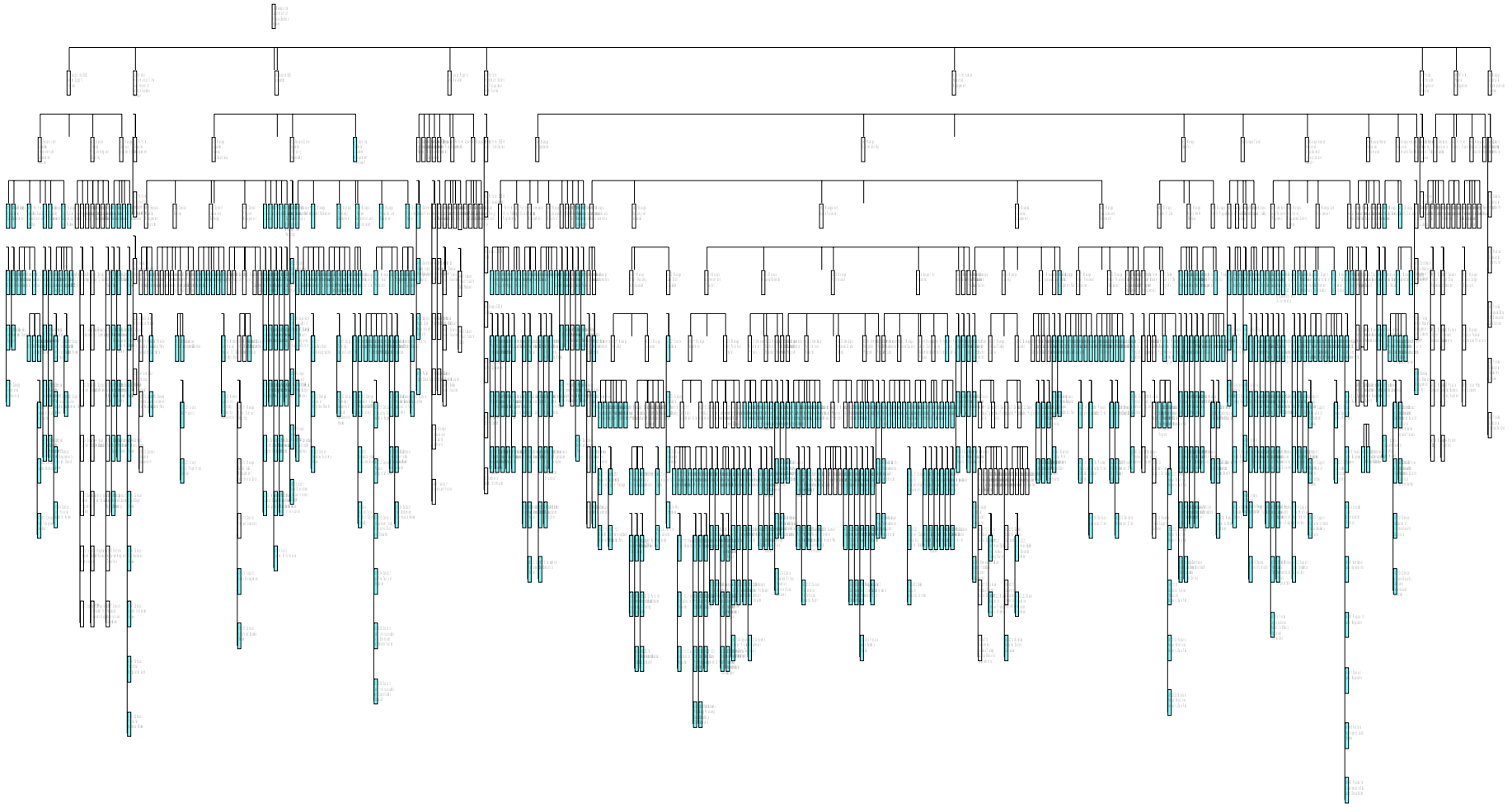

Small text label, possibly a page number or a section identifier.

Small text label, possibly a legend or a key.



Small text label at the bottom, possibly a footer or a note.

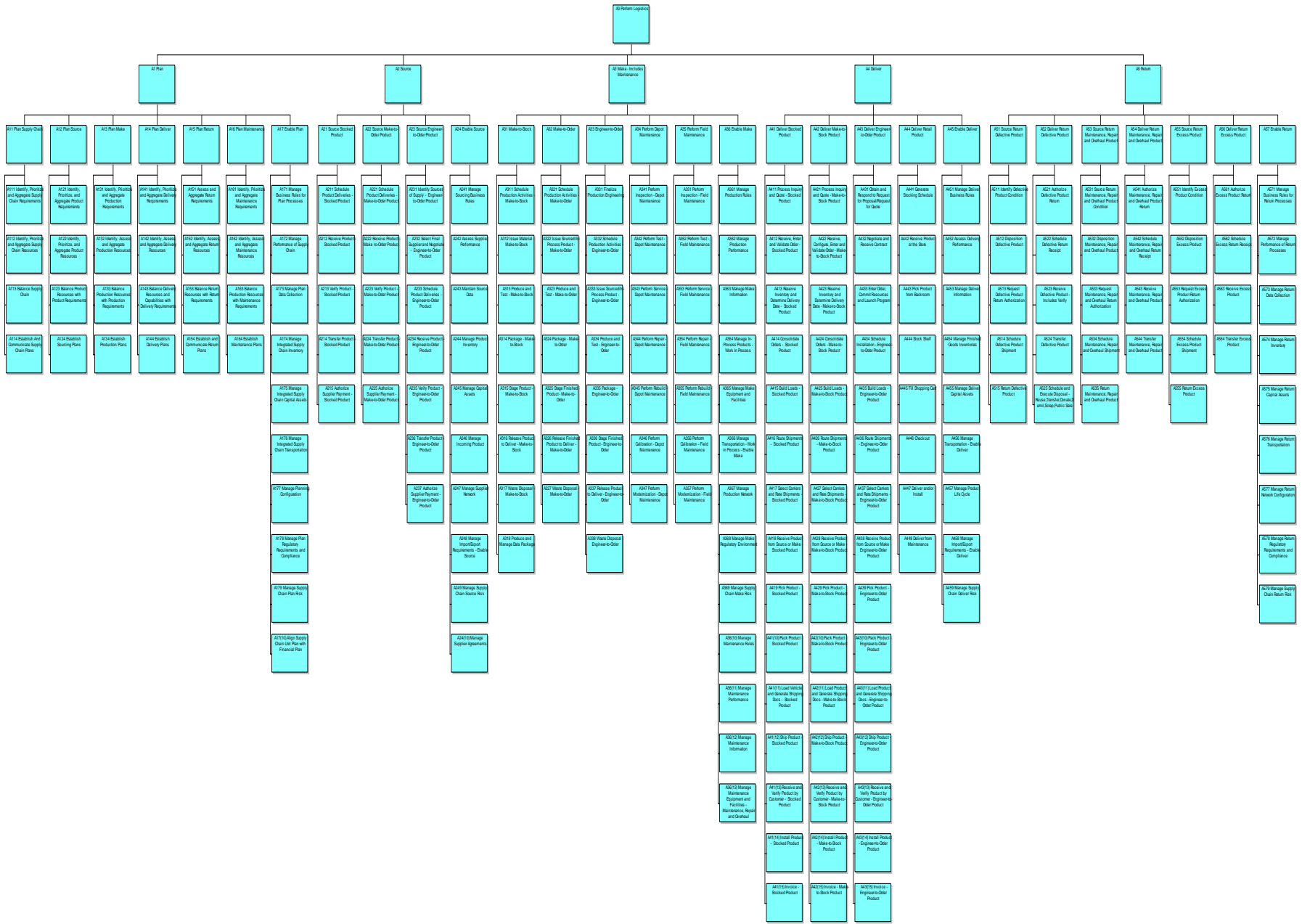

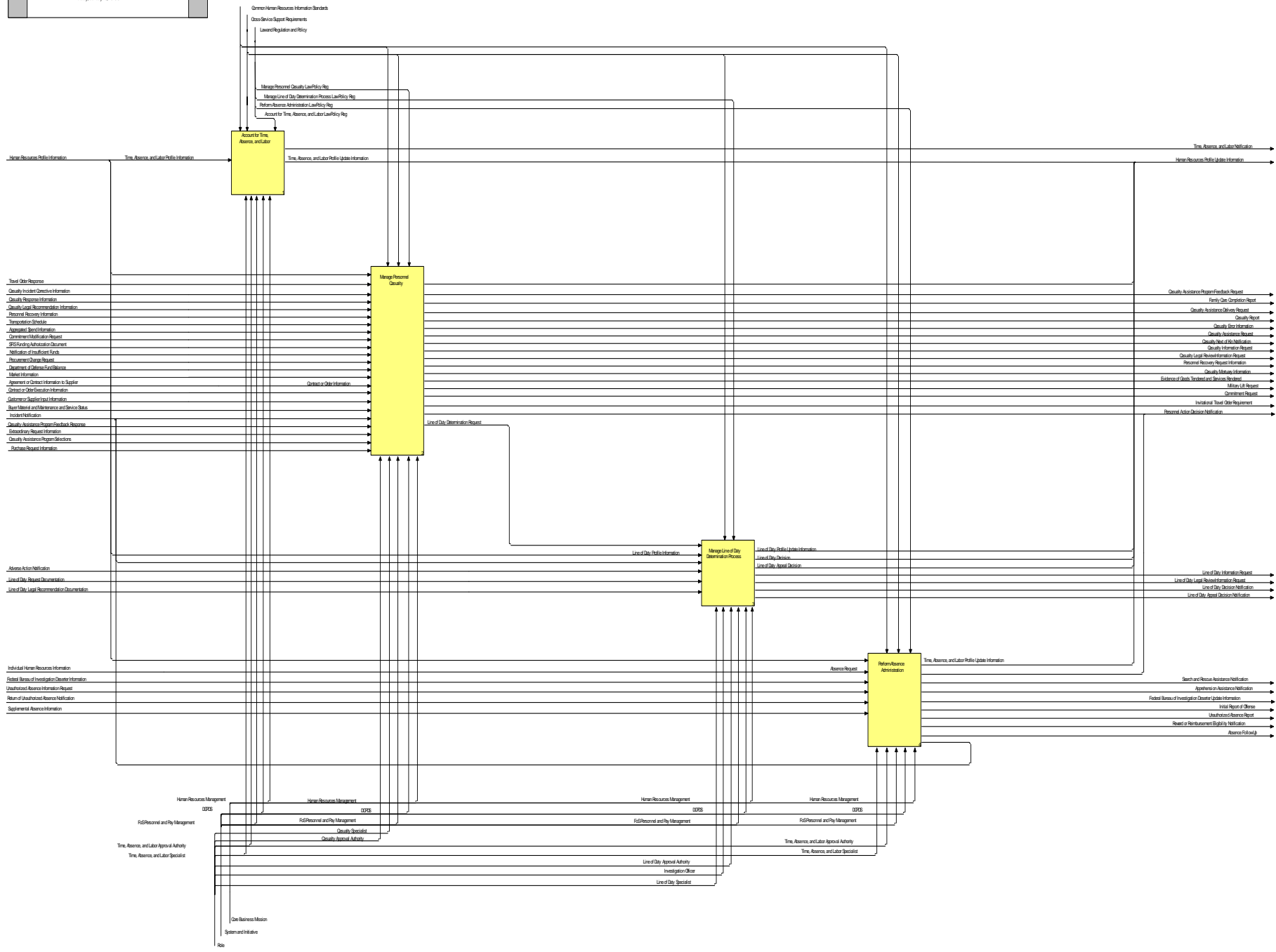

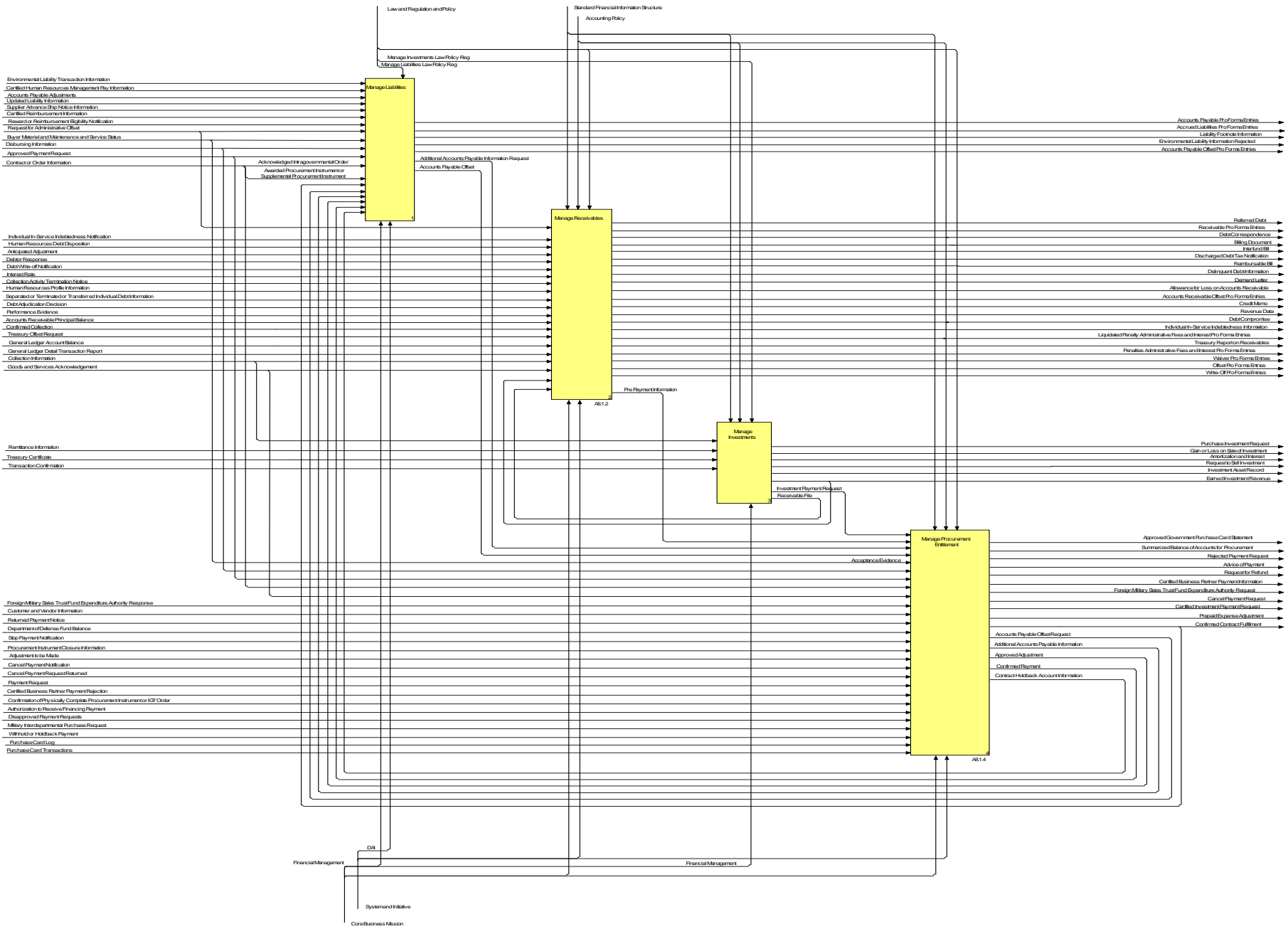

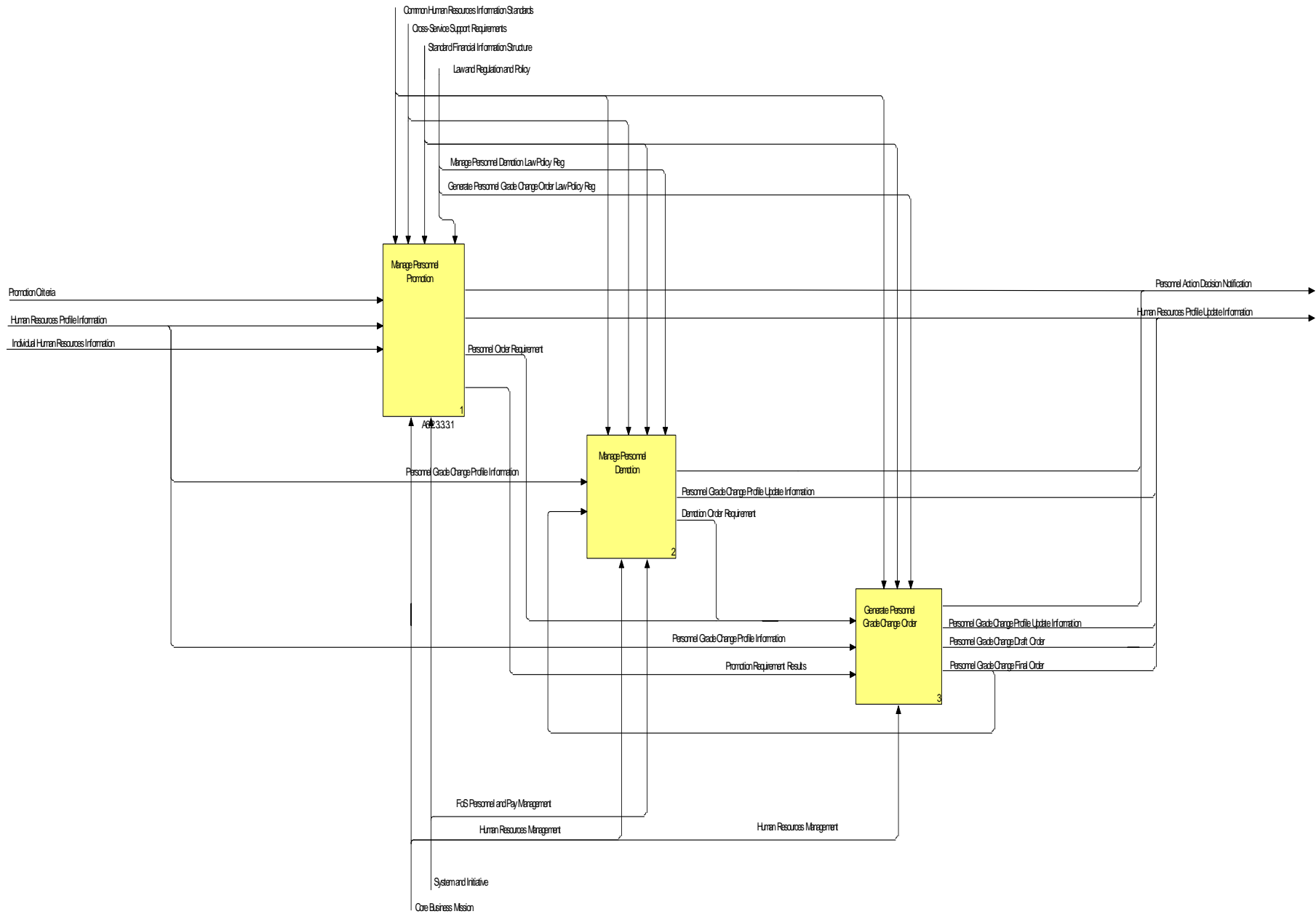

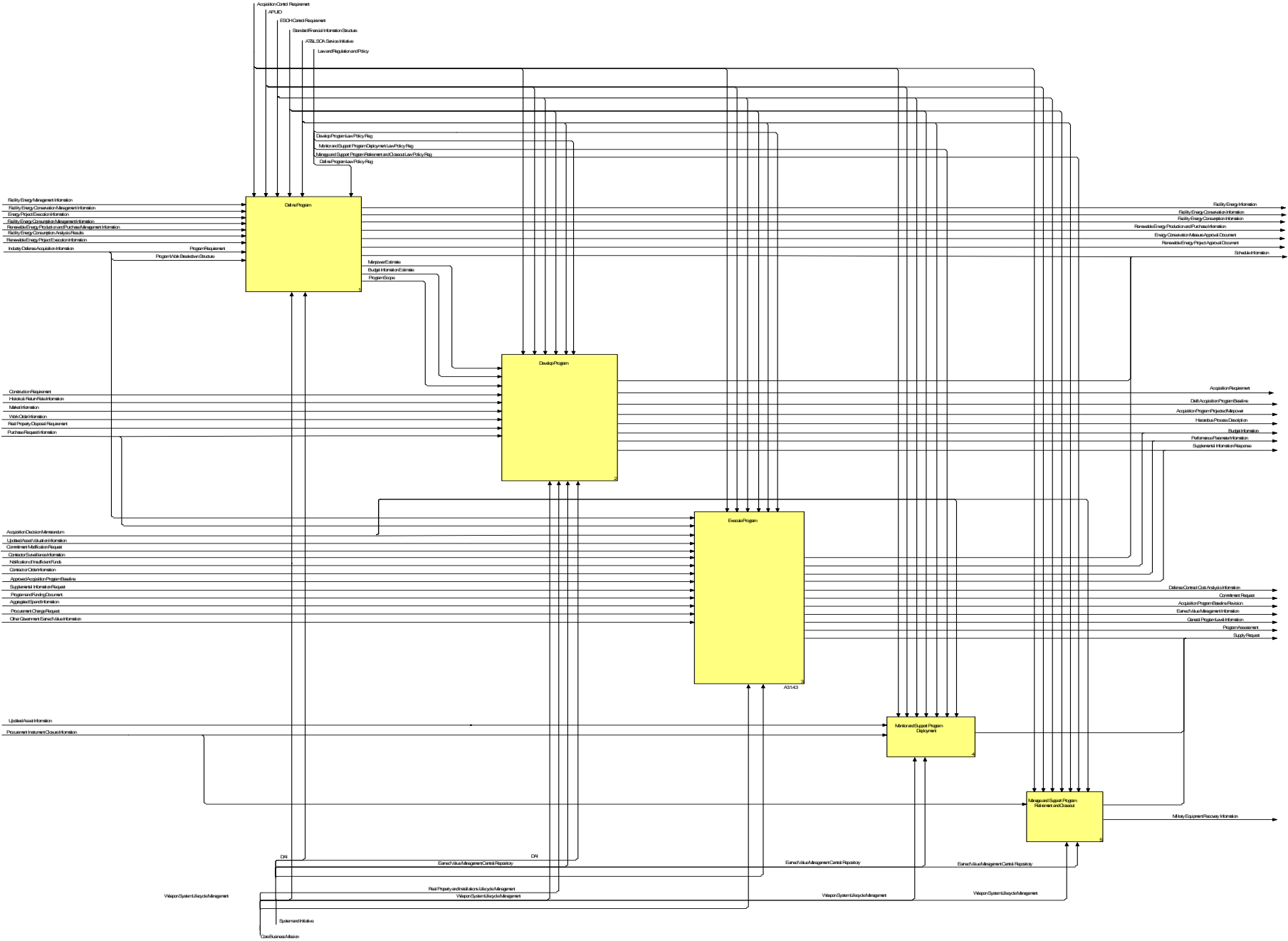

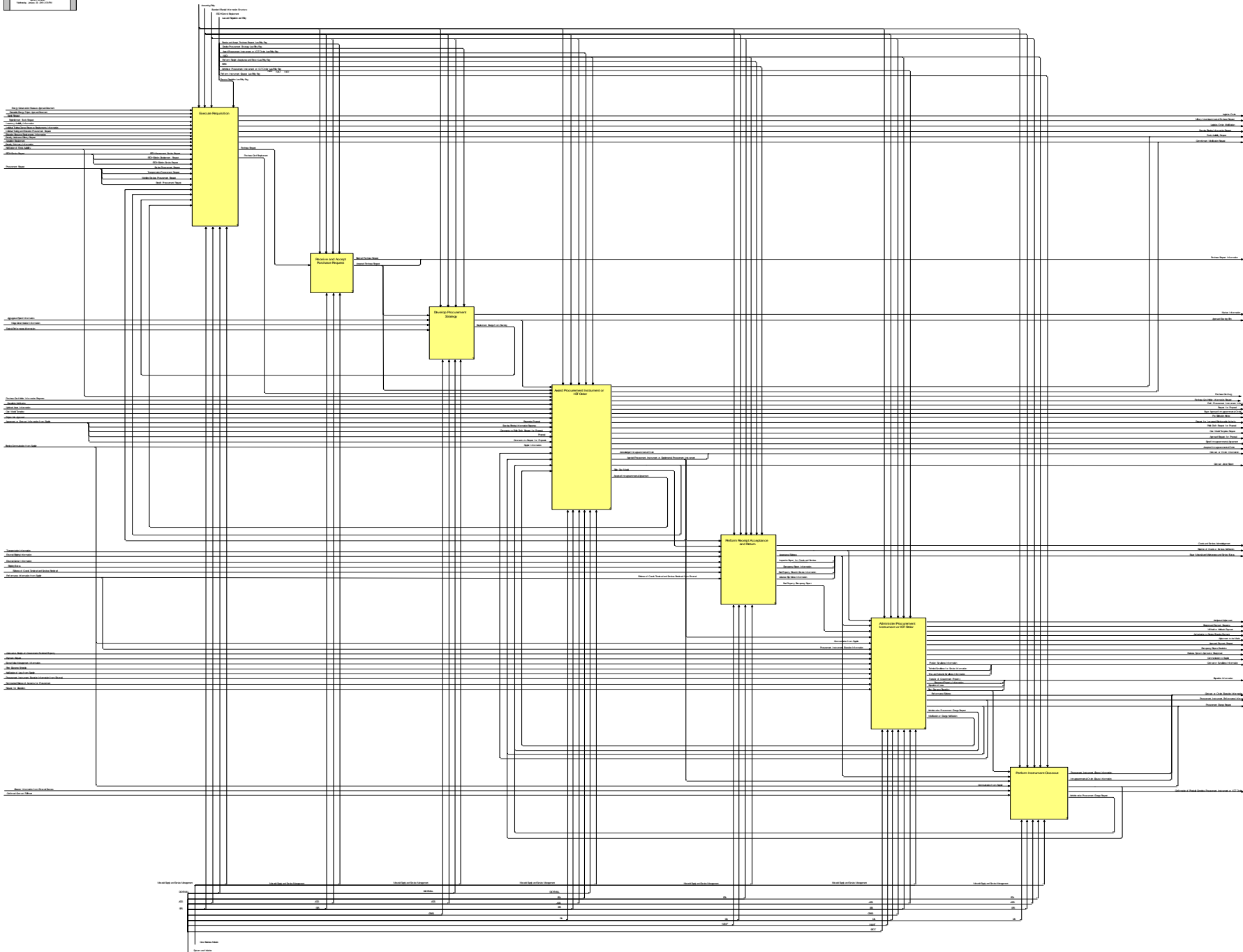

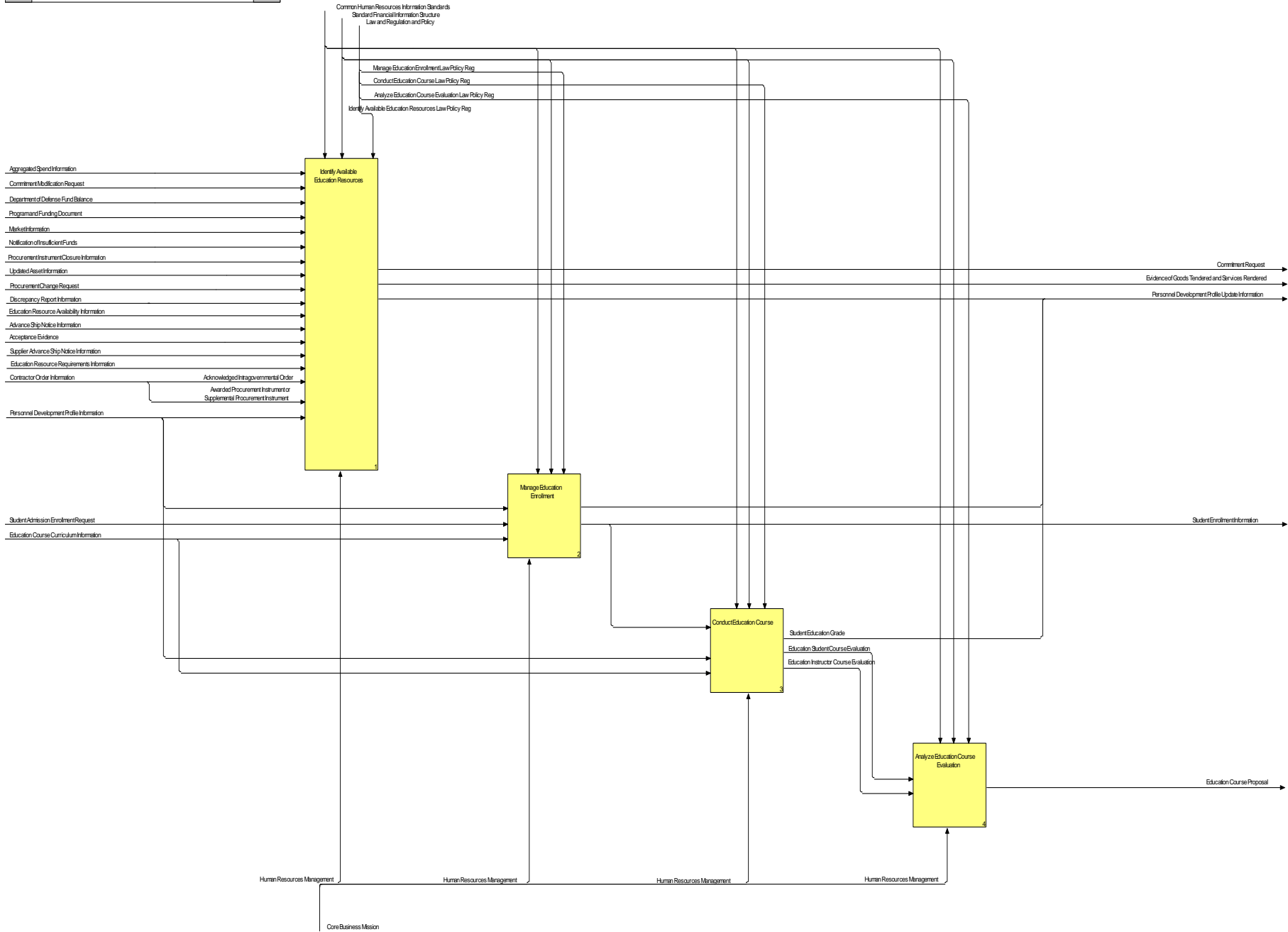

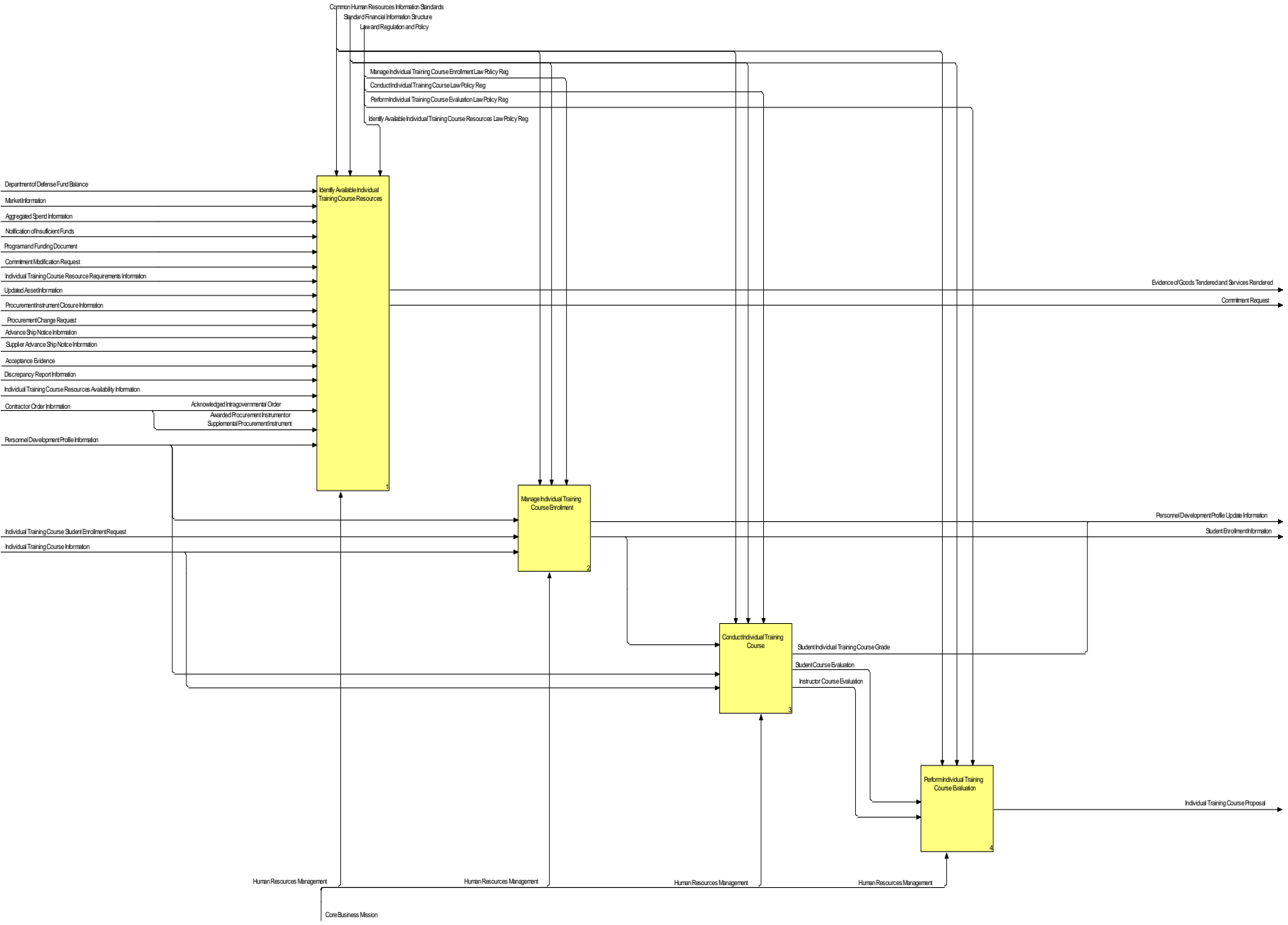

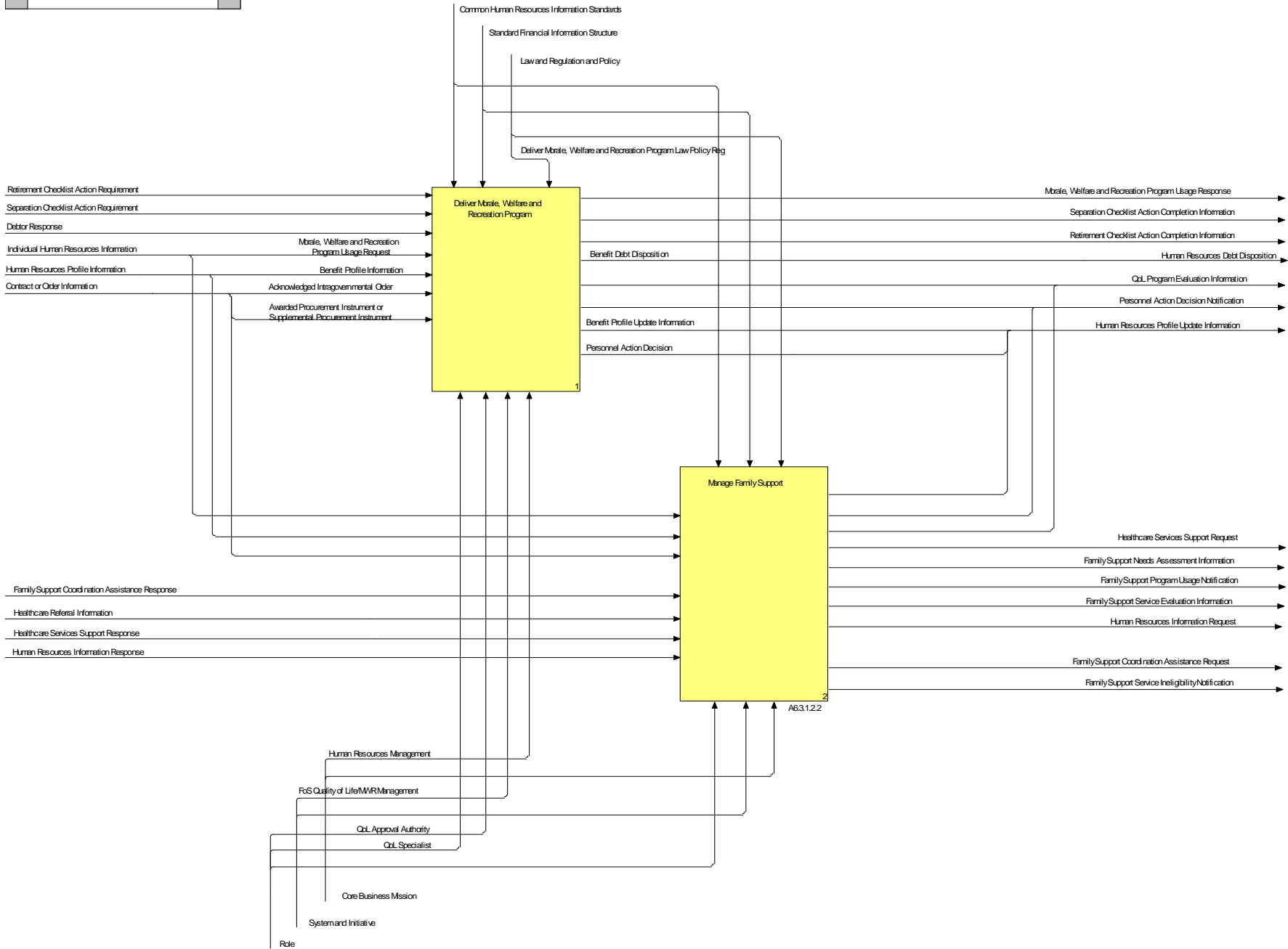

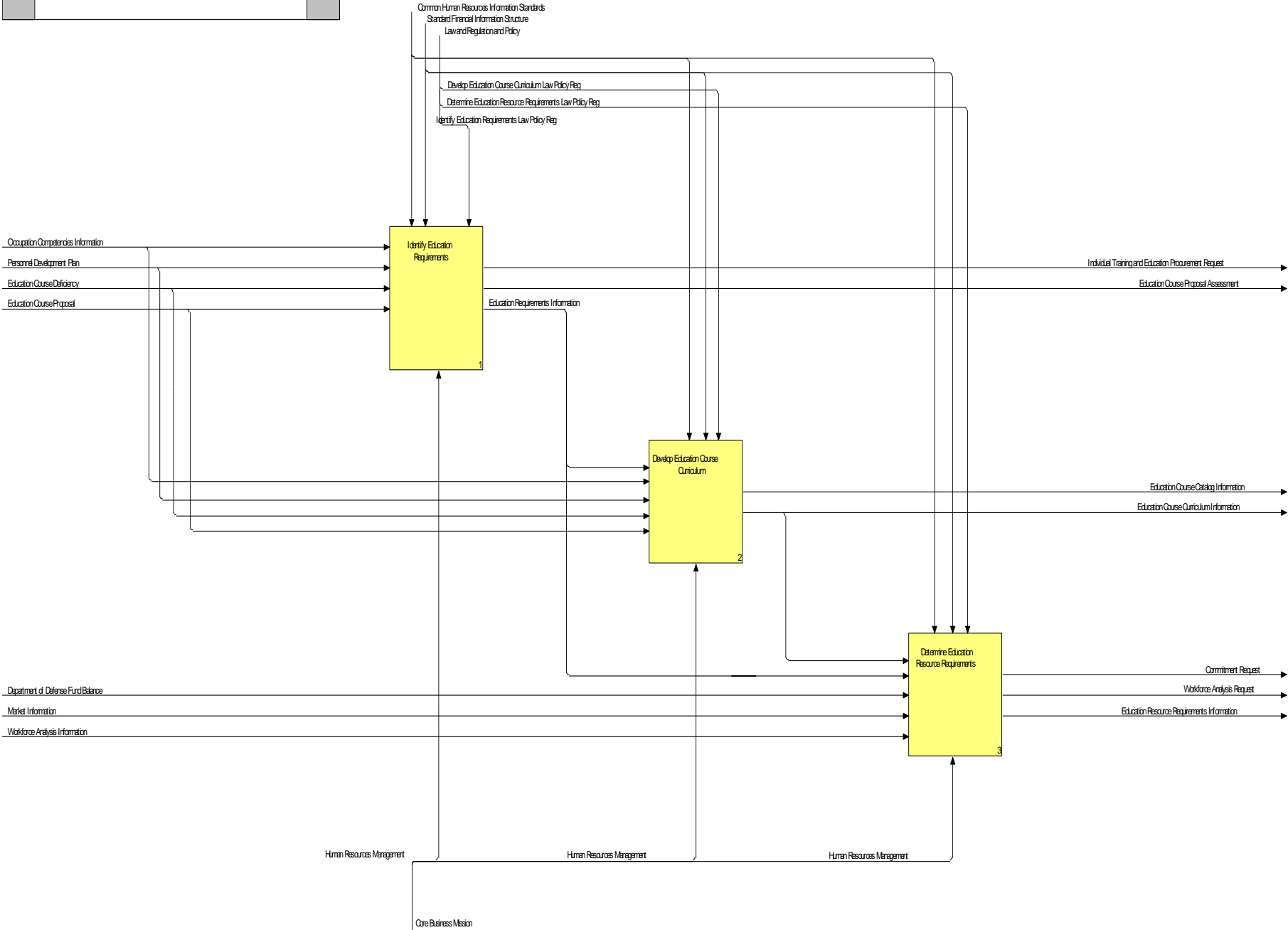

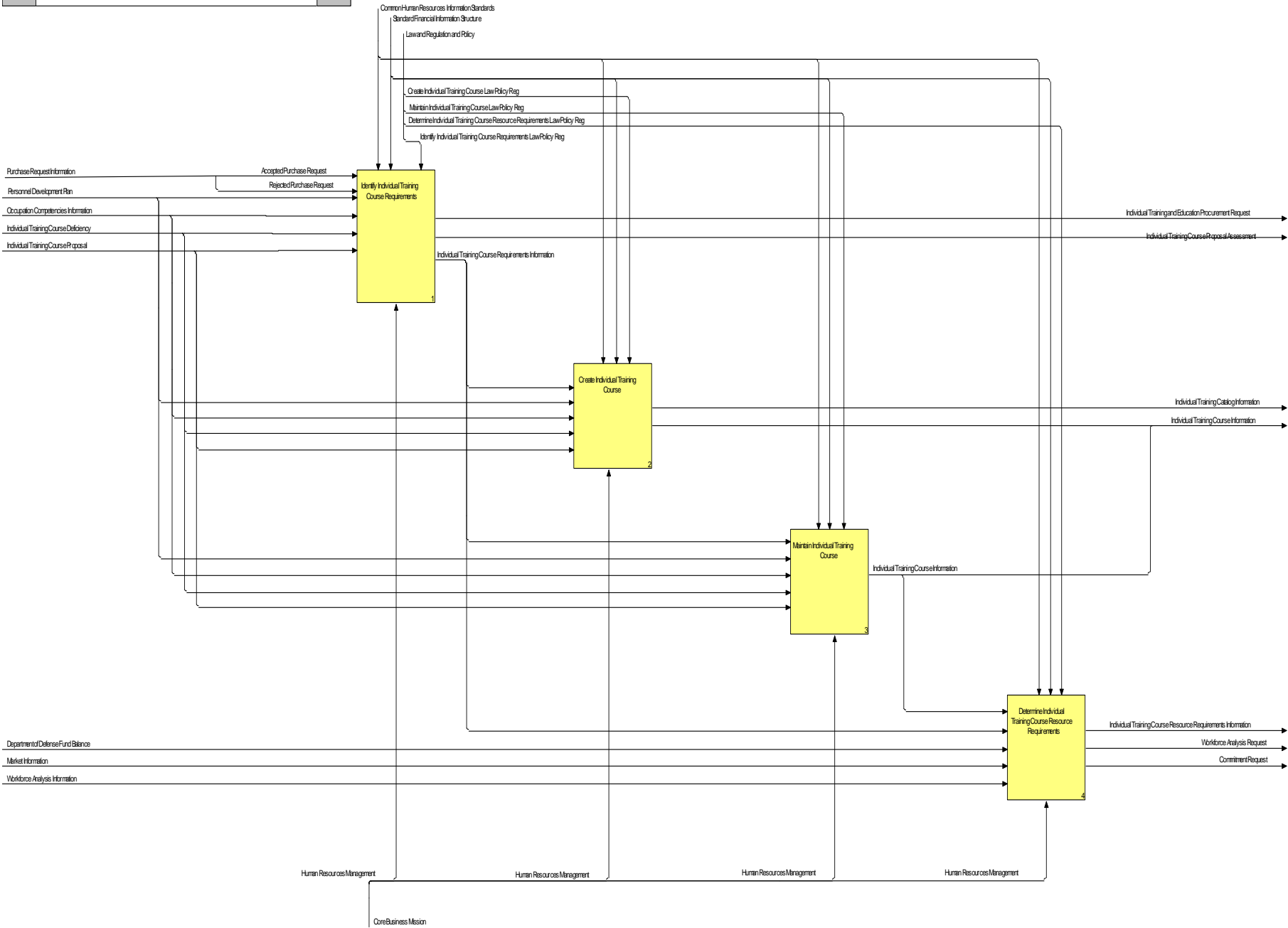

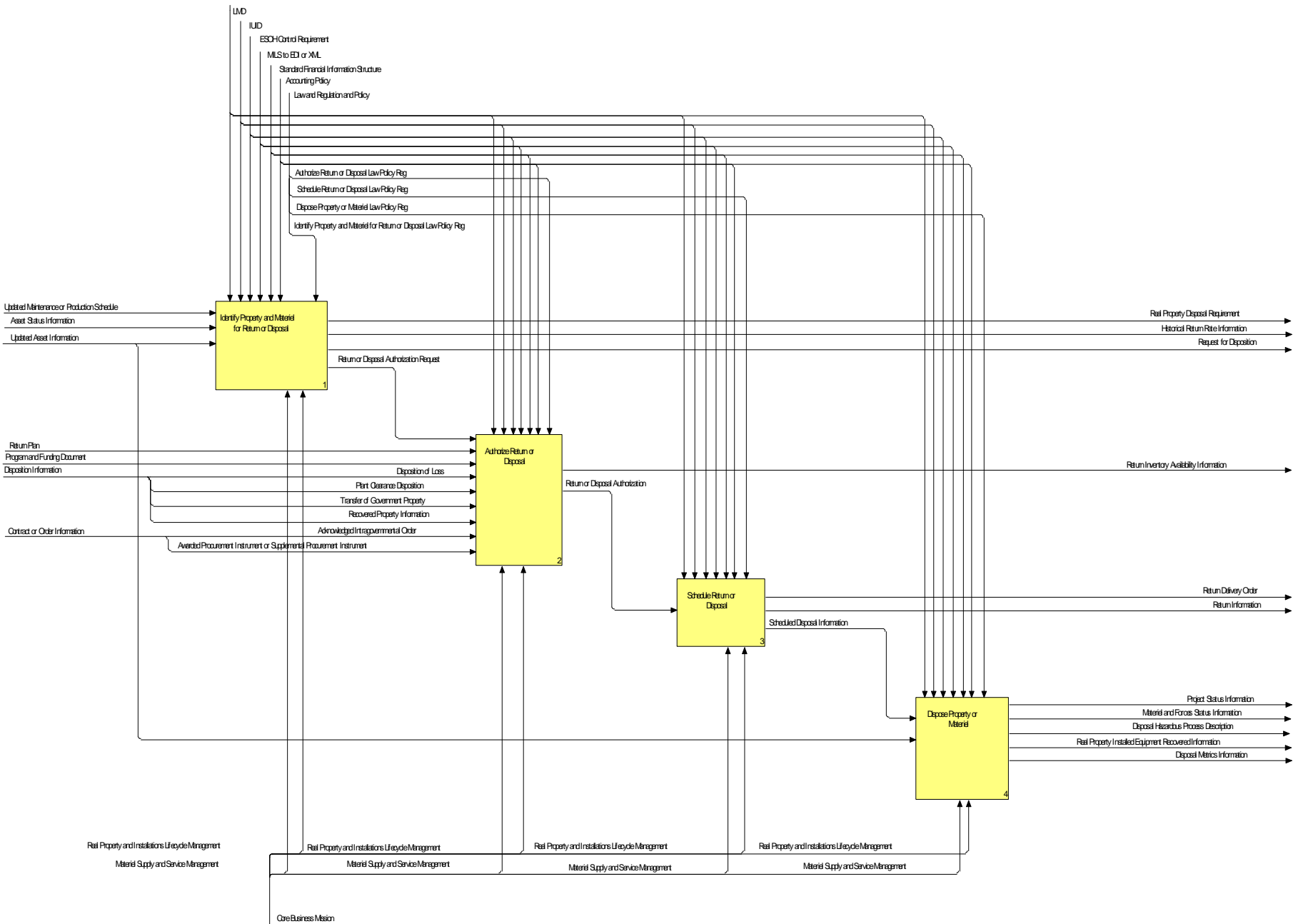

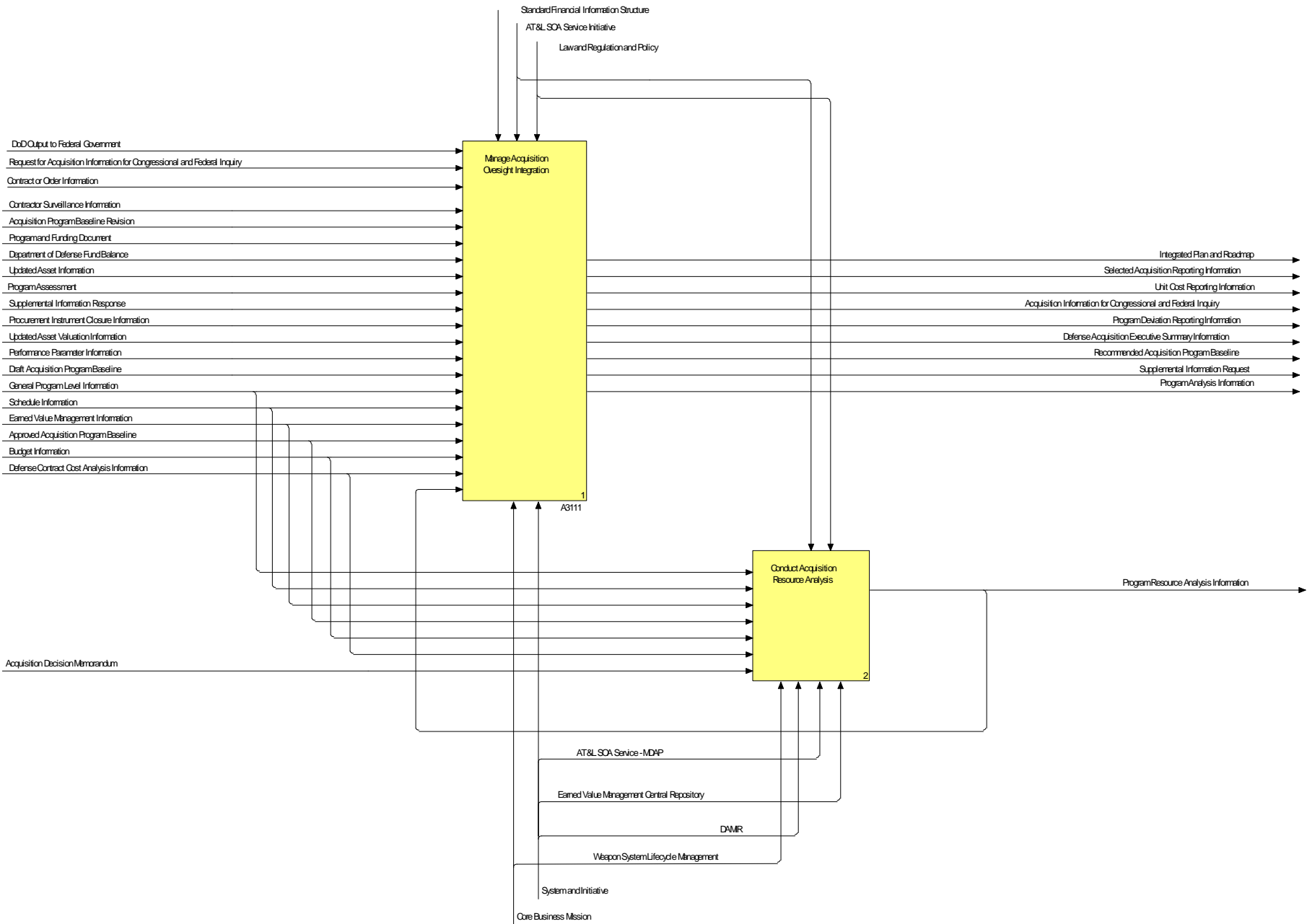

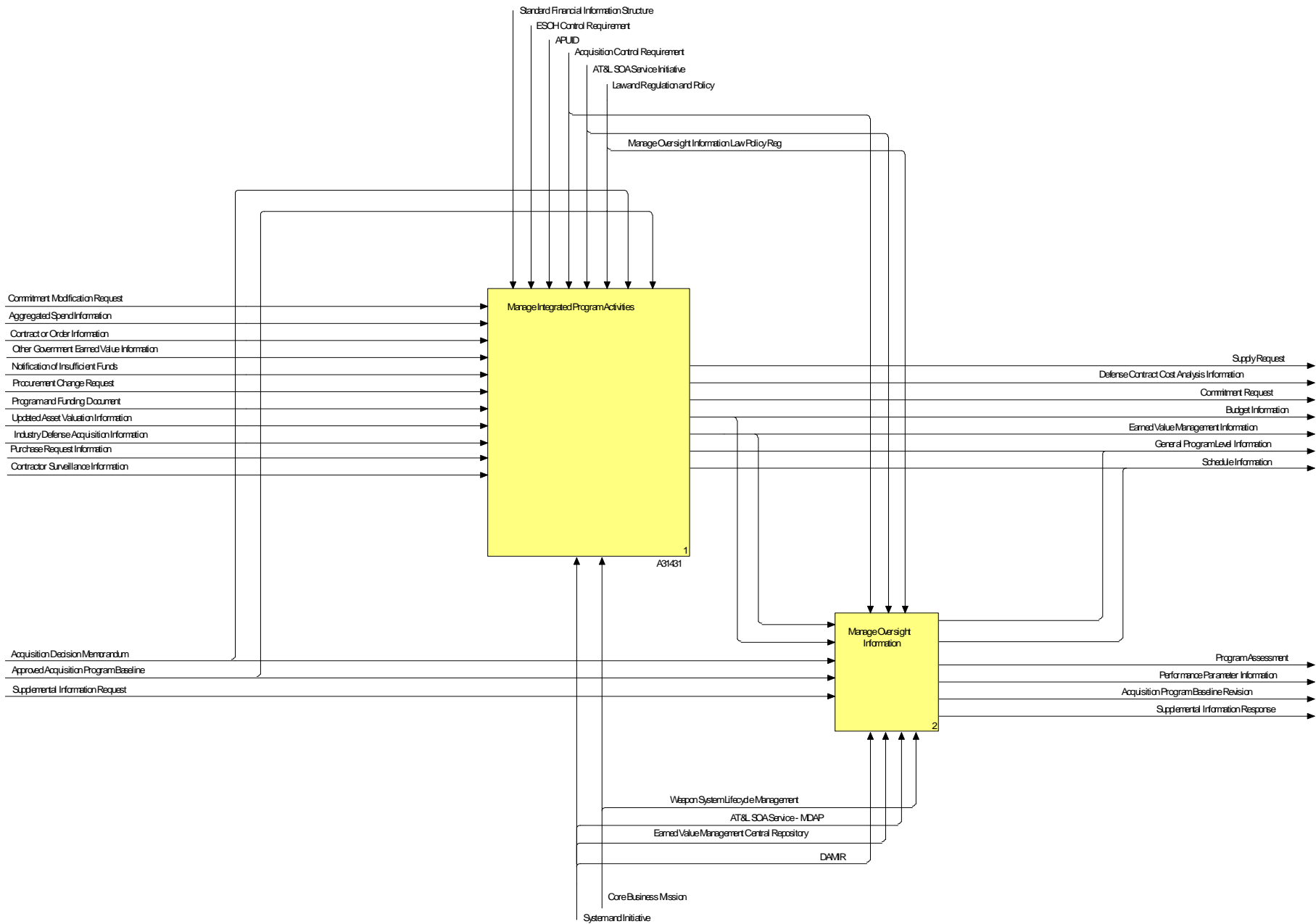

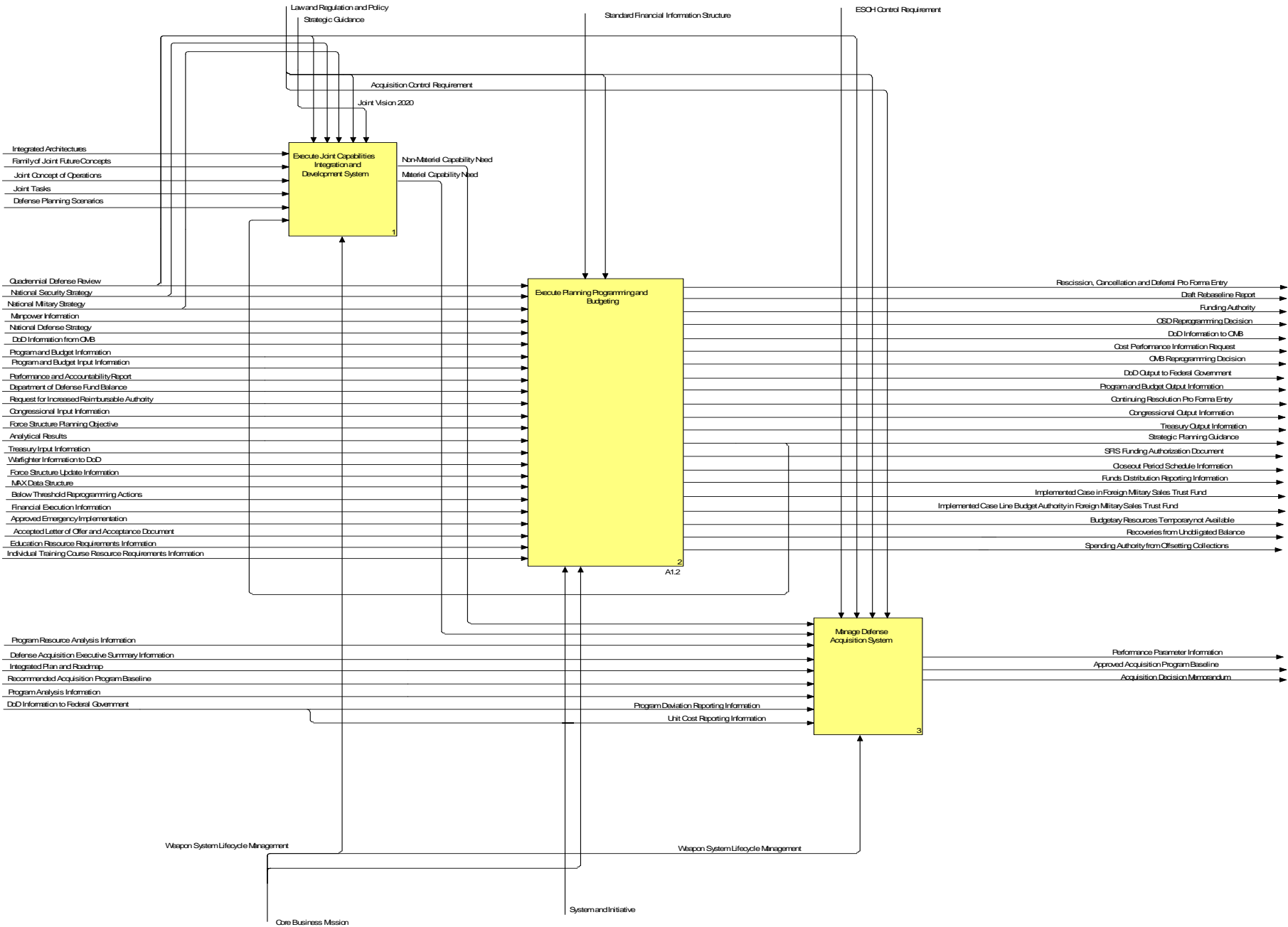

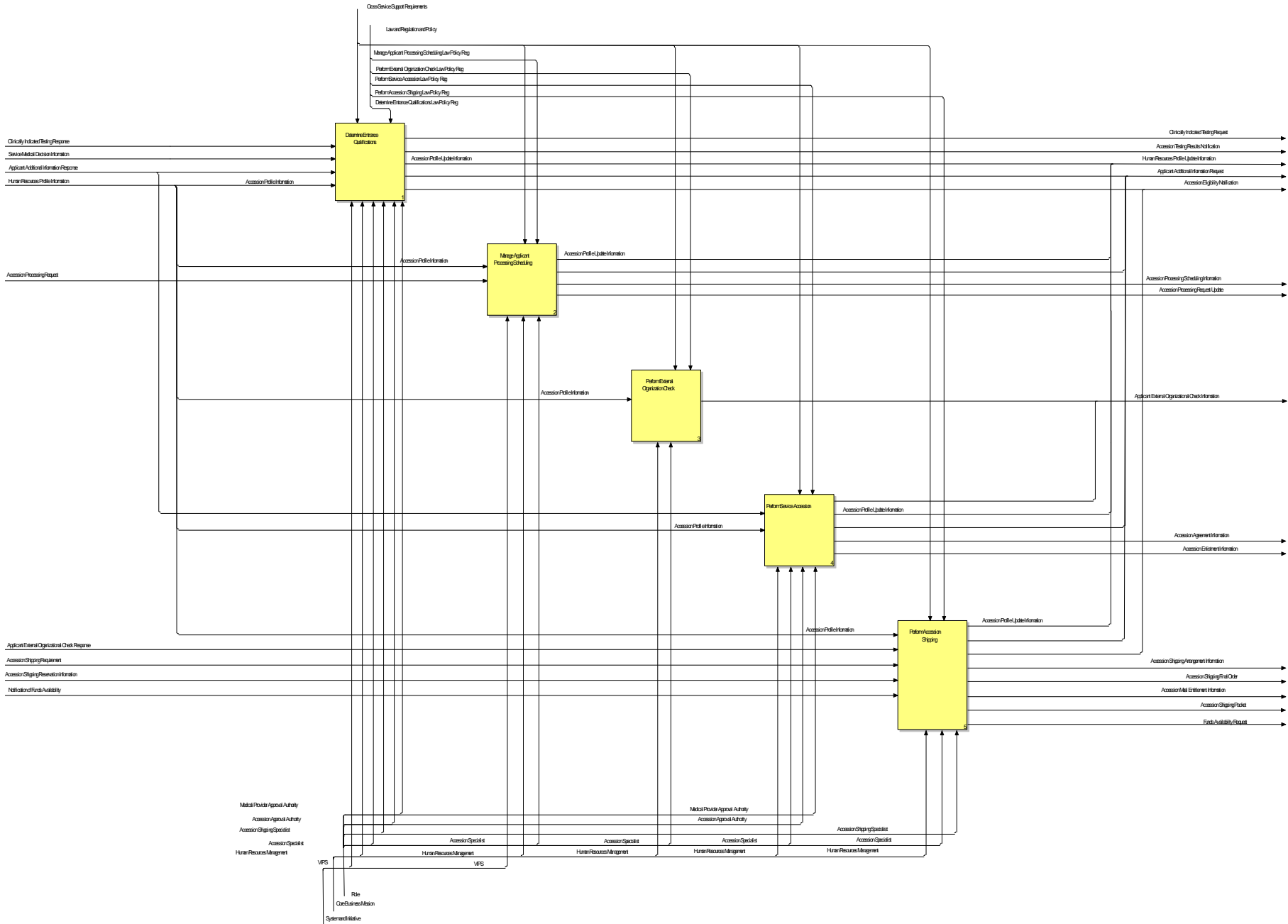

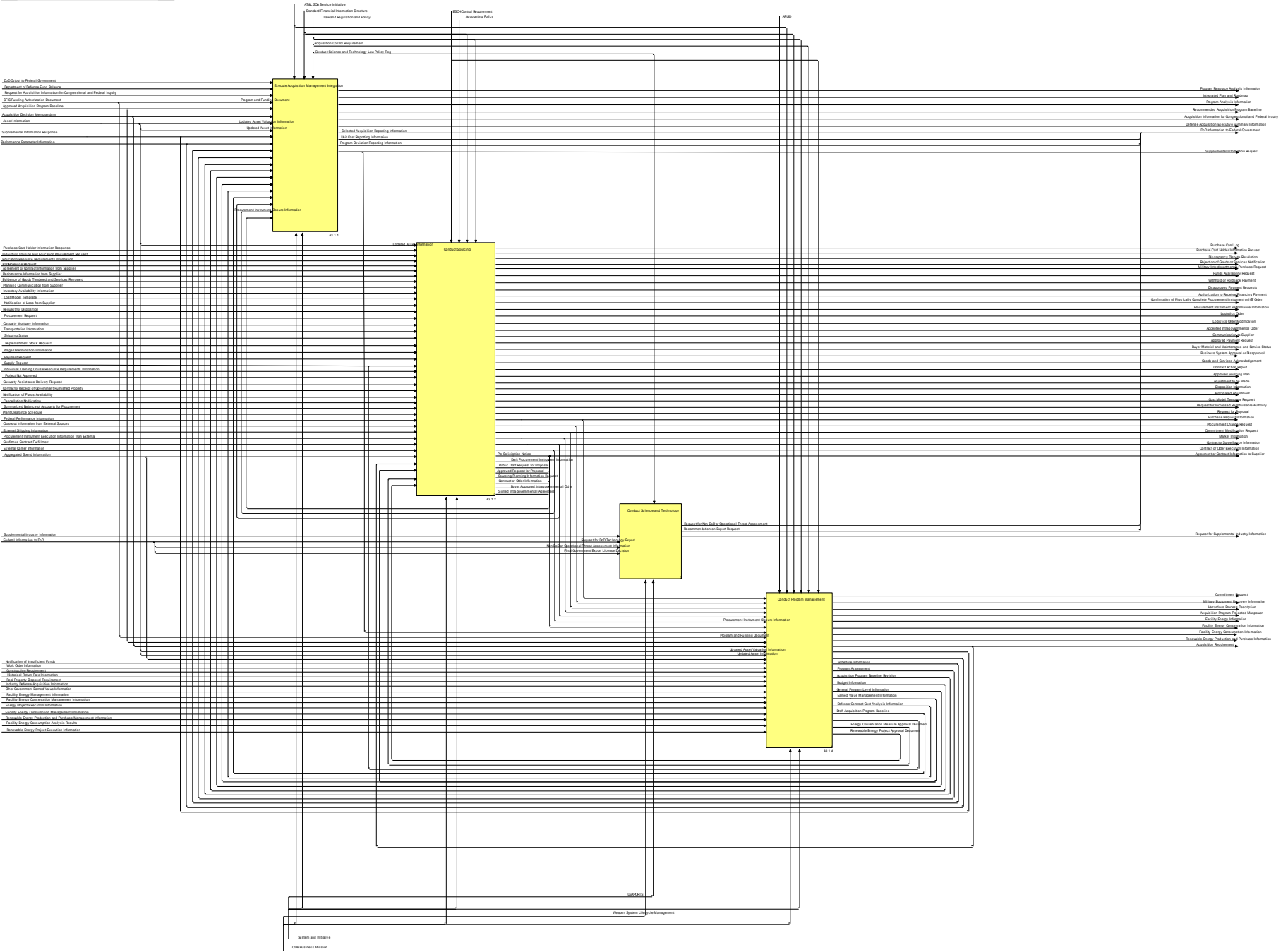

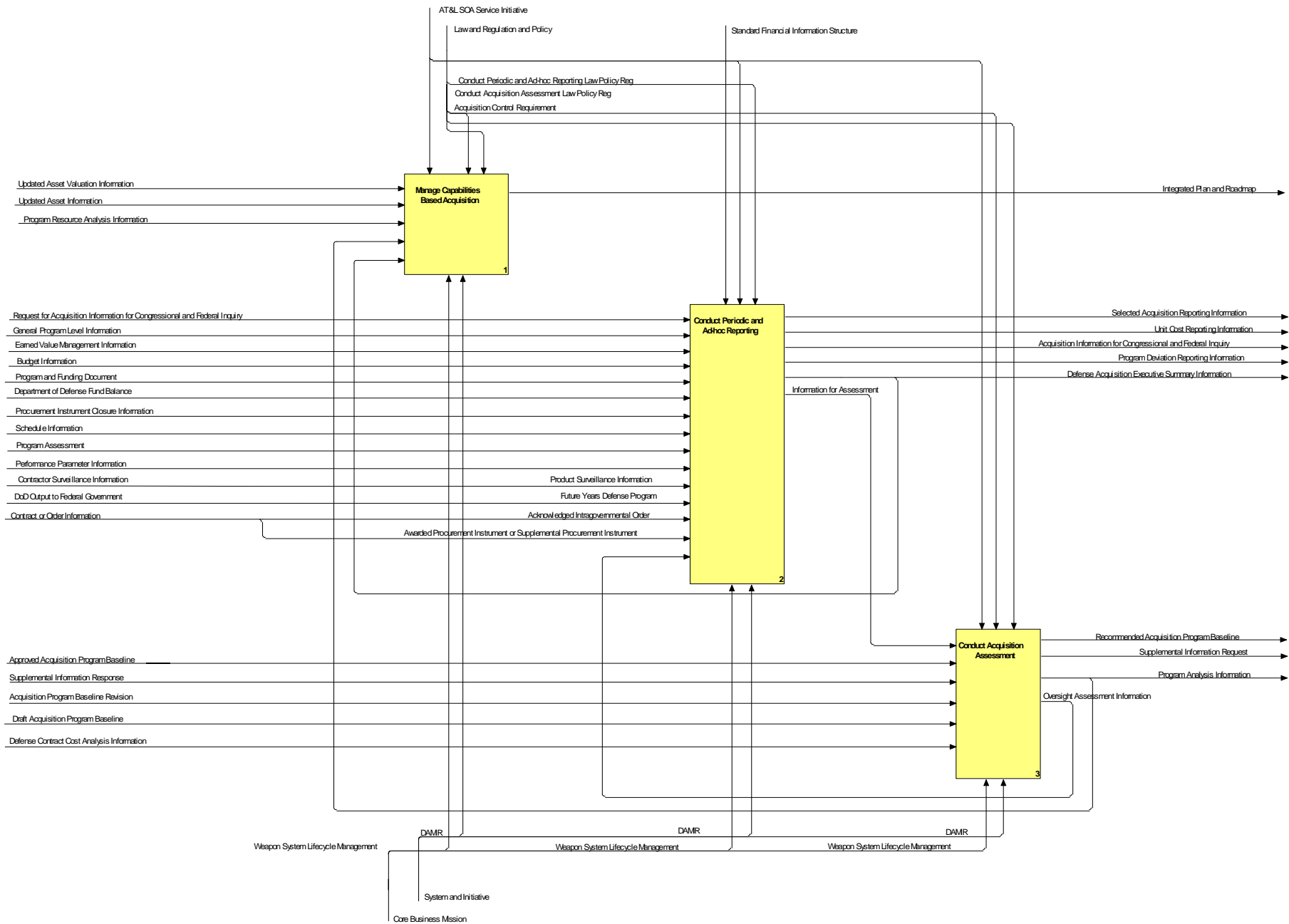

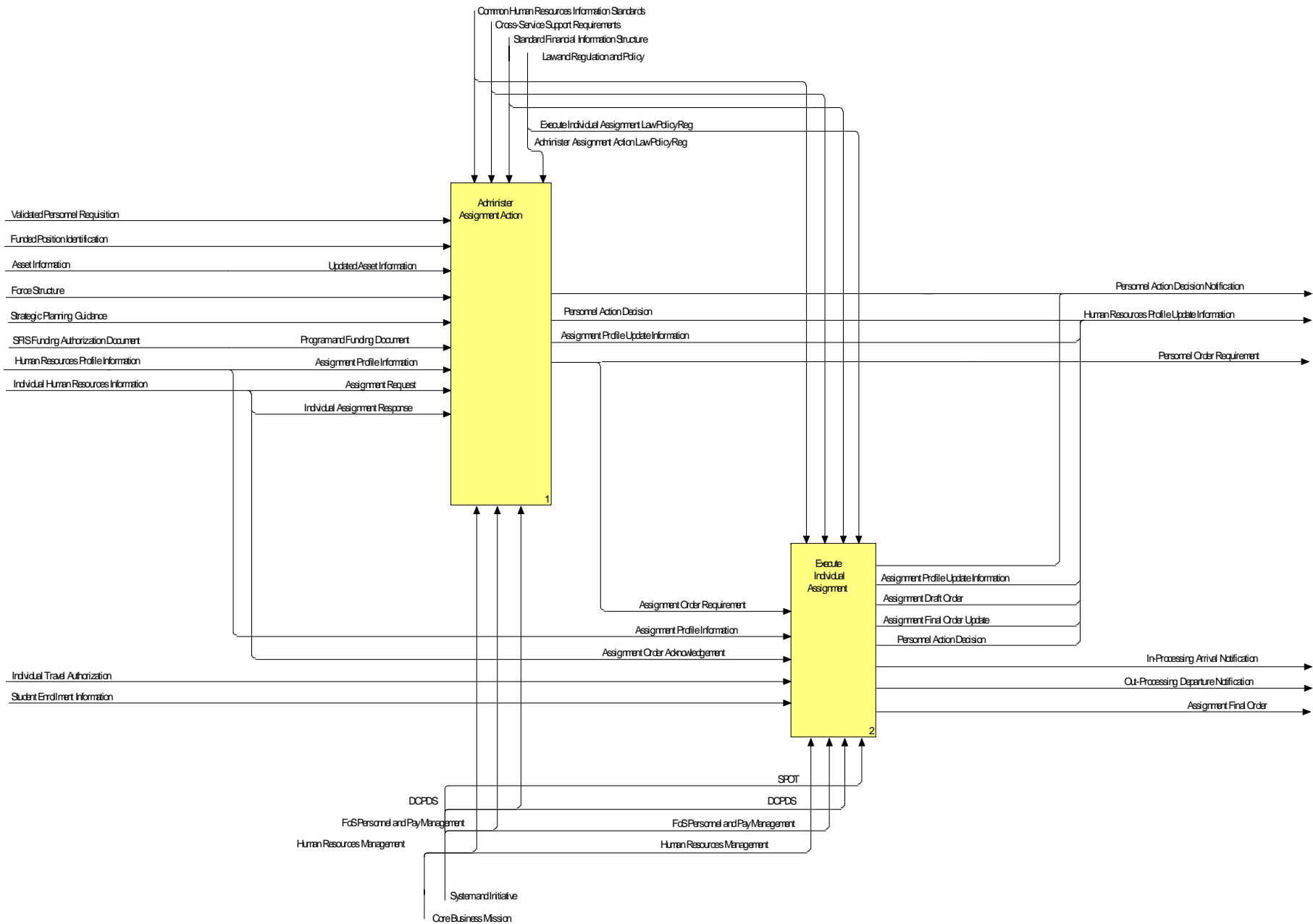

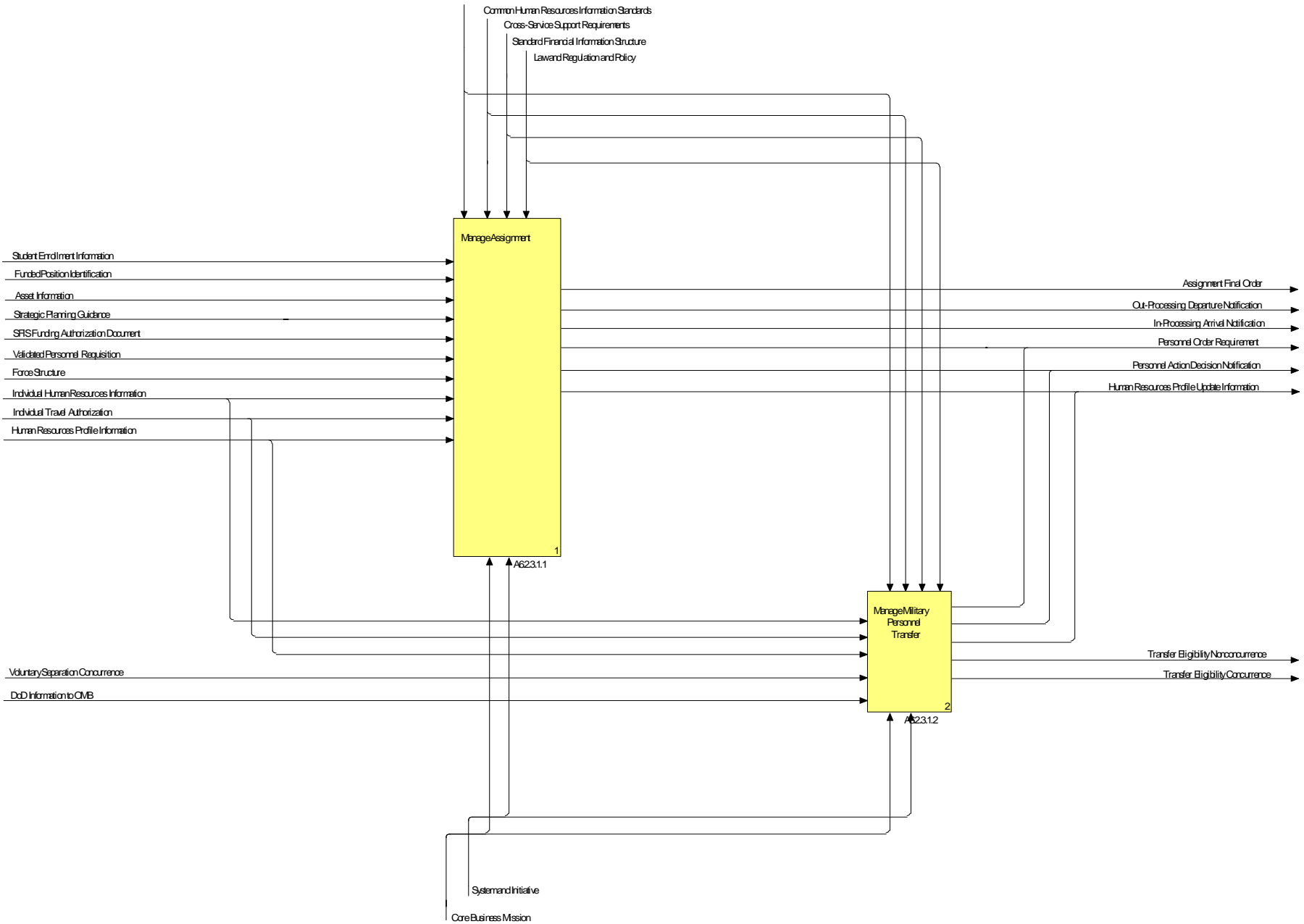

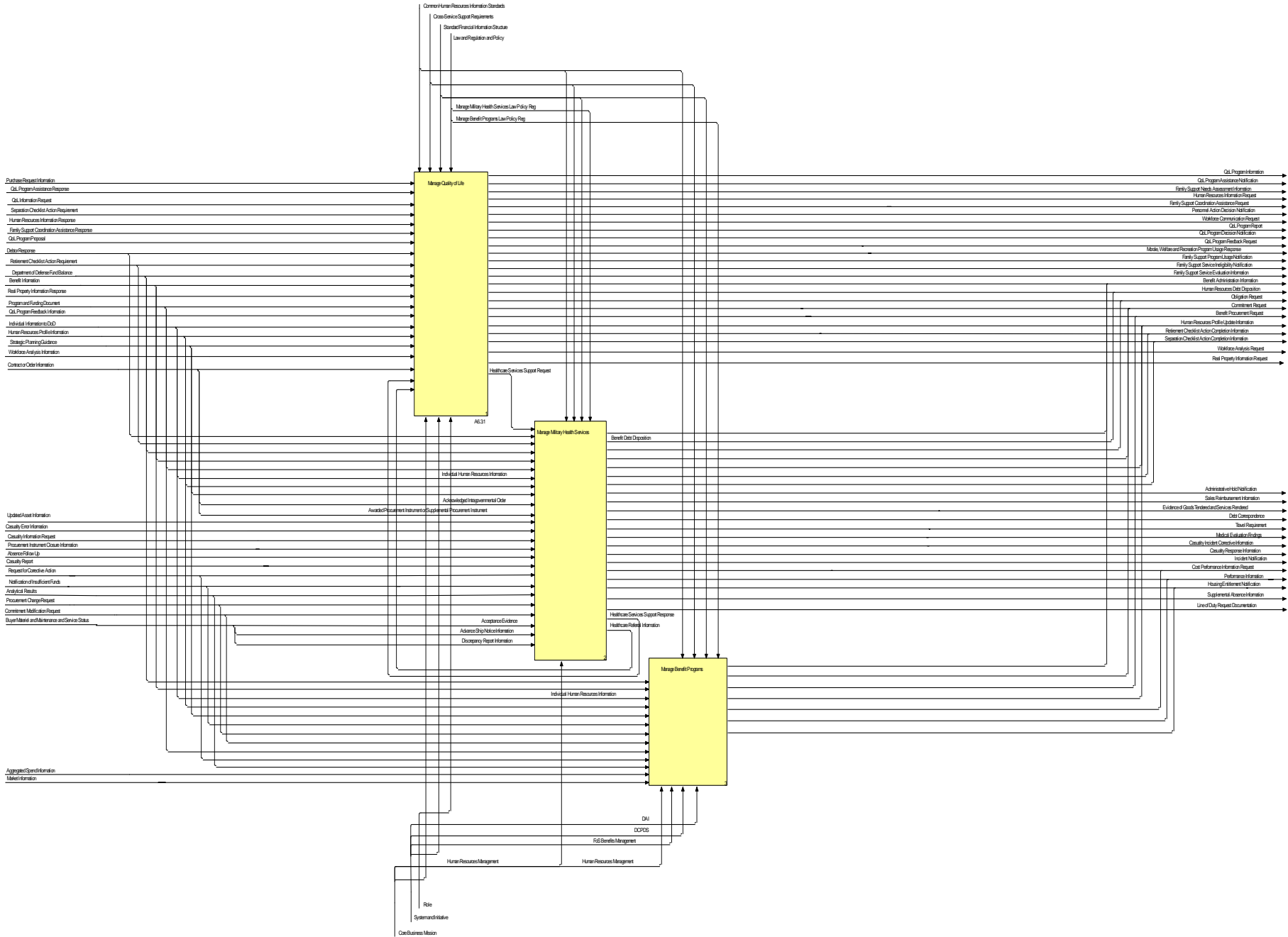

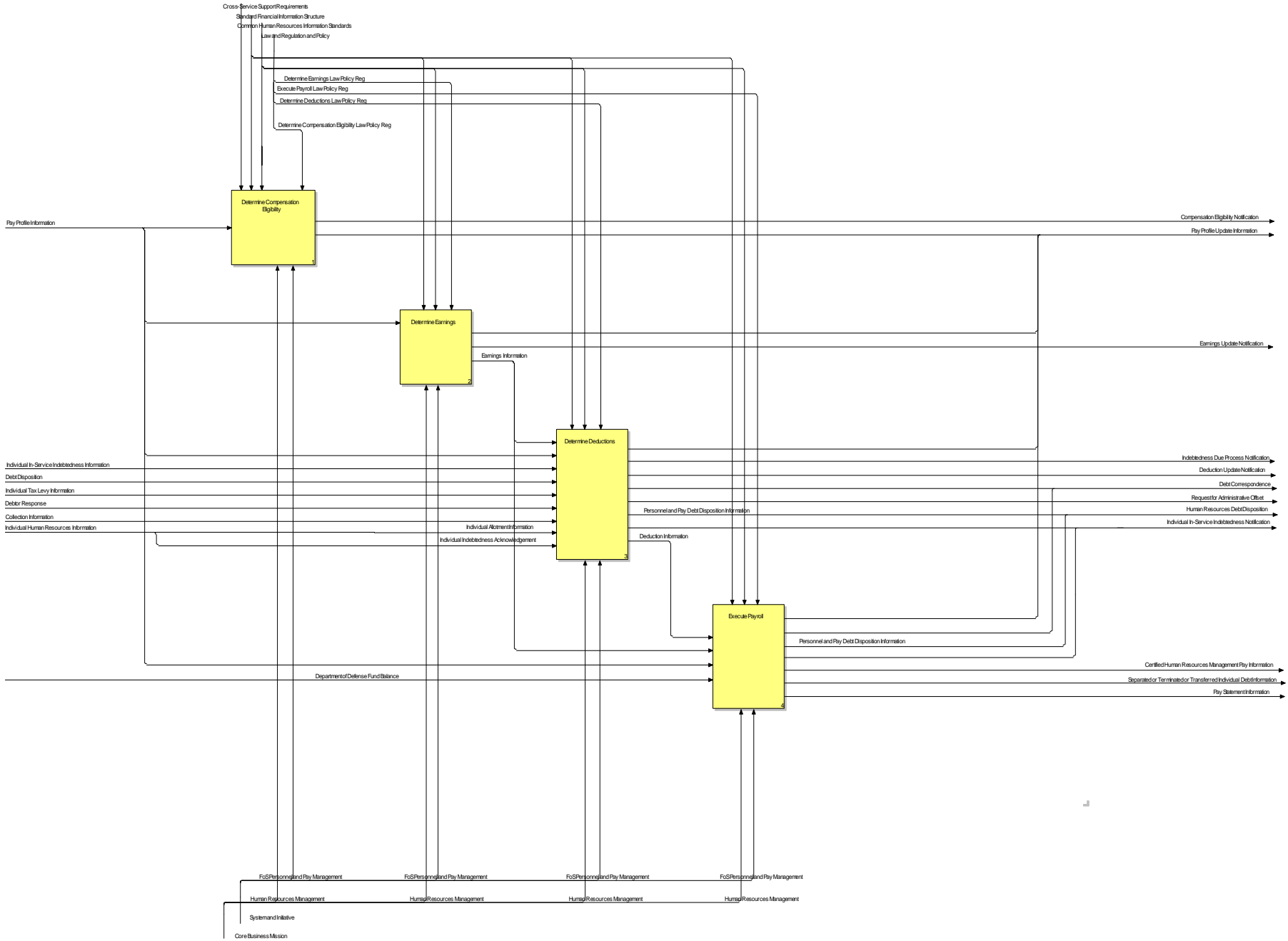

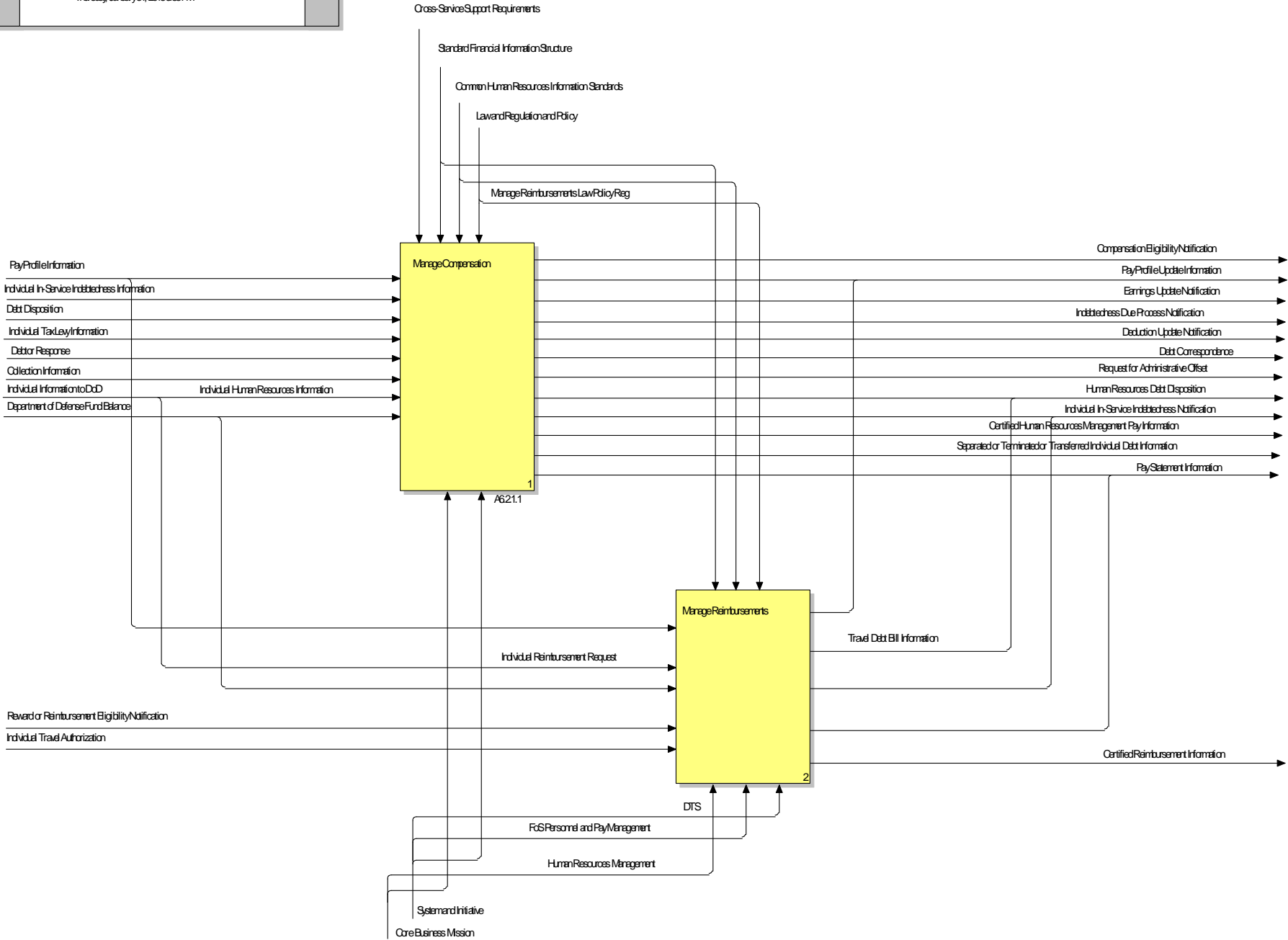

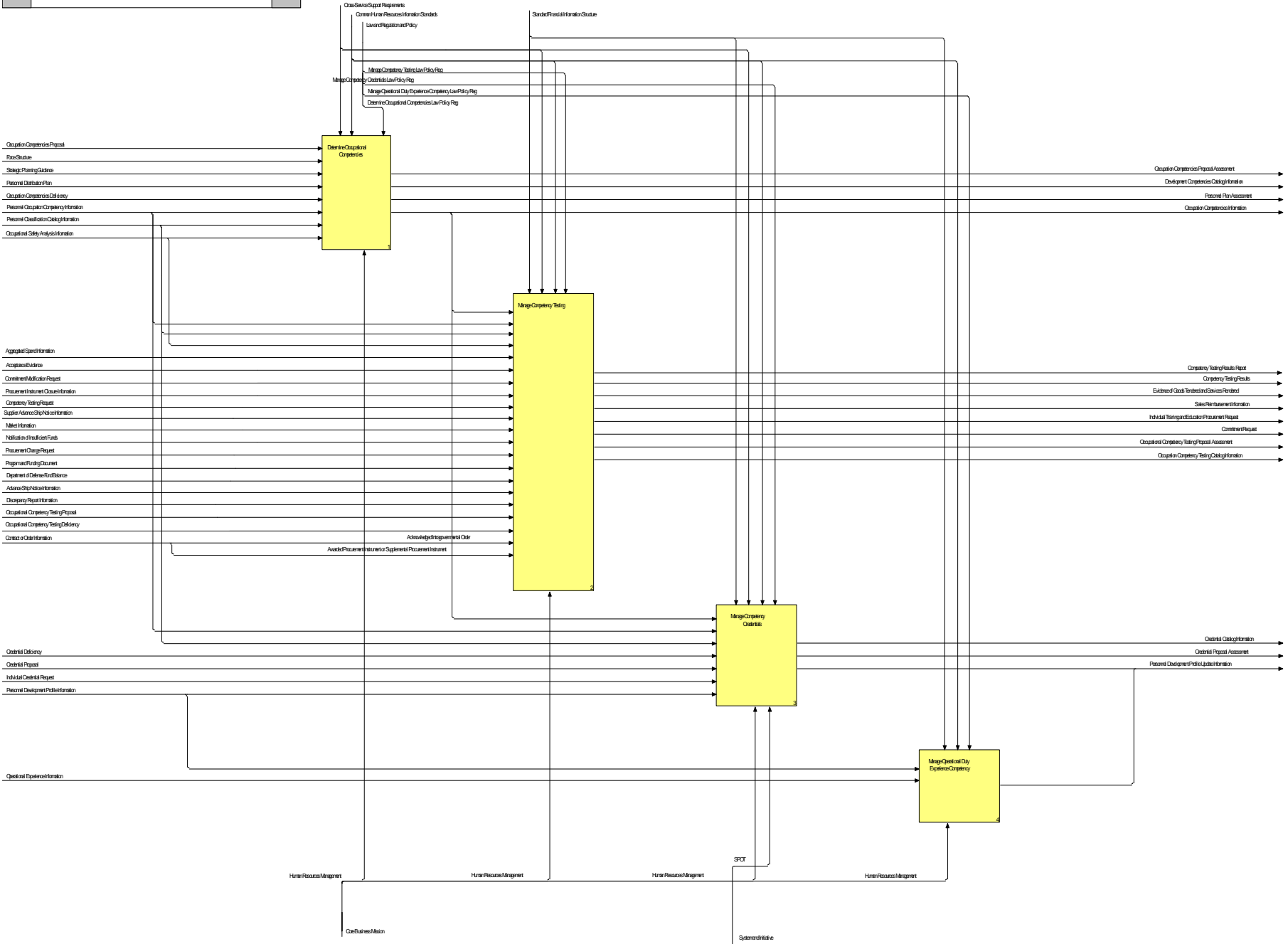

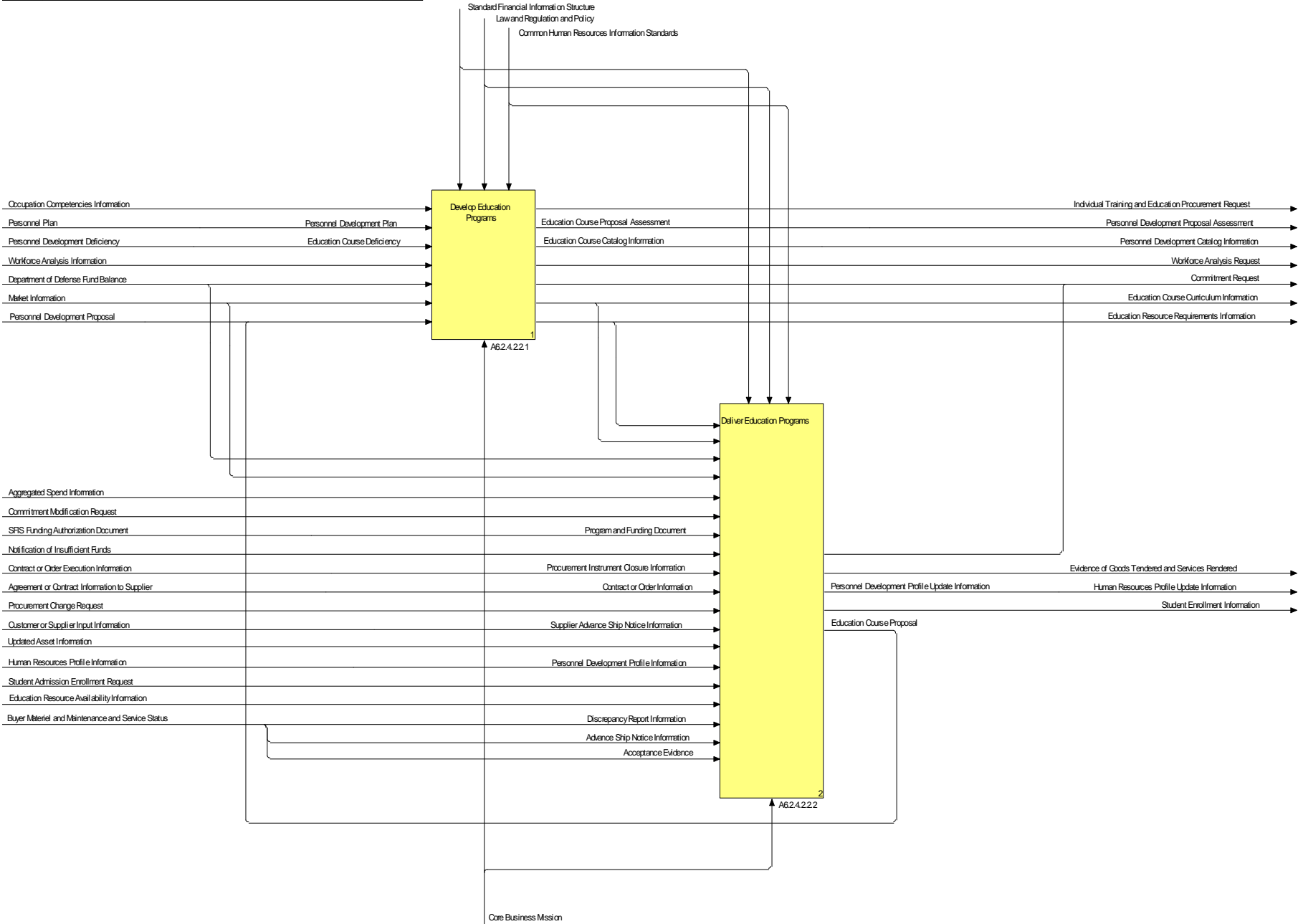

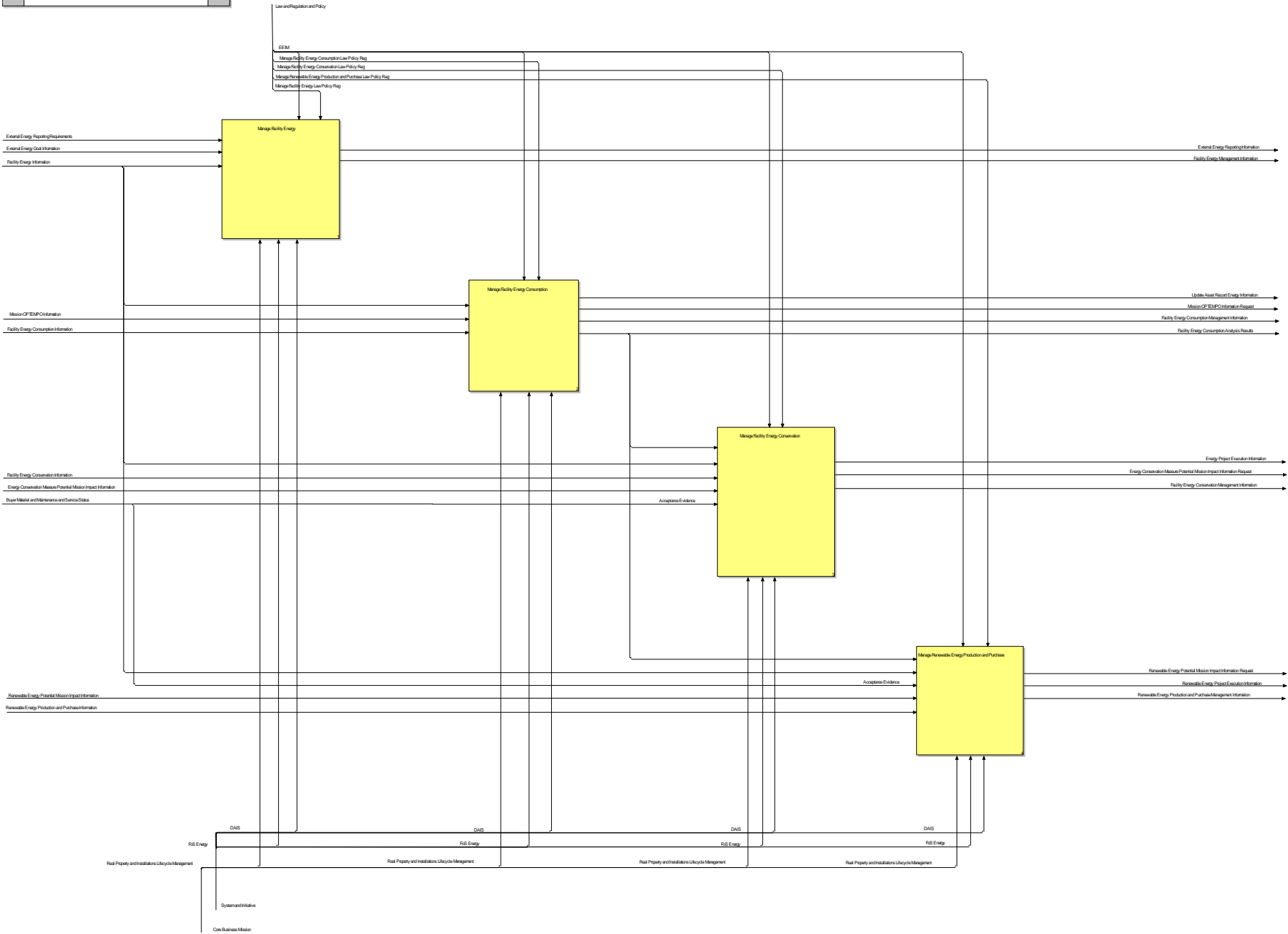

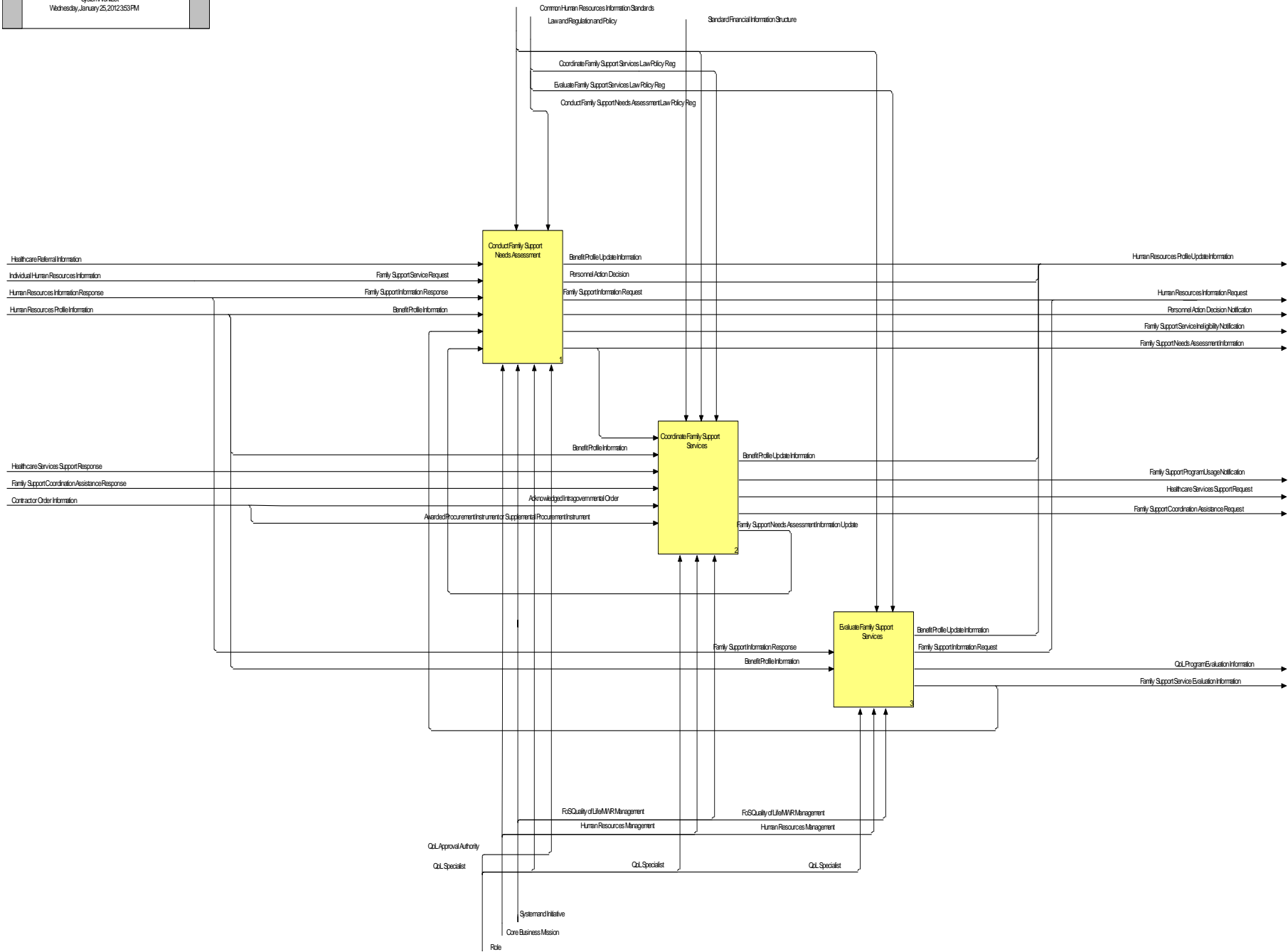

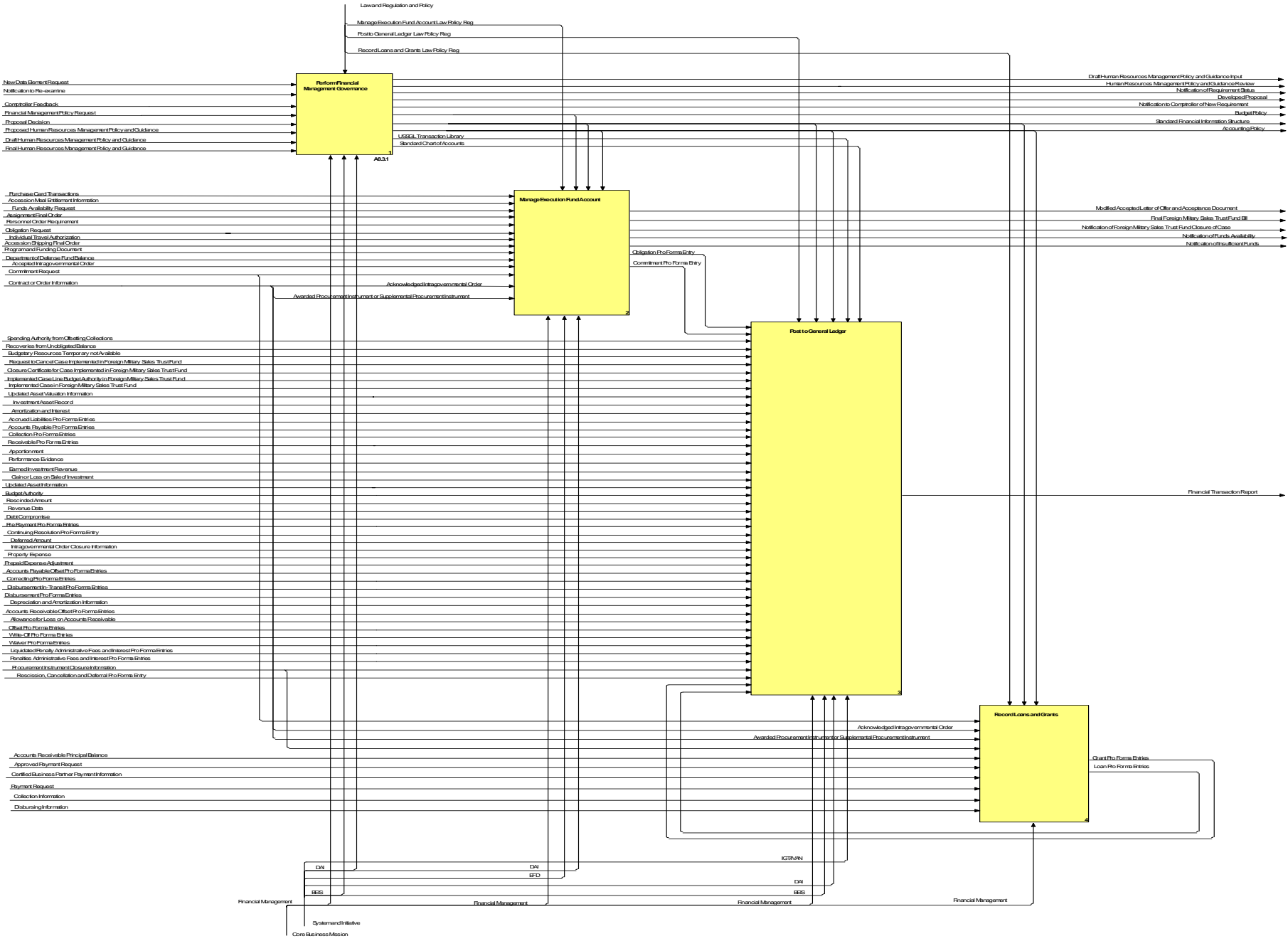

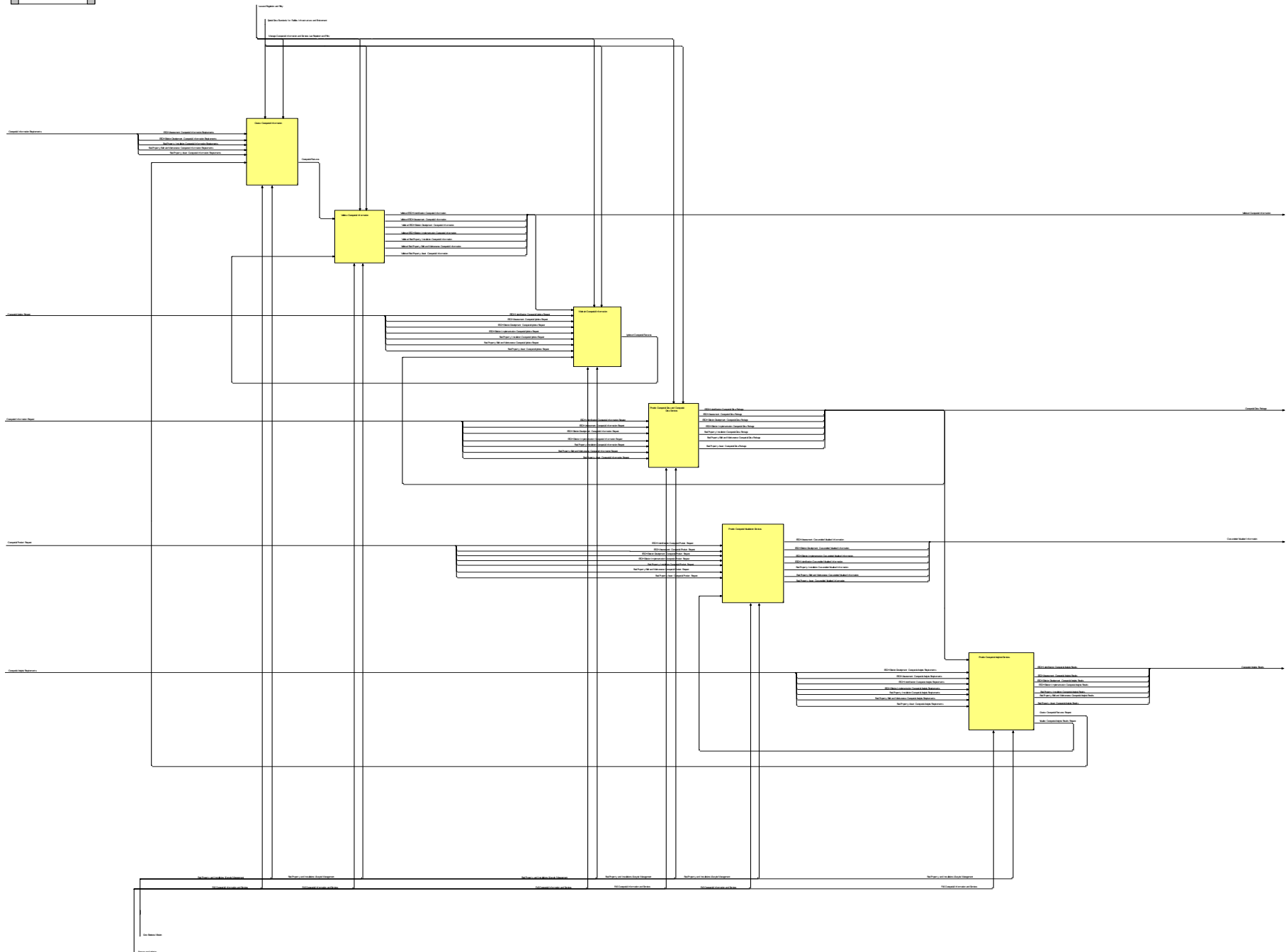

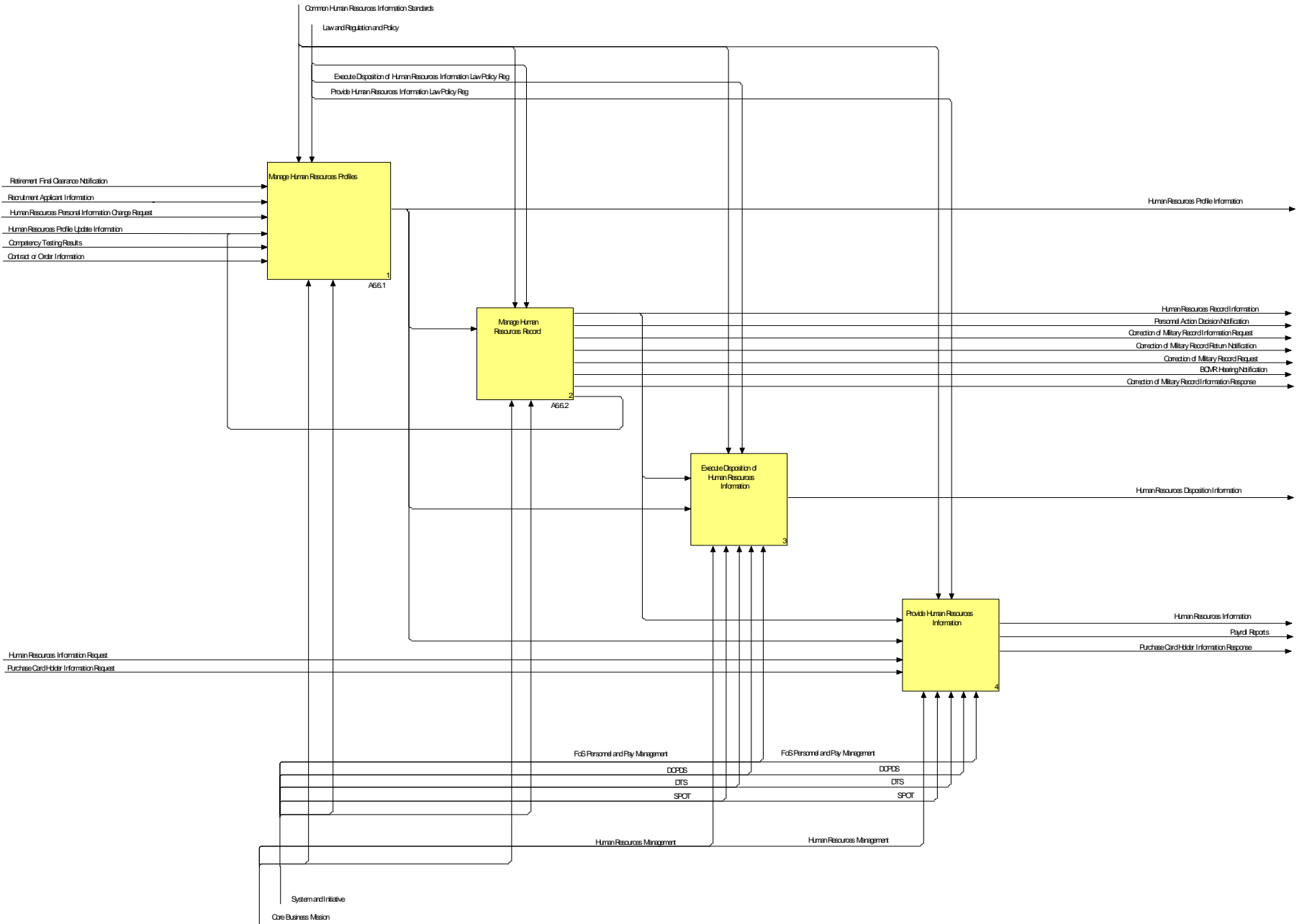

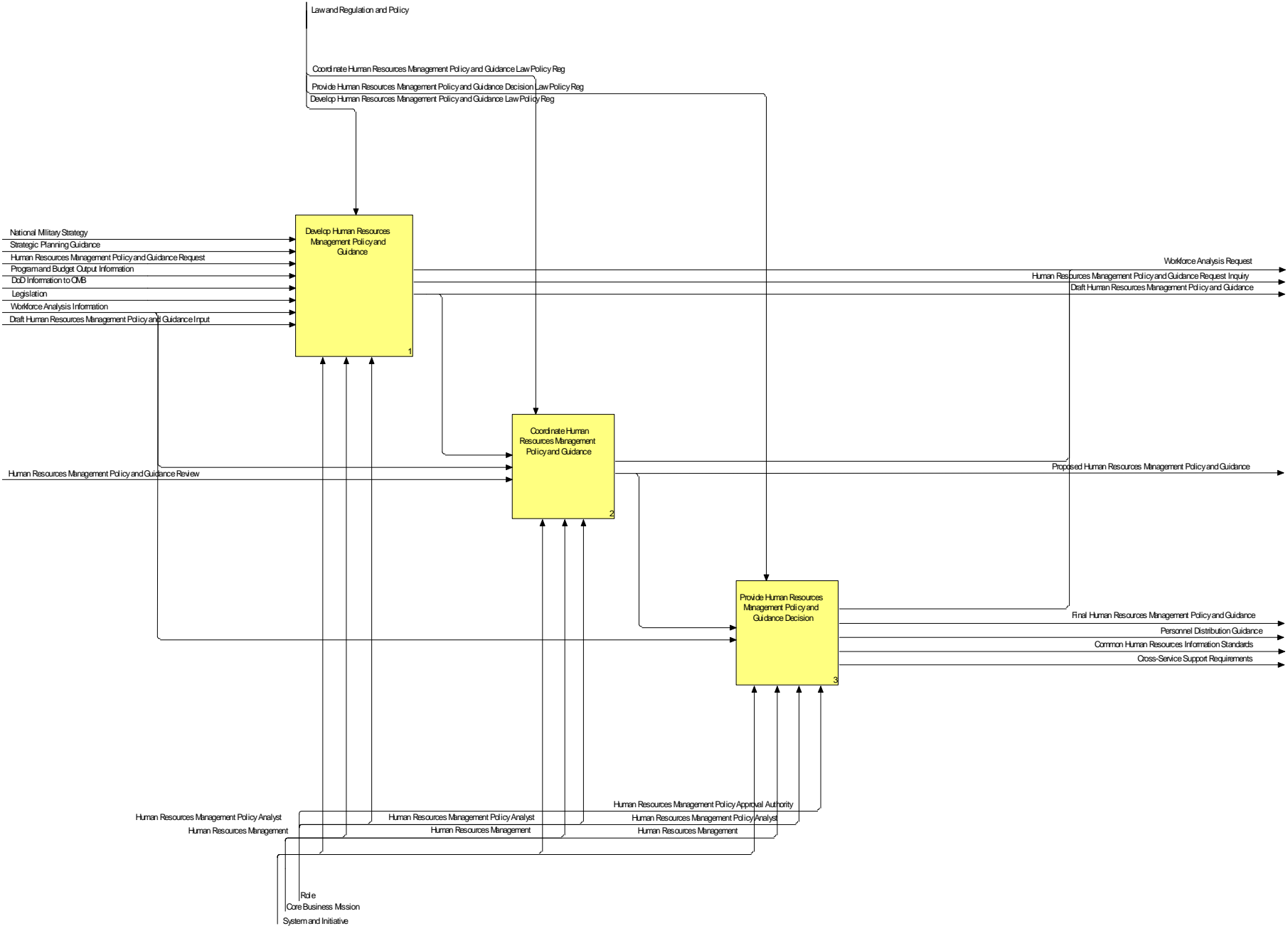

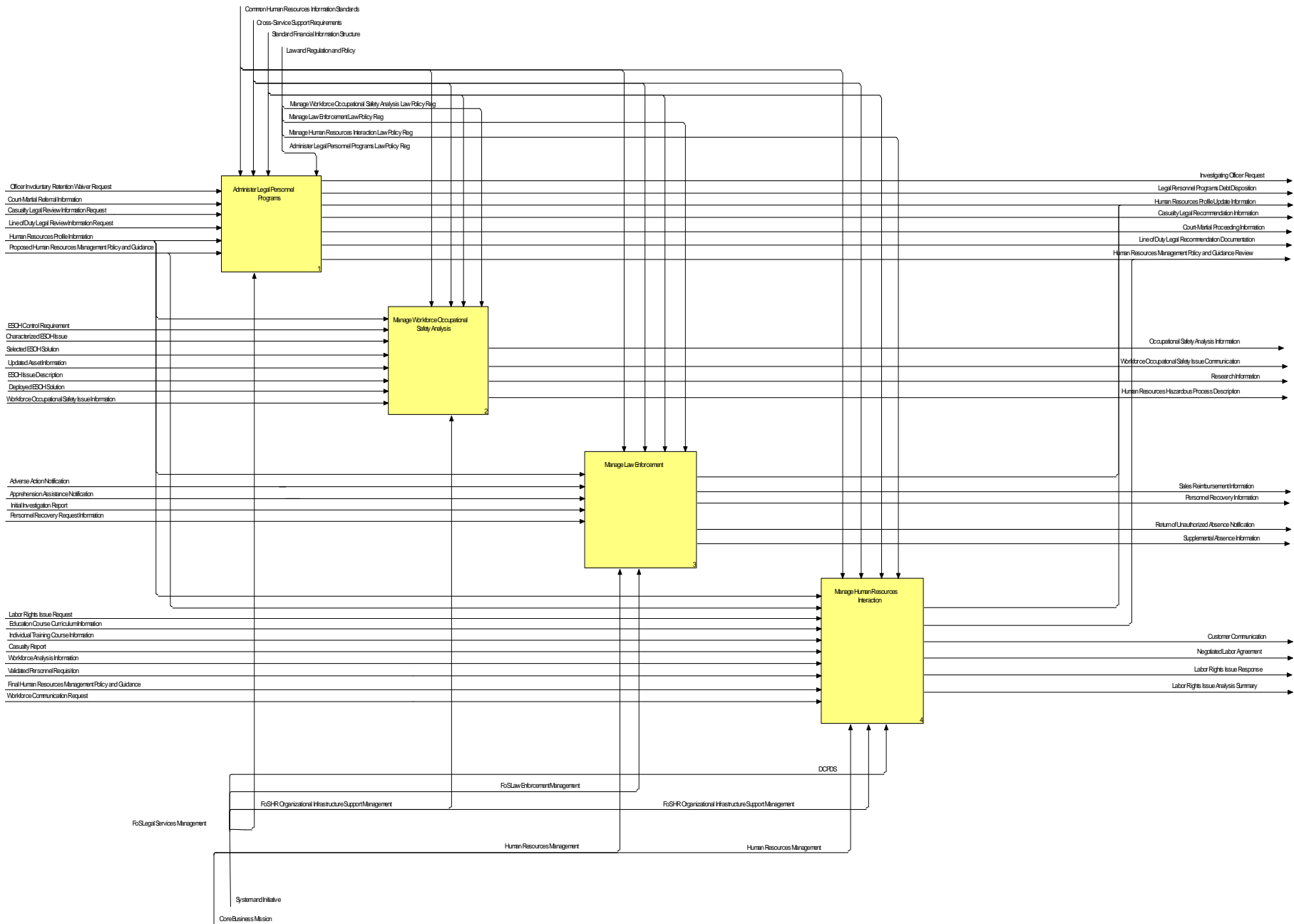

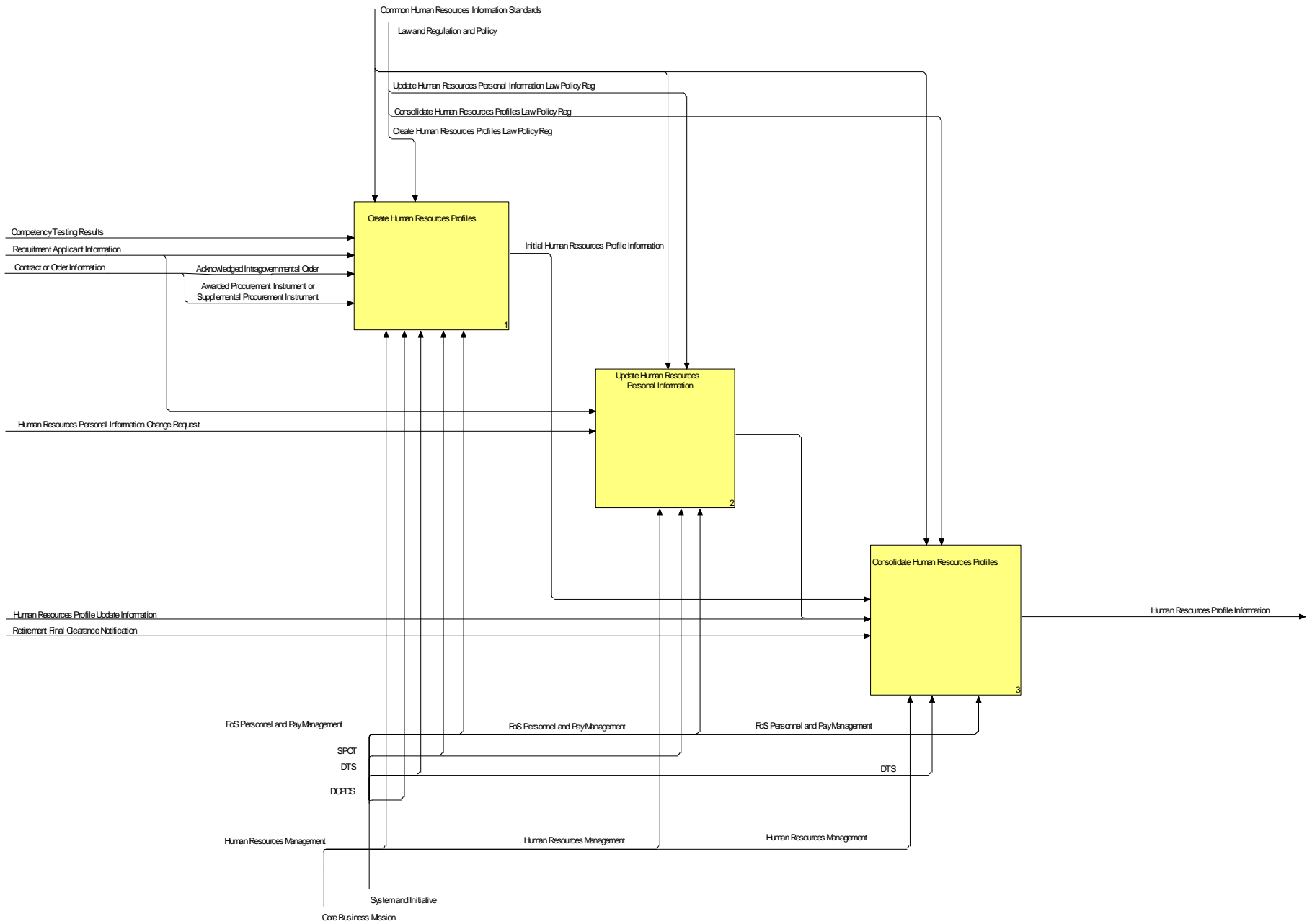

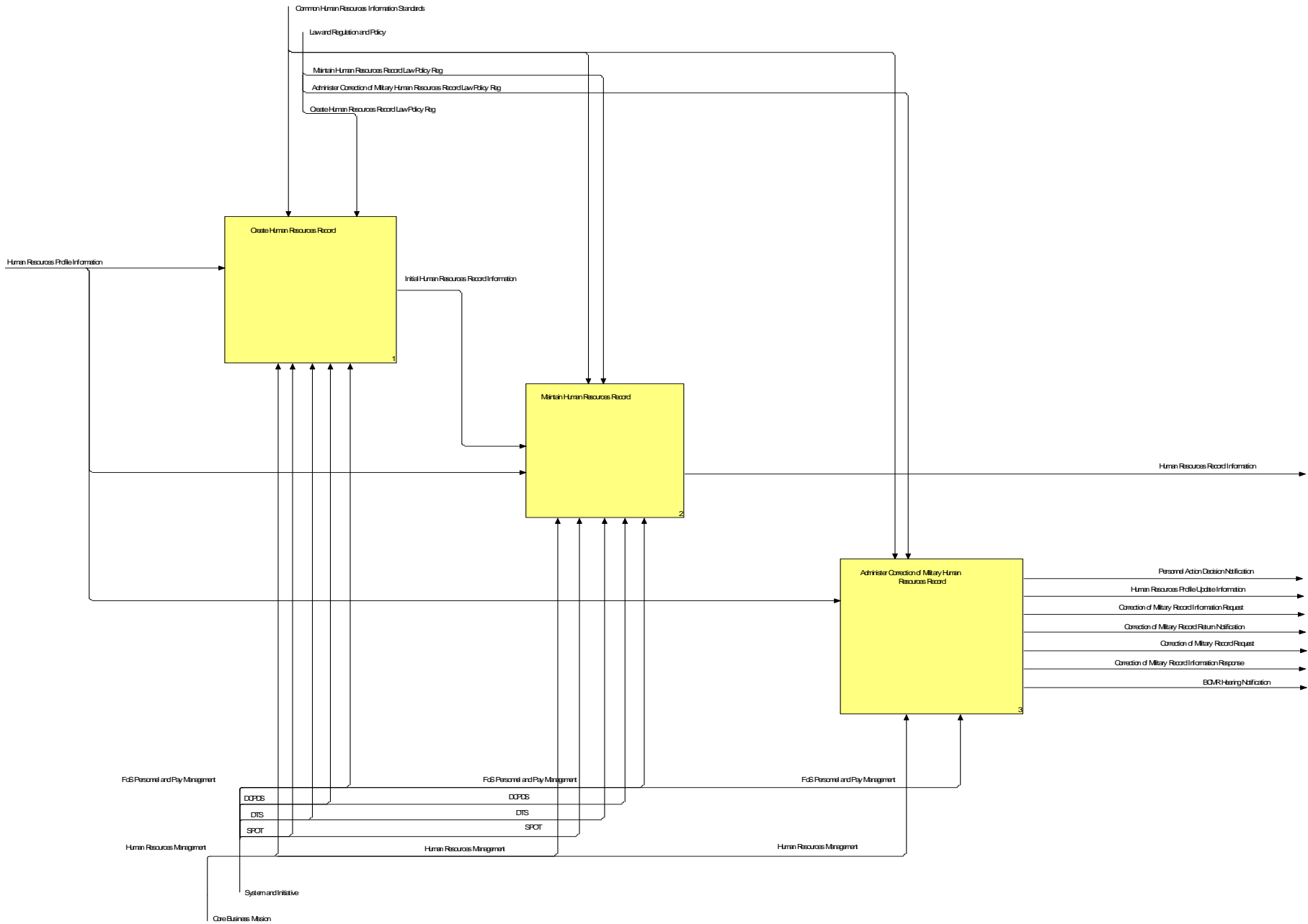

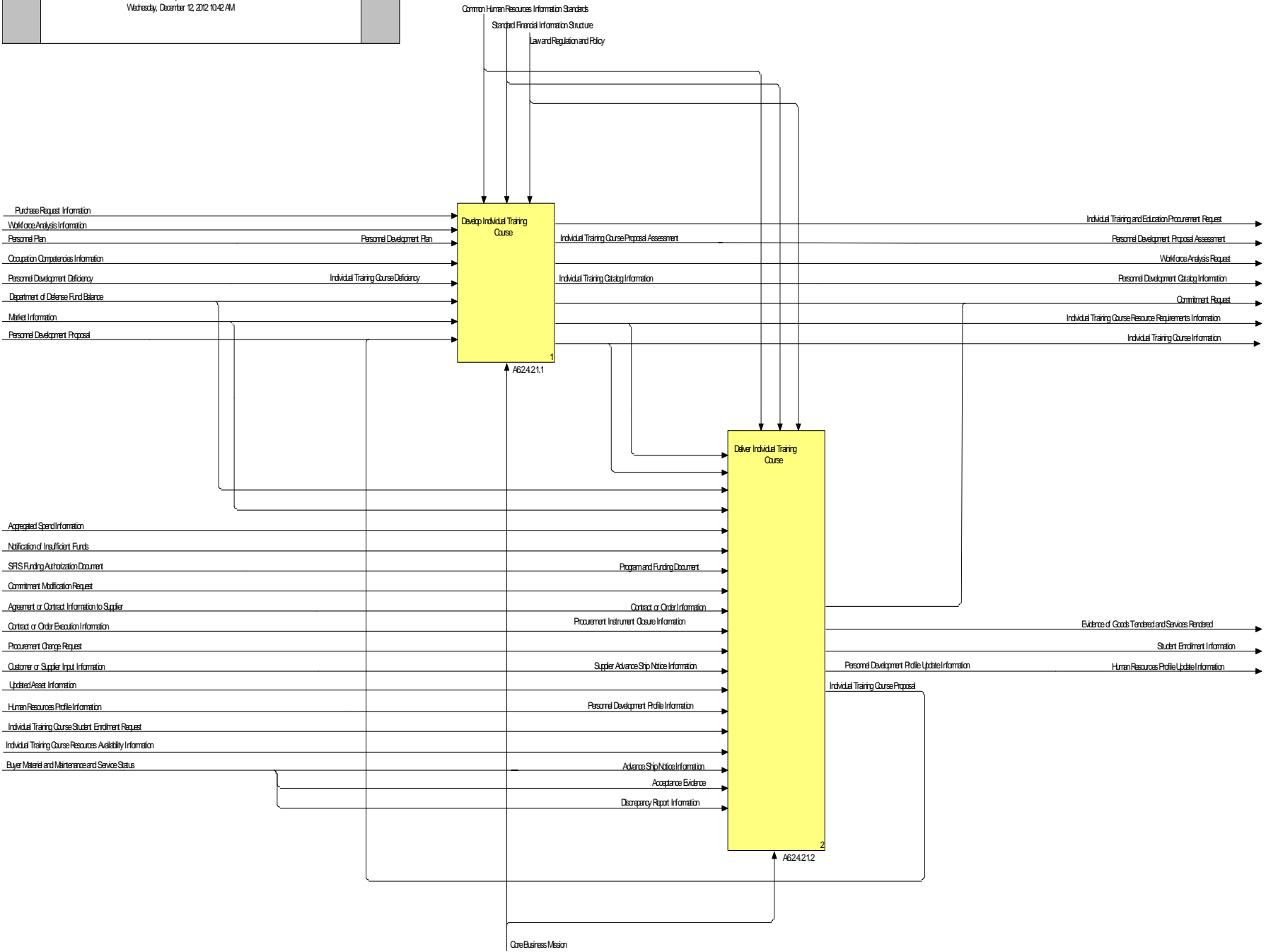

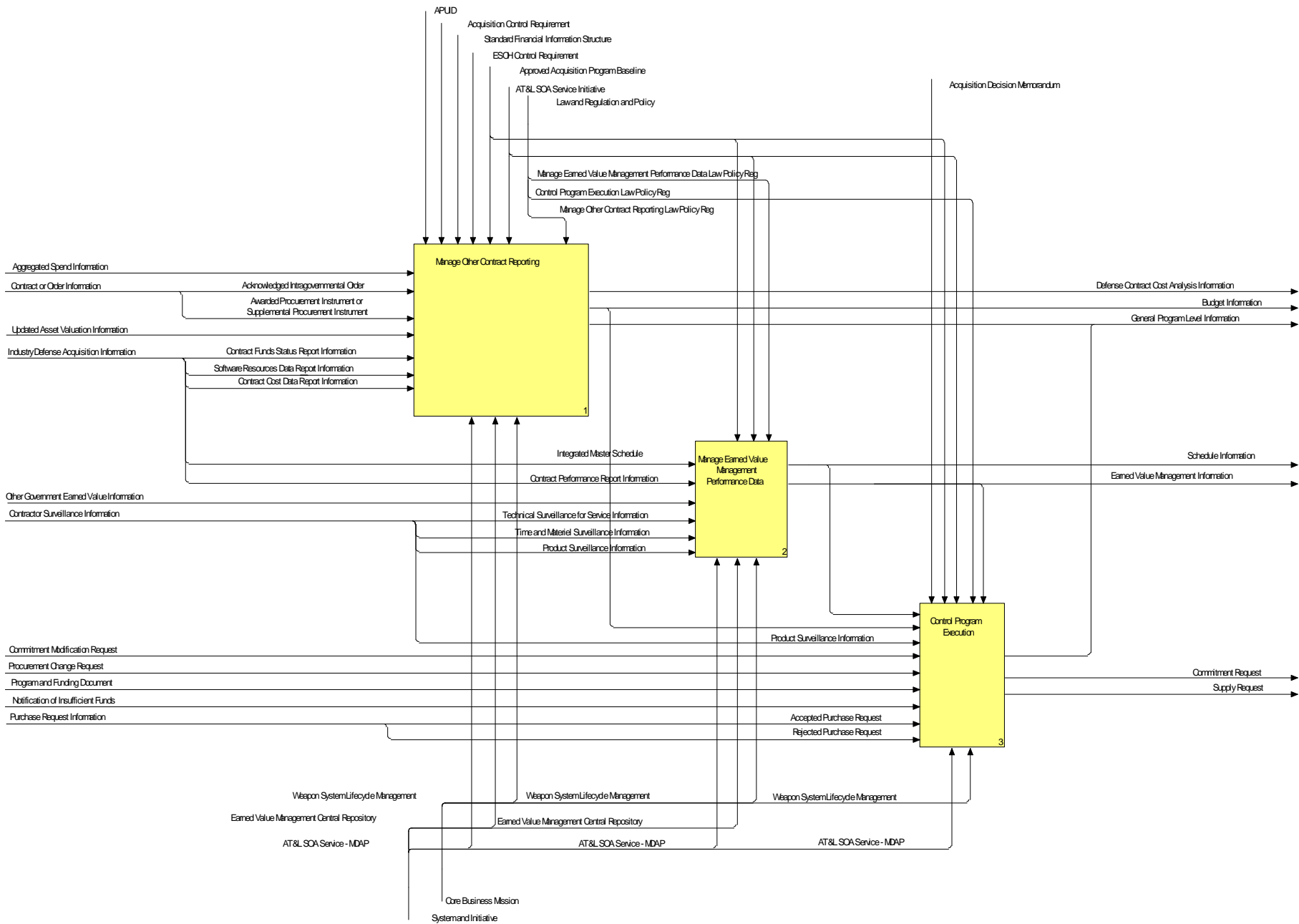

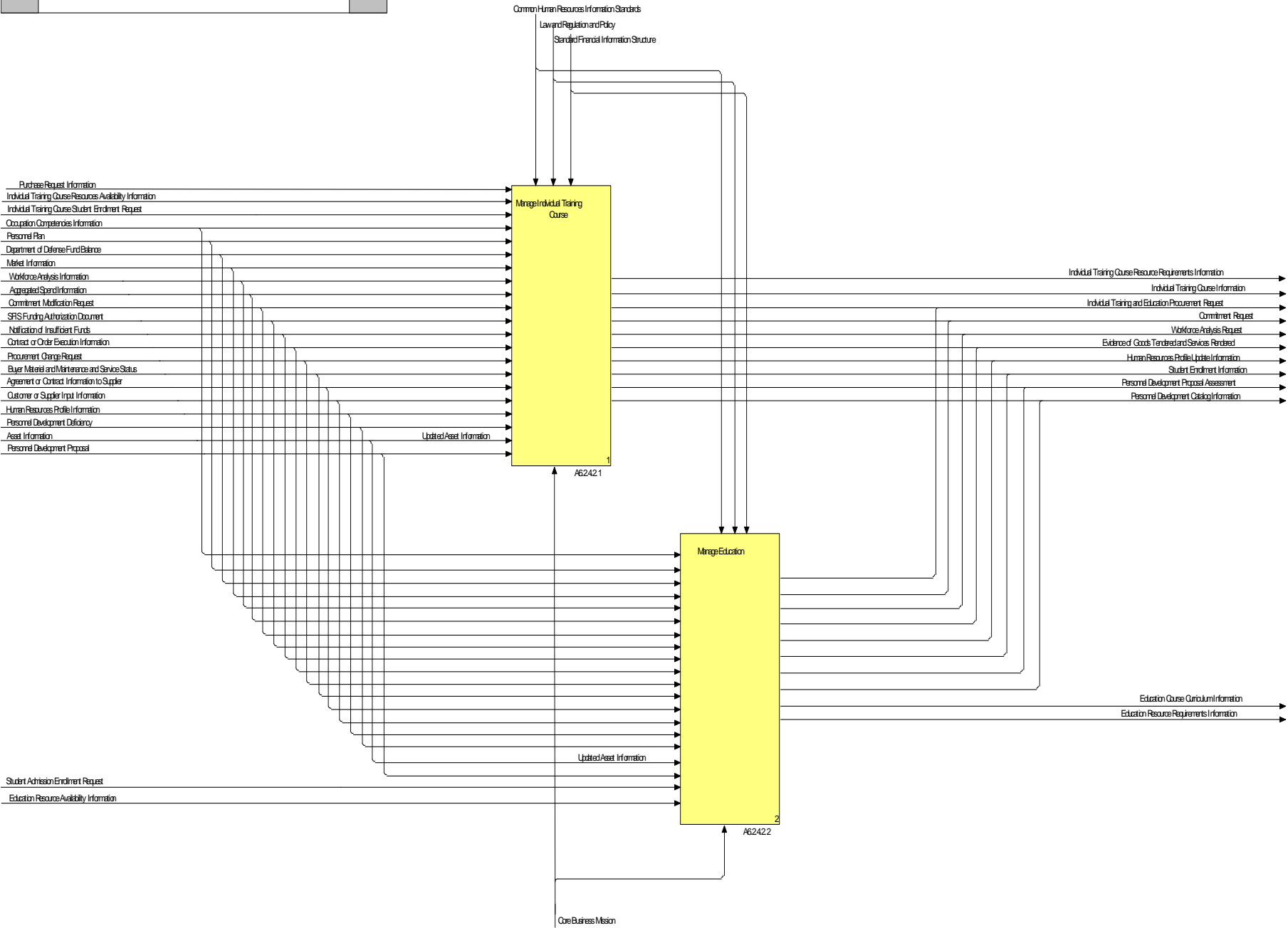

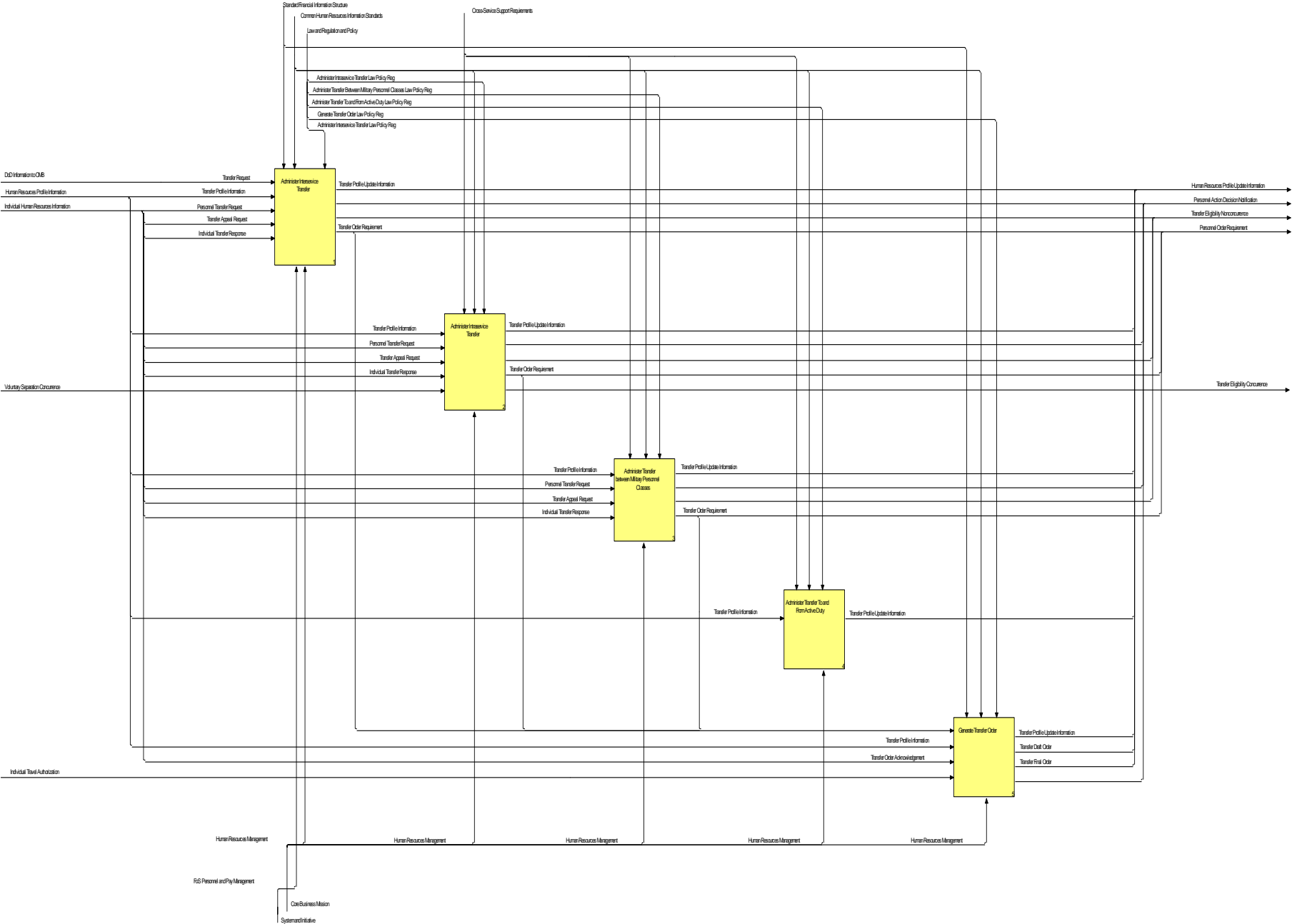

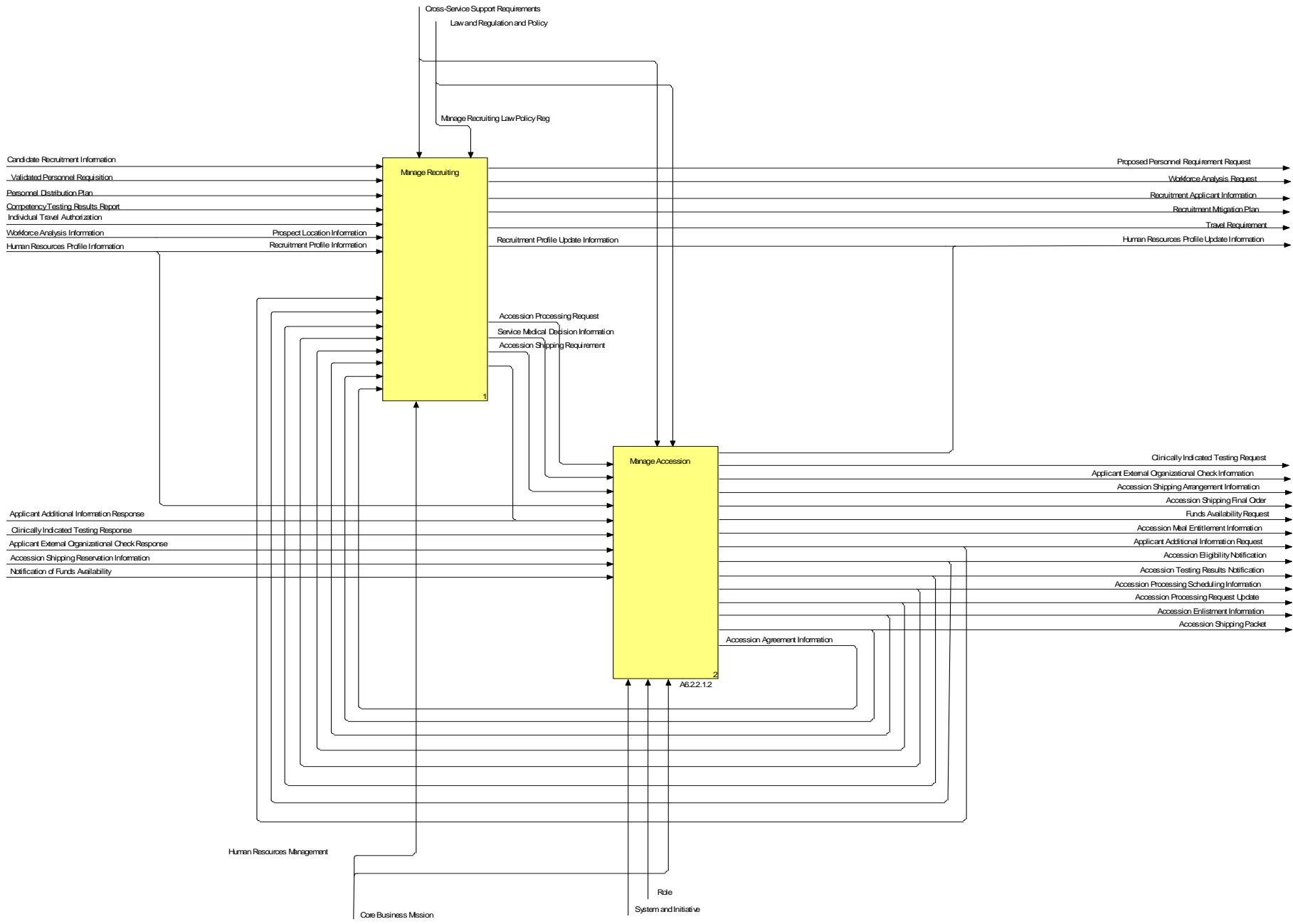

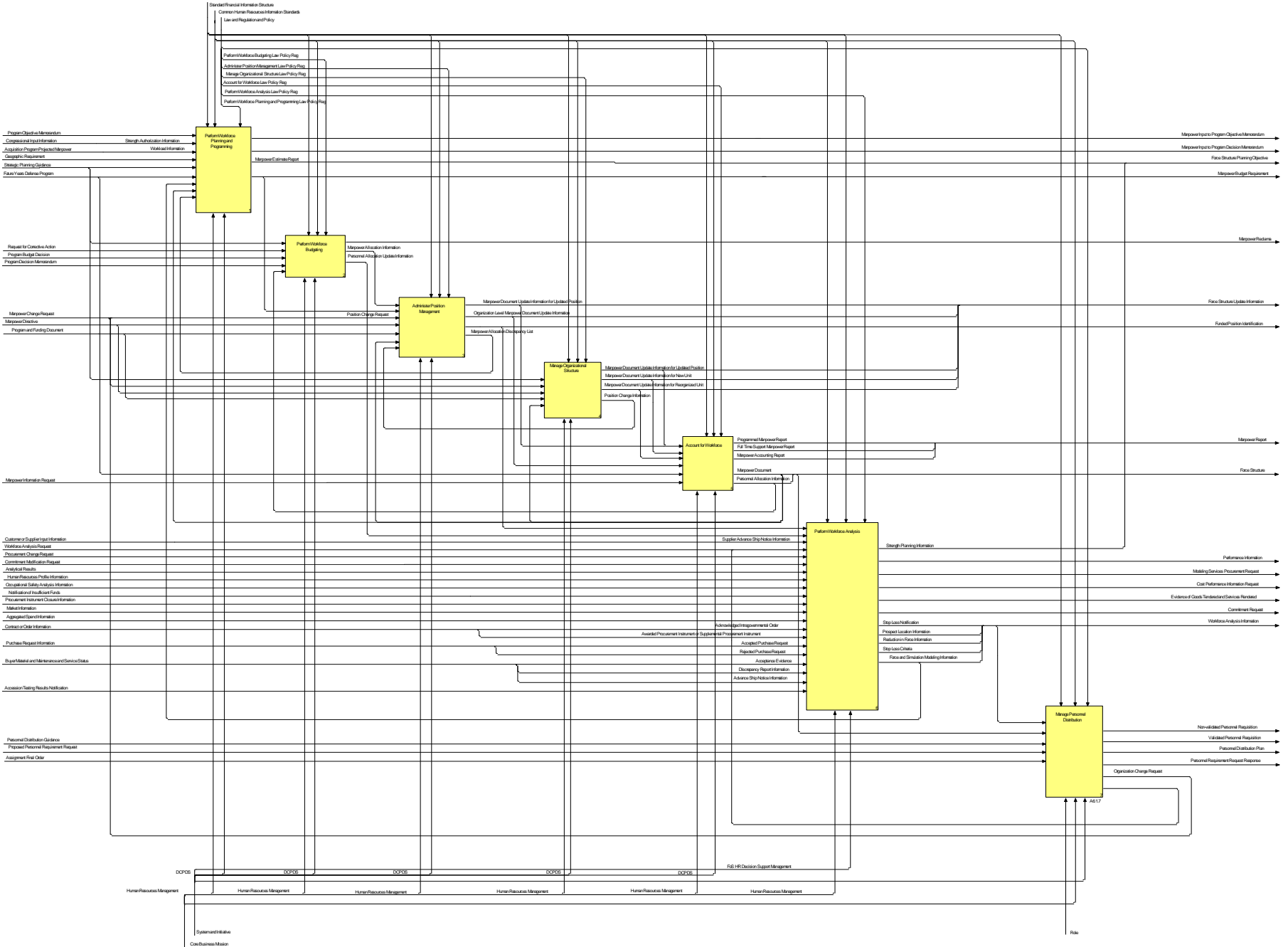

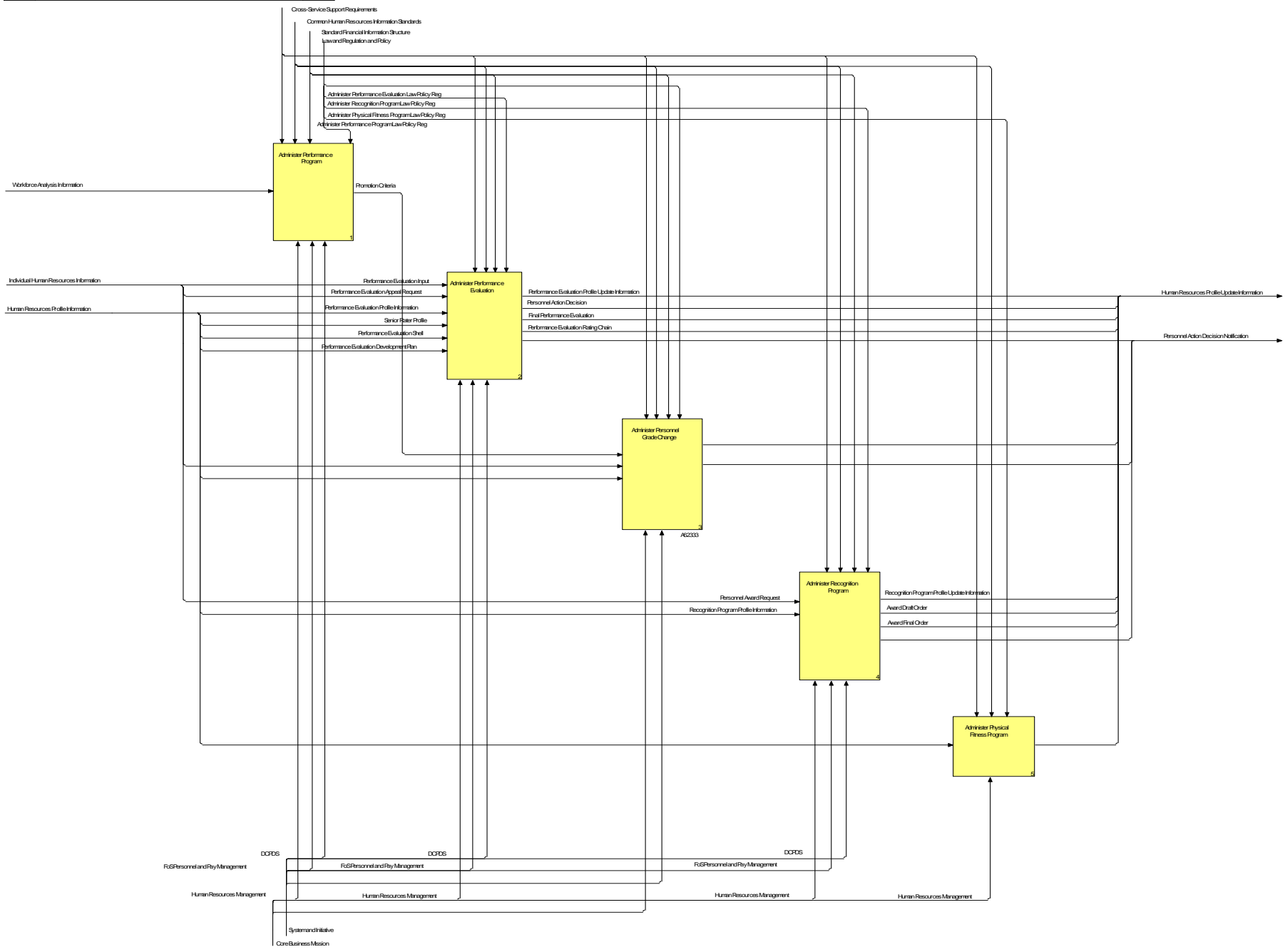

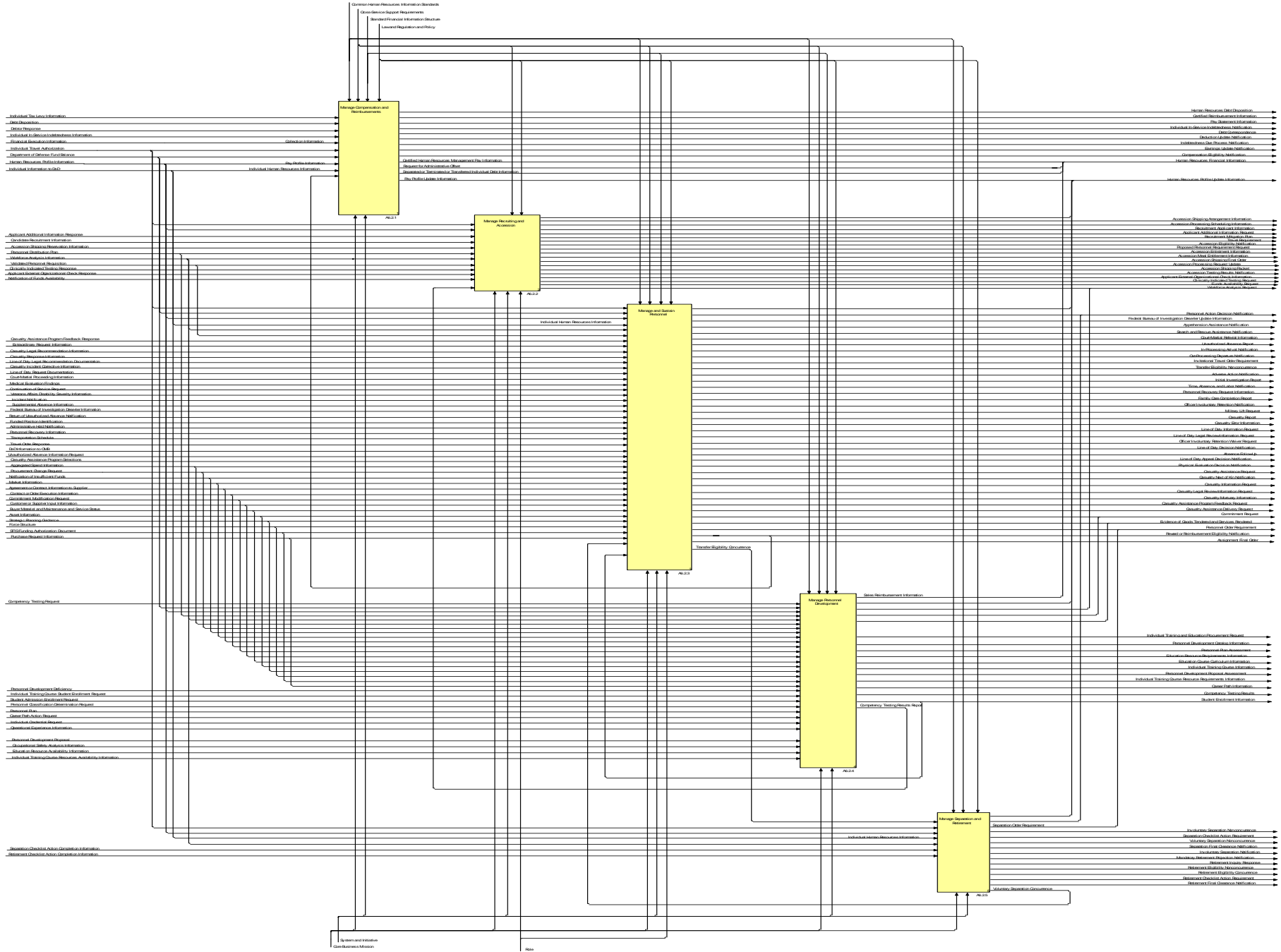

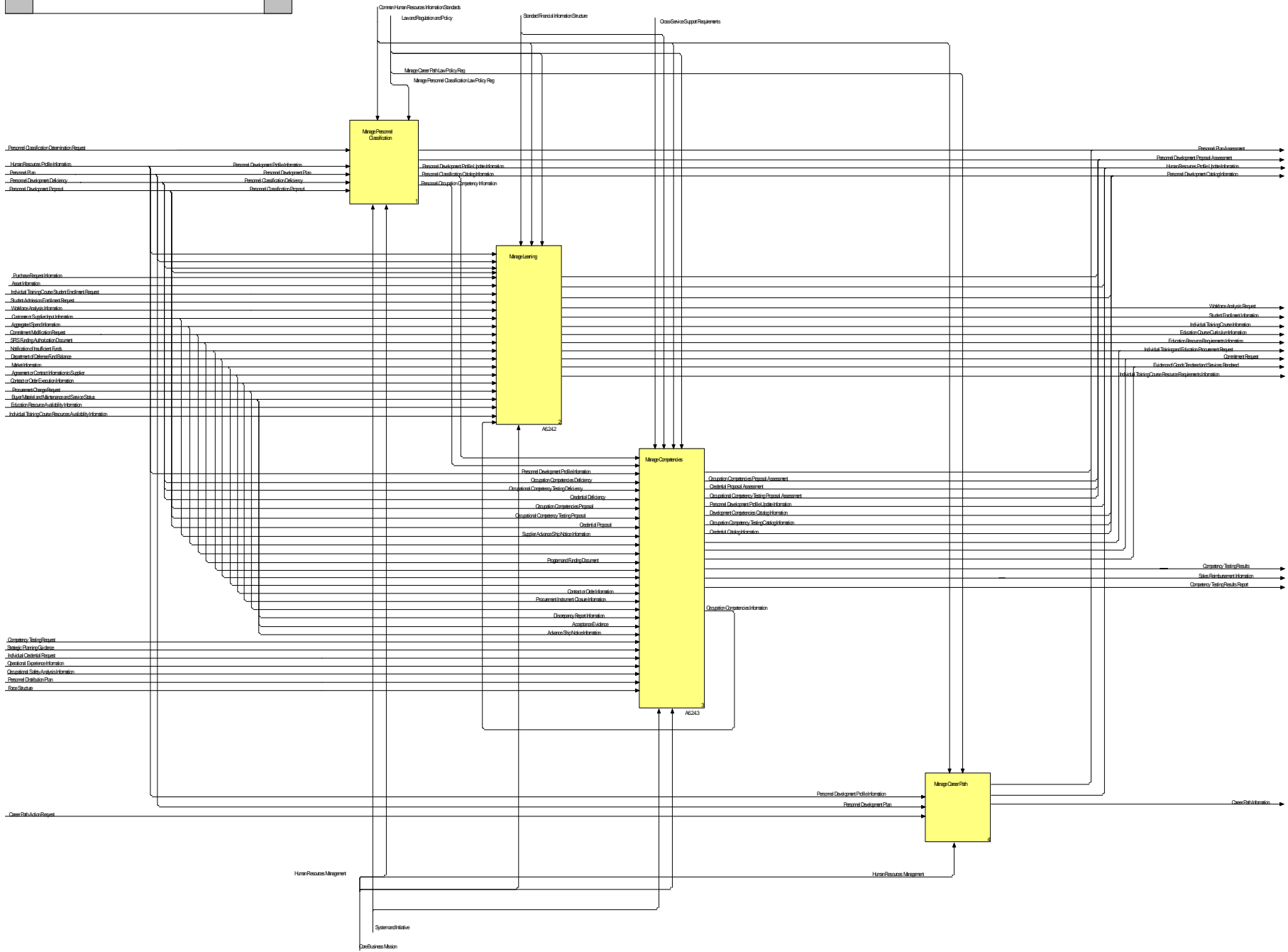

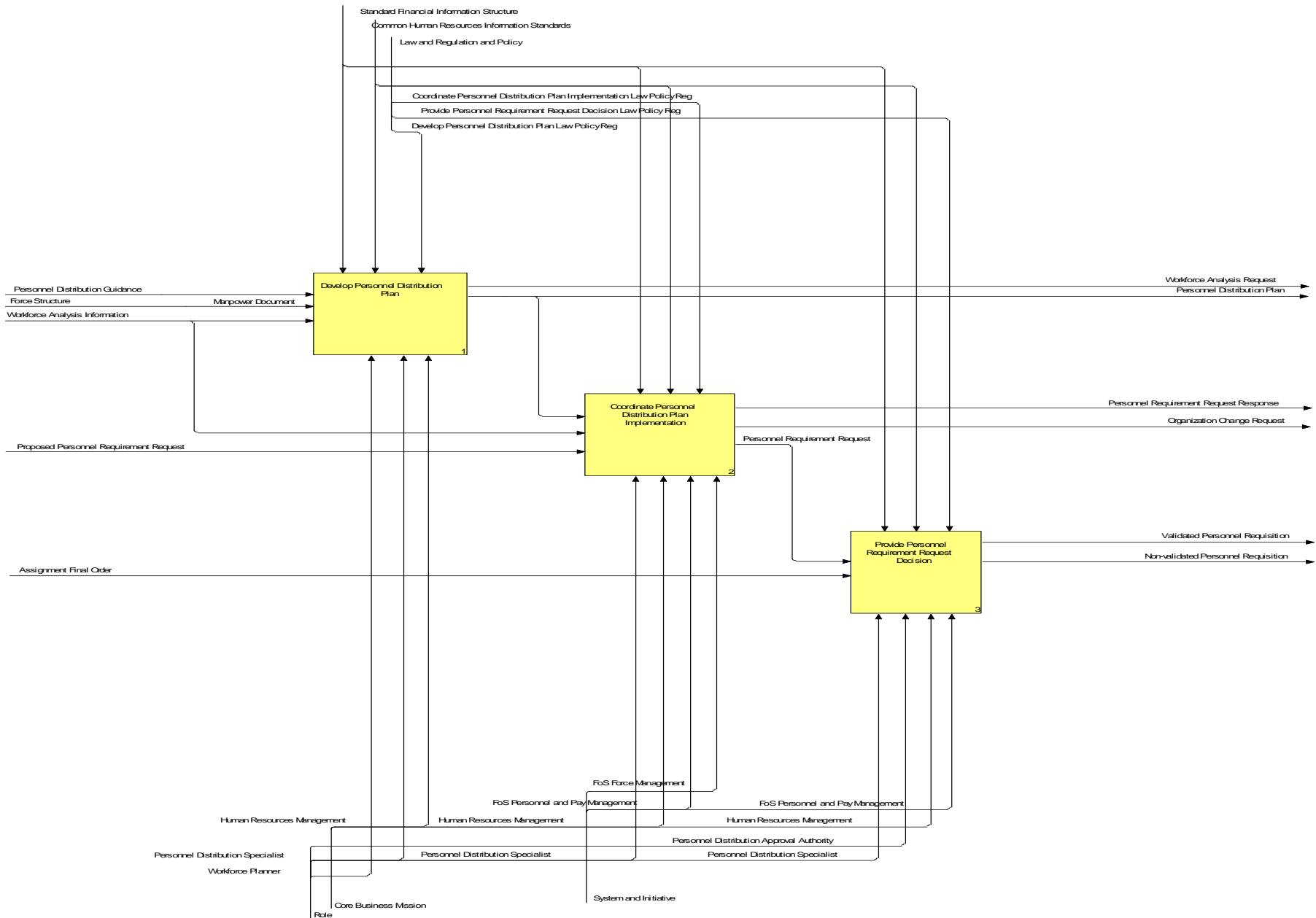

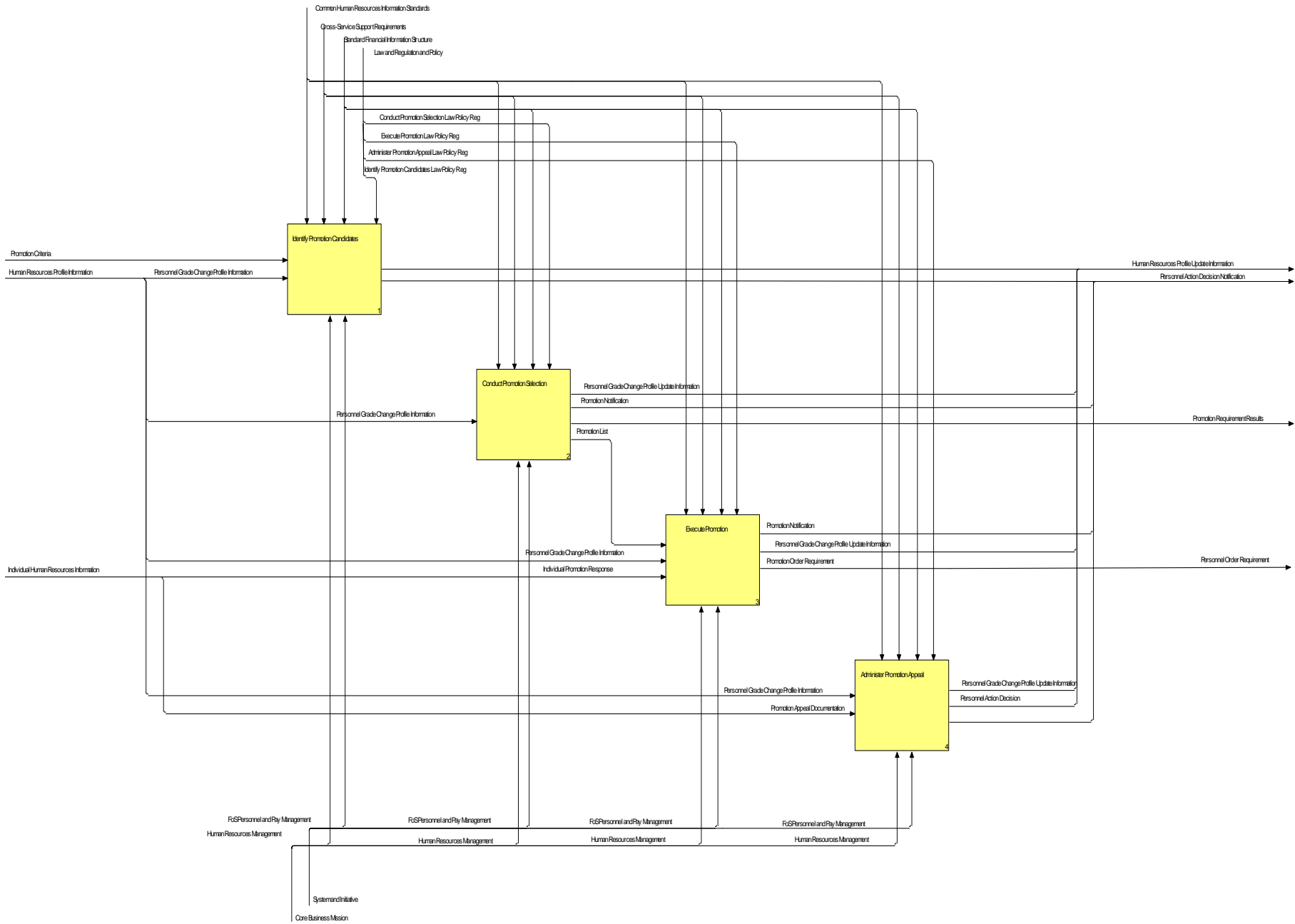

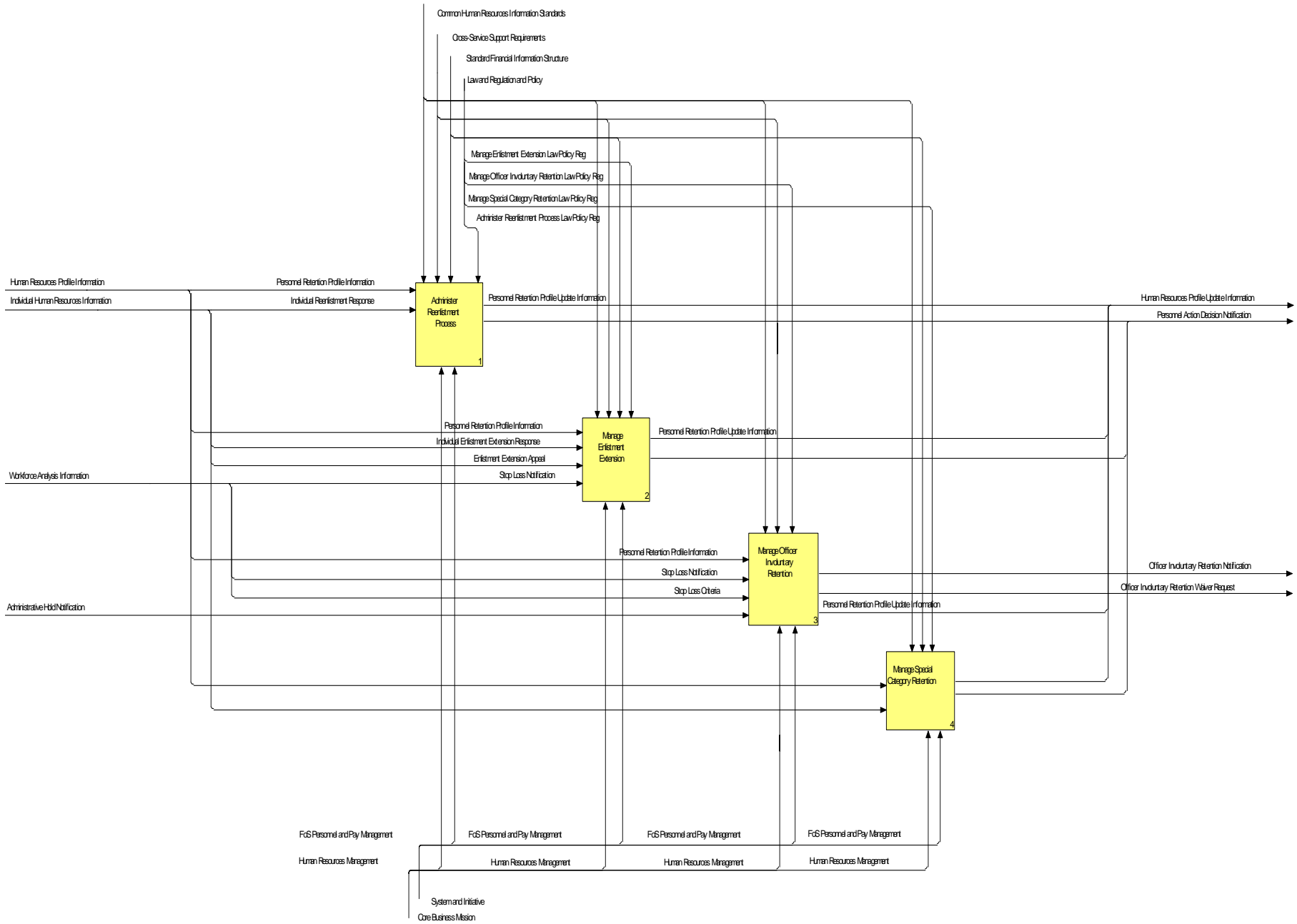

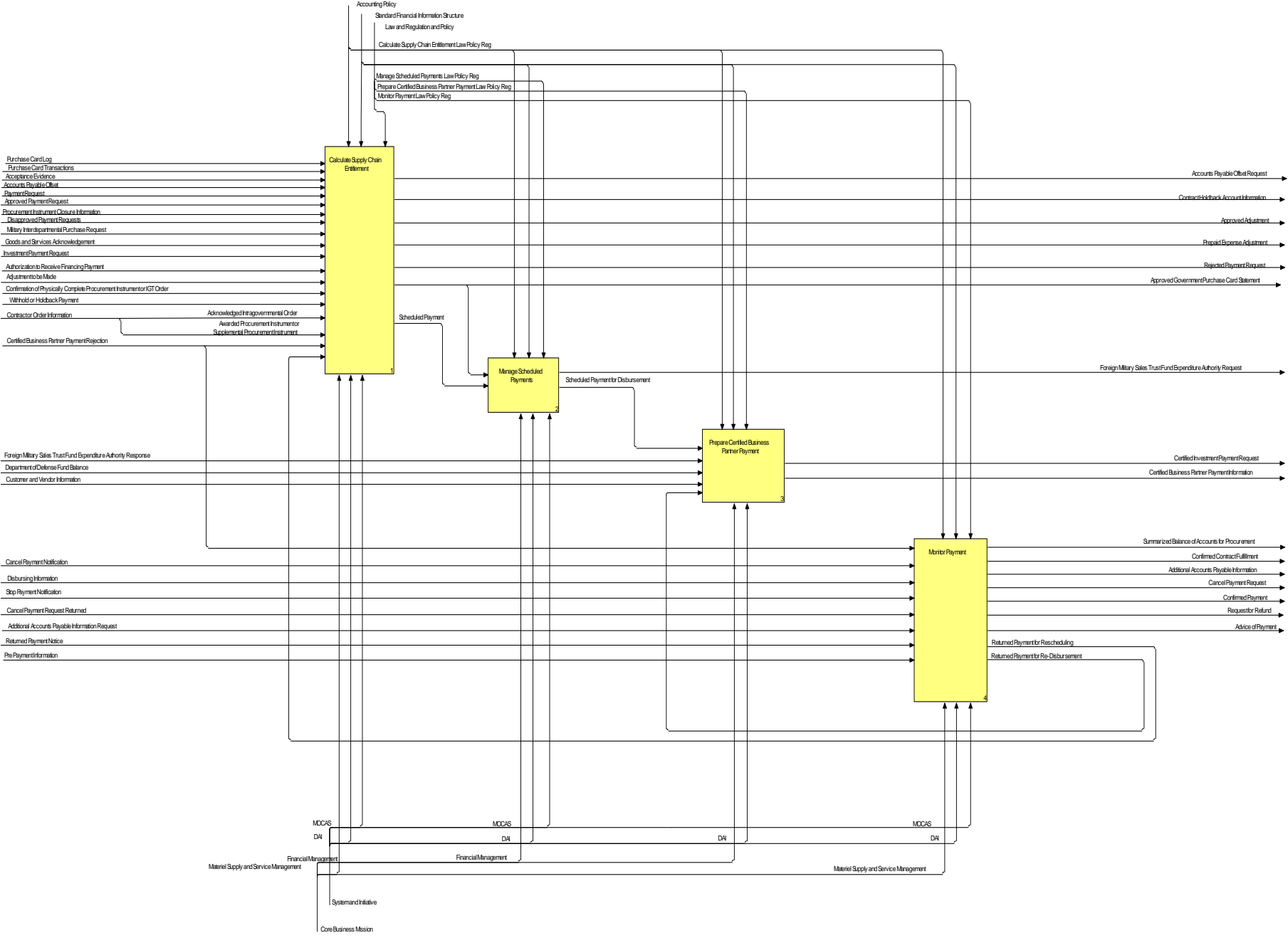

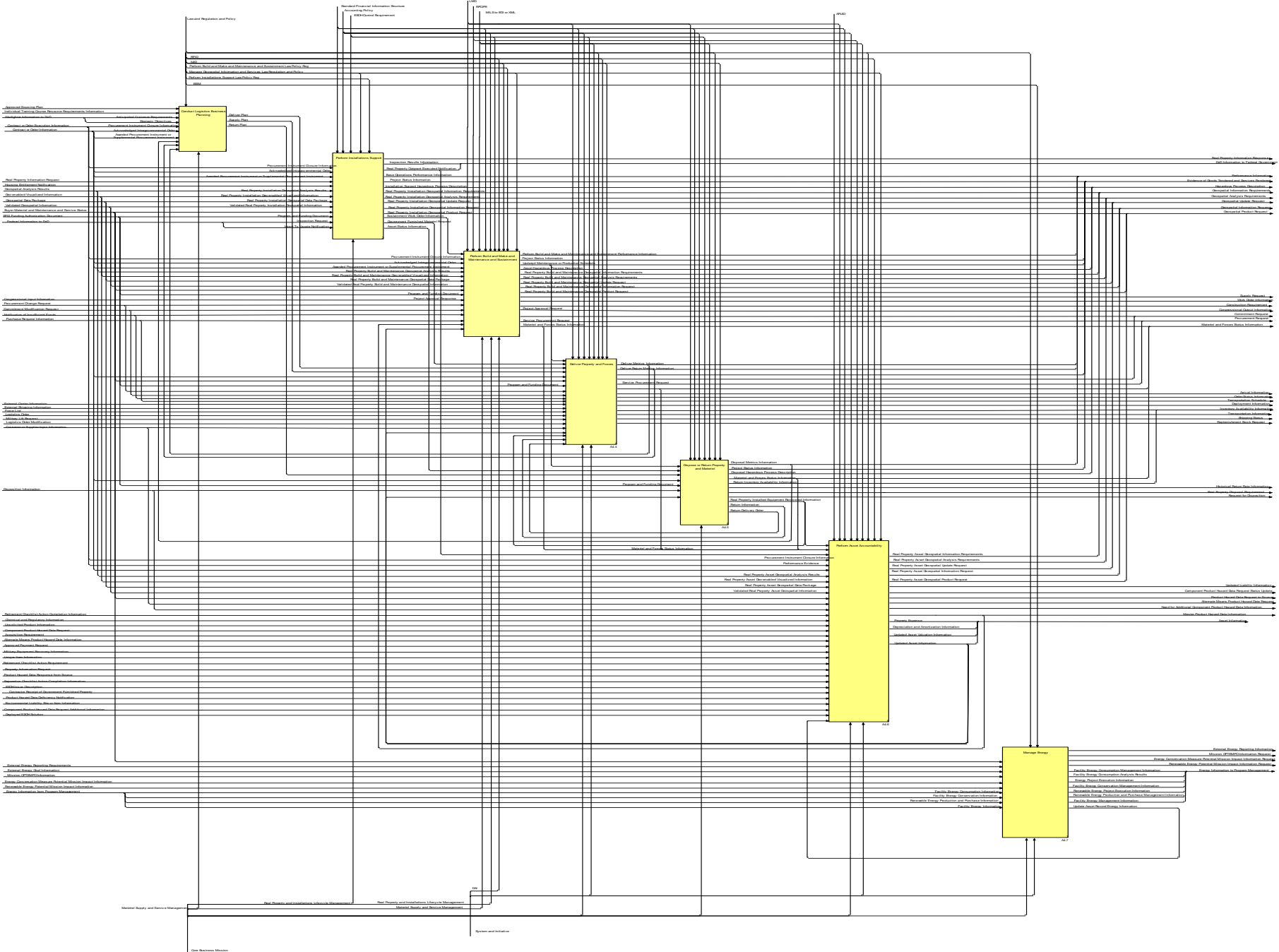

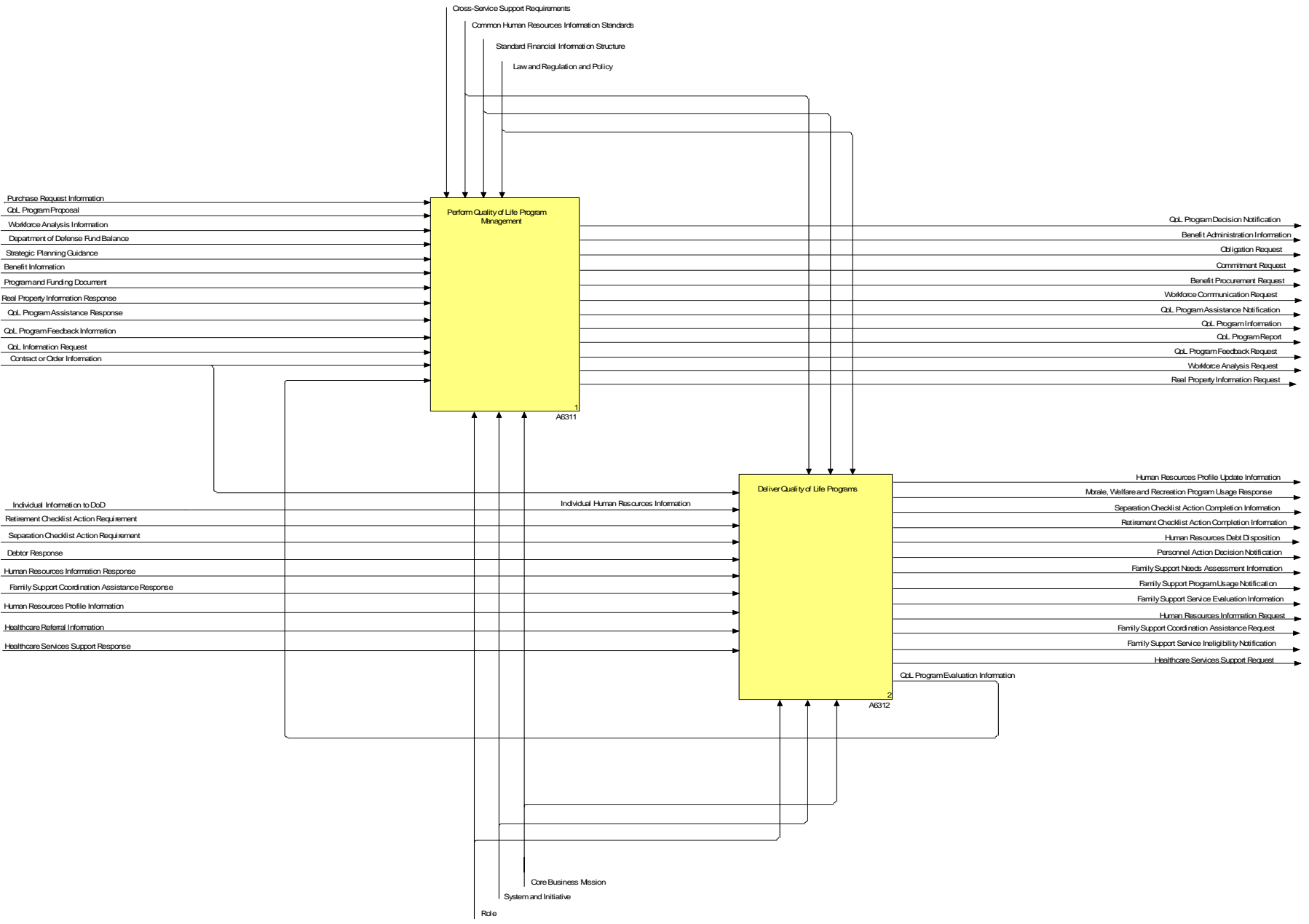

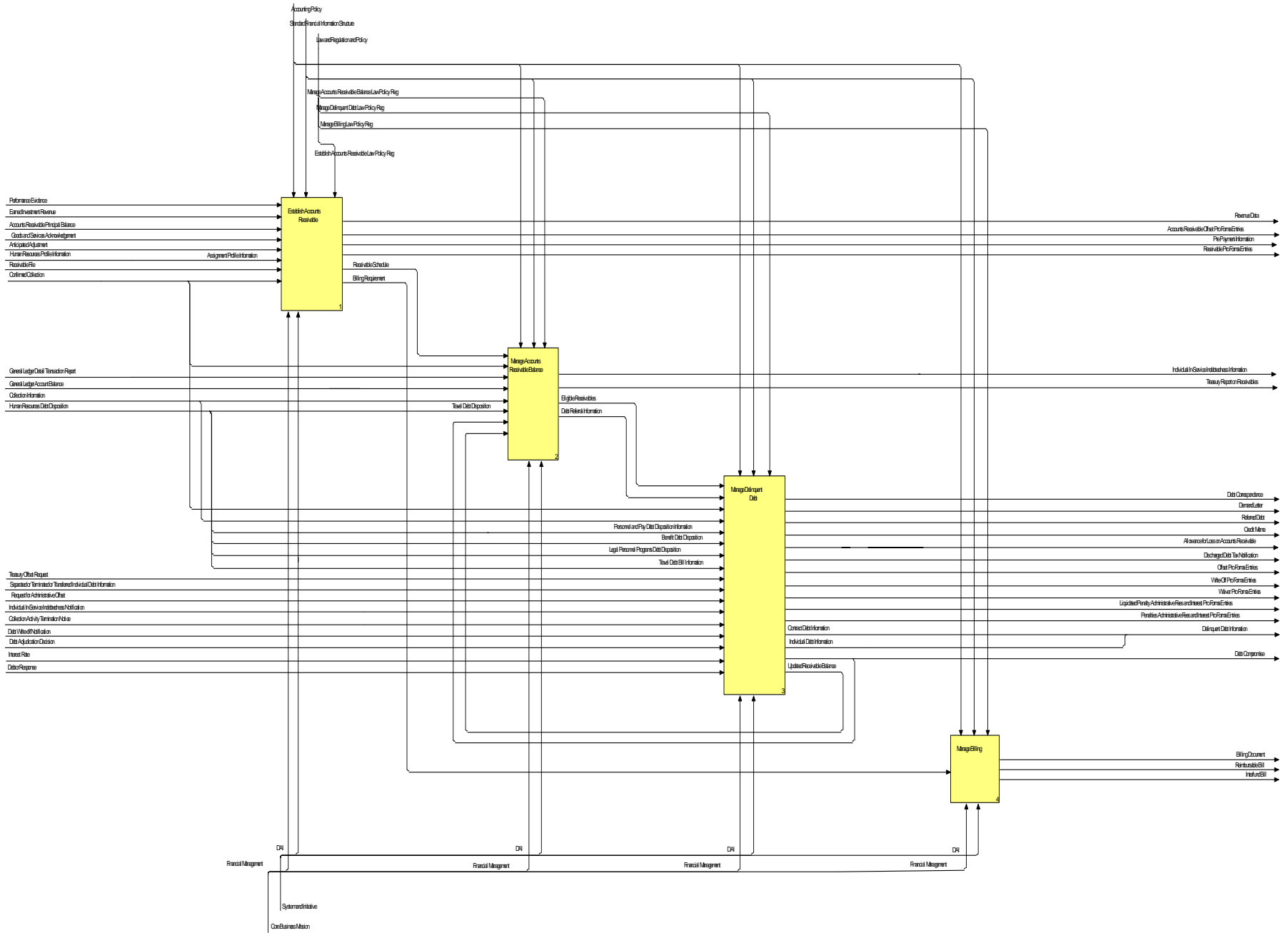

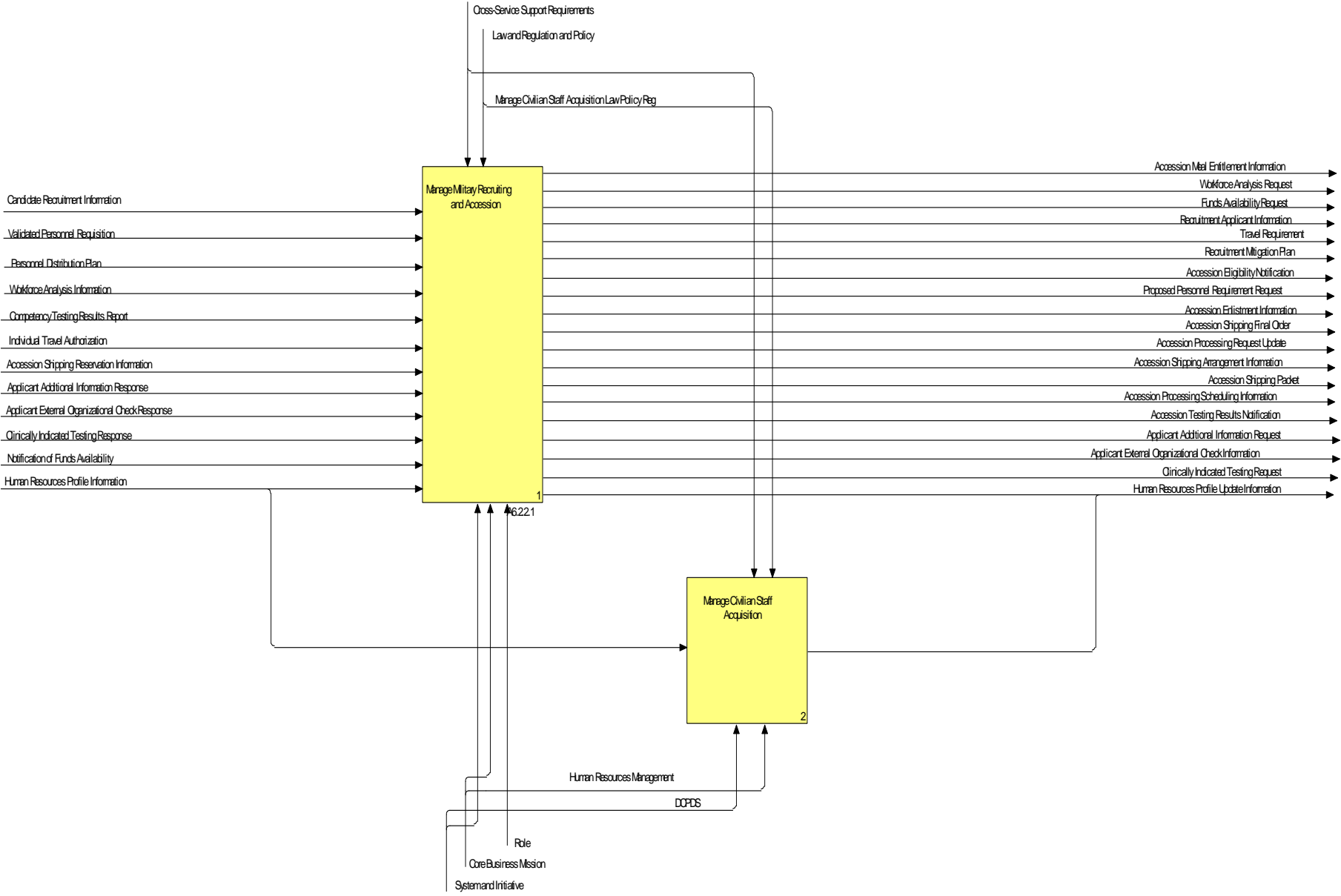

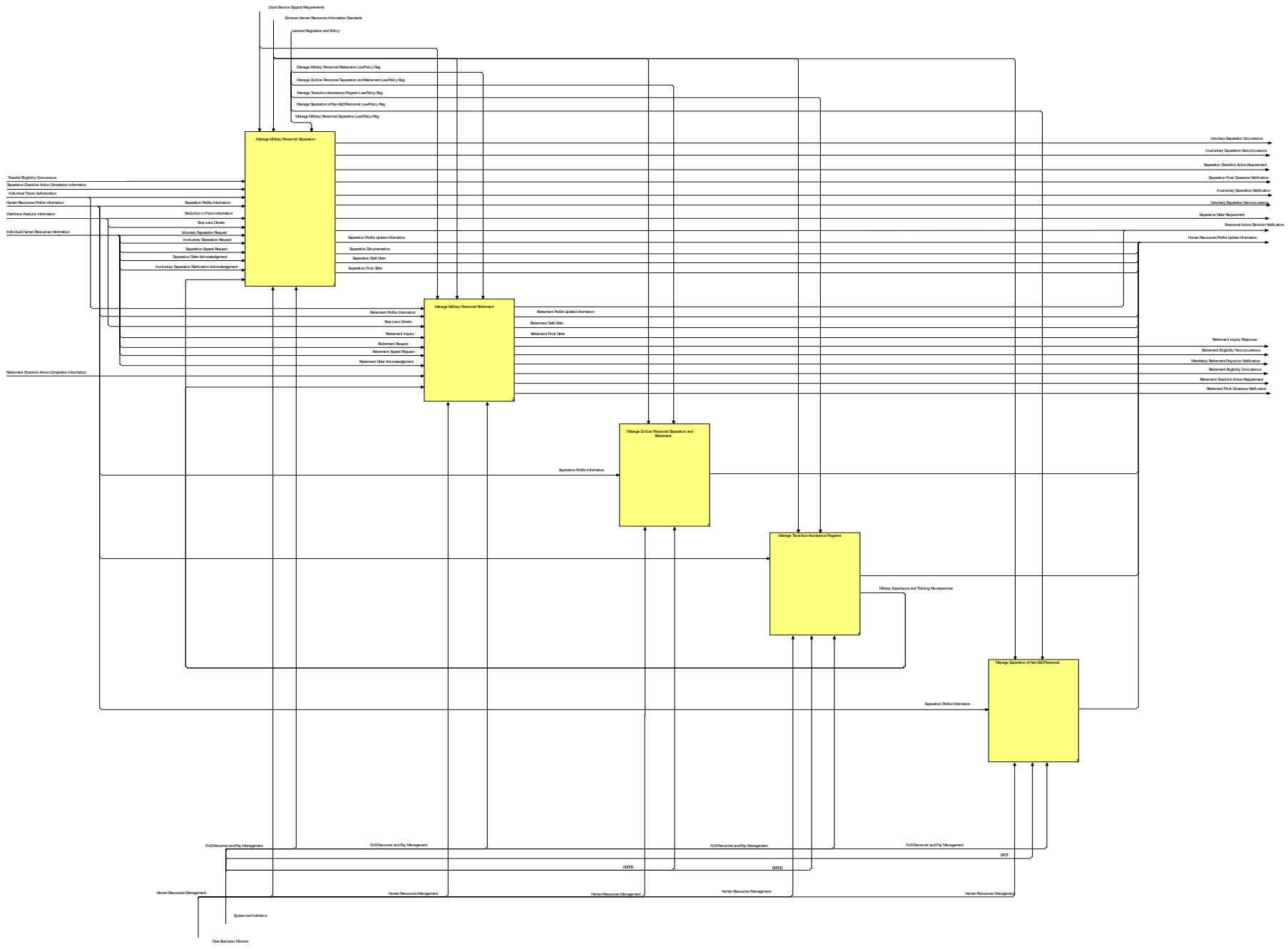

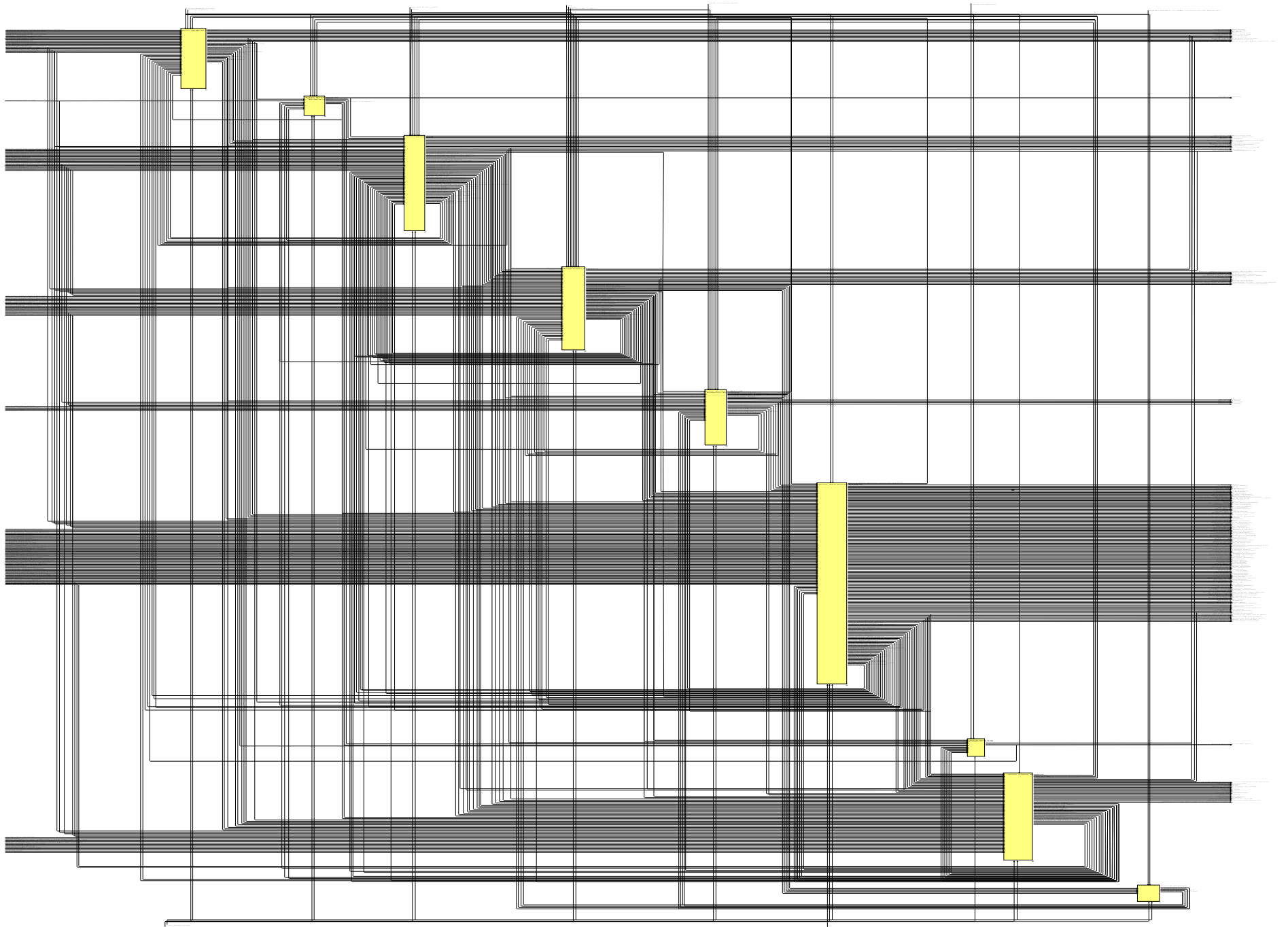

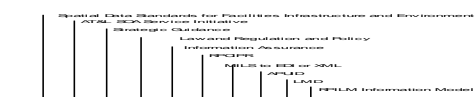

- Computer Science
- Artificial Intelligence
- Machine Learning
- Robotics
- Human-Computer Interaction
- Computer Graphics
- Computer Architecture
- Systems
- Operating Systems
- Networks
- Security
- Database Systems
- Software Engineering
- Programming Languages
- Formal Methods
- Theory of Computation
- Algorithms
- Mathematics
- Statistics
- Physics
- Chemistry
- Biology
- Environmental Science
- Earth and Planetary Science
- Interdisciplinary Research
- Public Policy
- Law
- Business
- Engineering
- Design
- Arts
- Humanities
- Social Sciences

- Department of Computer Science
- Department of Mathematics
- Department of Physics
- Department of Chemistry
- Department of Biology
- Department of Earth and Planetary Science
- Department of Environmental Science
- Department of Public Policy
- Department of Law
- Department of Business
- Department of Engineering
- Department of Design
- Department of Arts
- Department of Humanities
- Department of Social Sciences

- Department of Computer Science
- Department of Mathematics
- Department of Physics
- Department of Chemistry
- Department of Biology
- Department of Earth and Planetary Science
- Department of Environmental Science
- Department of Public Policy
- Department of Law
- Department of Business
- Department of Engineering
- Department of Design
- Department of Arts
- Department of Humanities
- Department of Social Sciences

This document is a preliminary map of the Department of Computer Science's research interests. It is not intended to be a comprehensive list of all research areas, but rather a high-level overview of the department's research focus. The map is subject to change as the department's research interests evolve over time. For more information, please contact the department's research director.

Research and Innovation
Core Business Division

Research and Innovation
Core Business Division

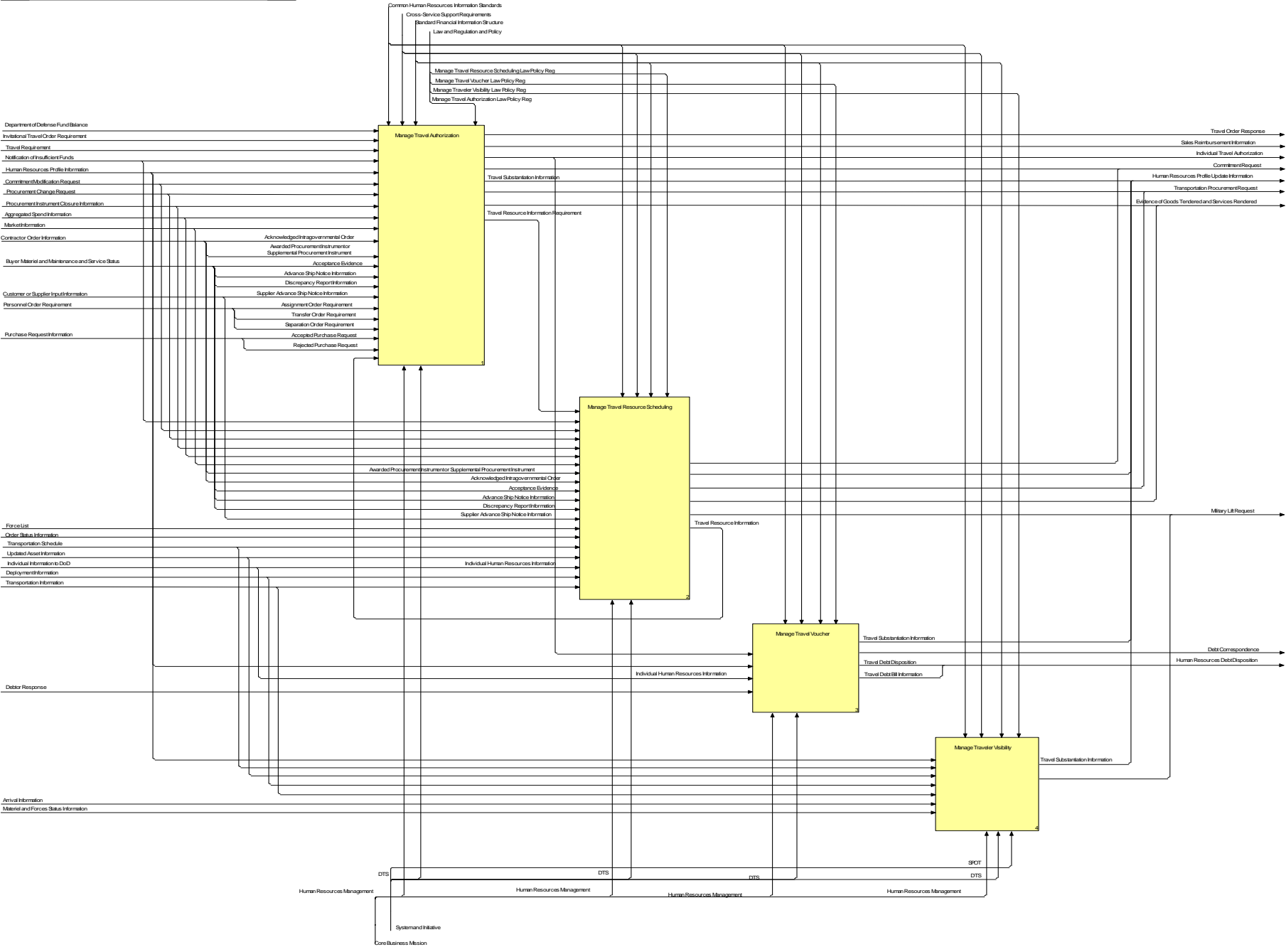

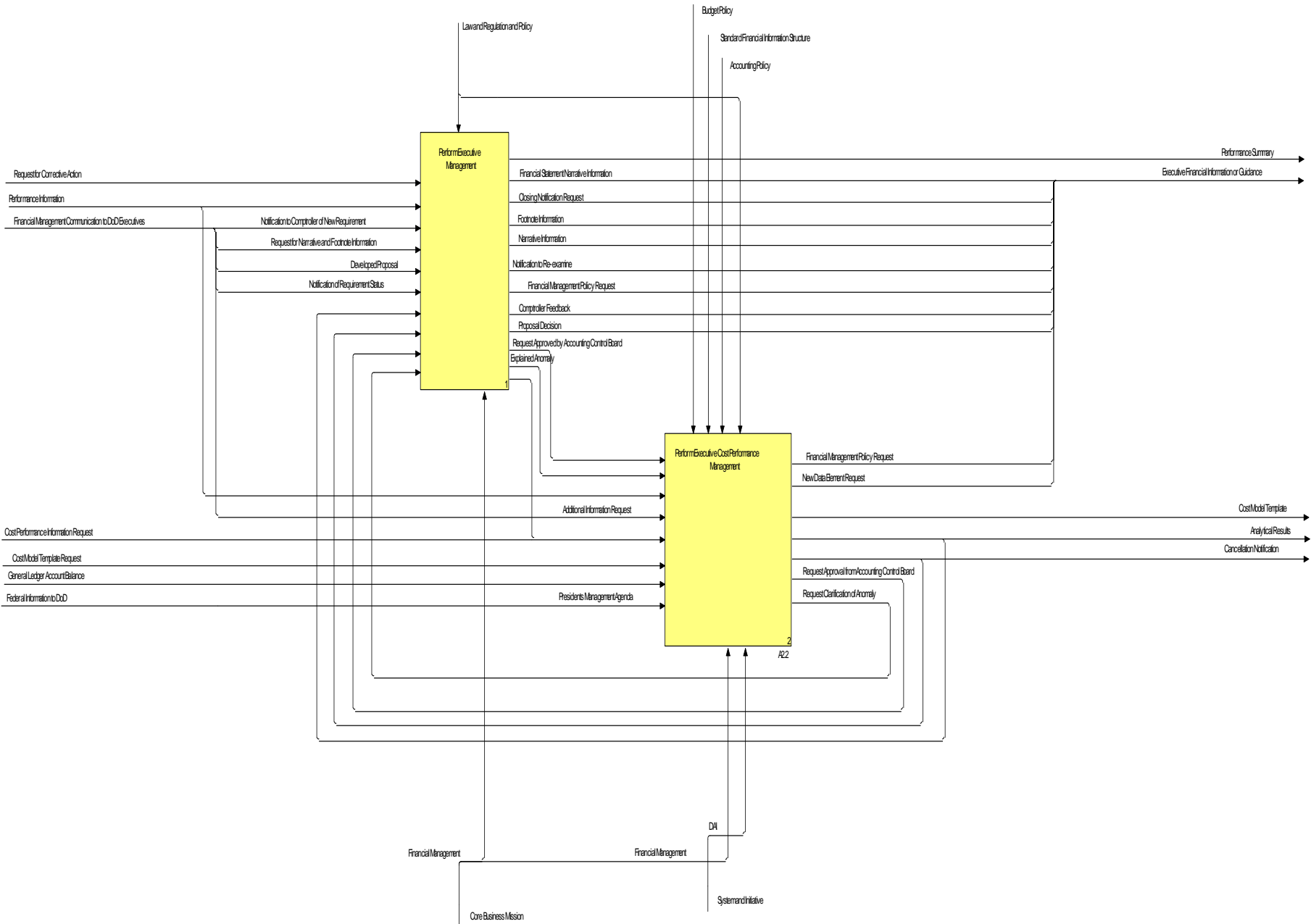

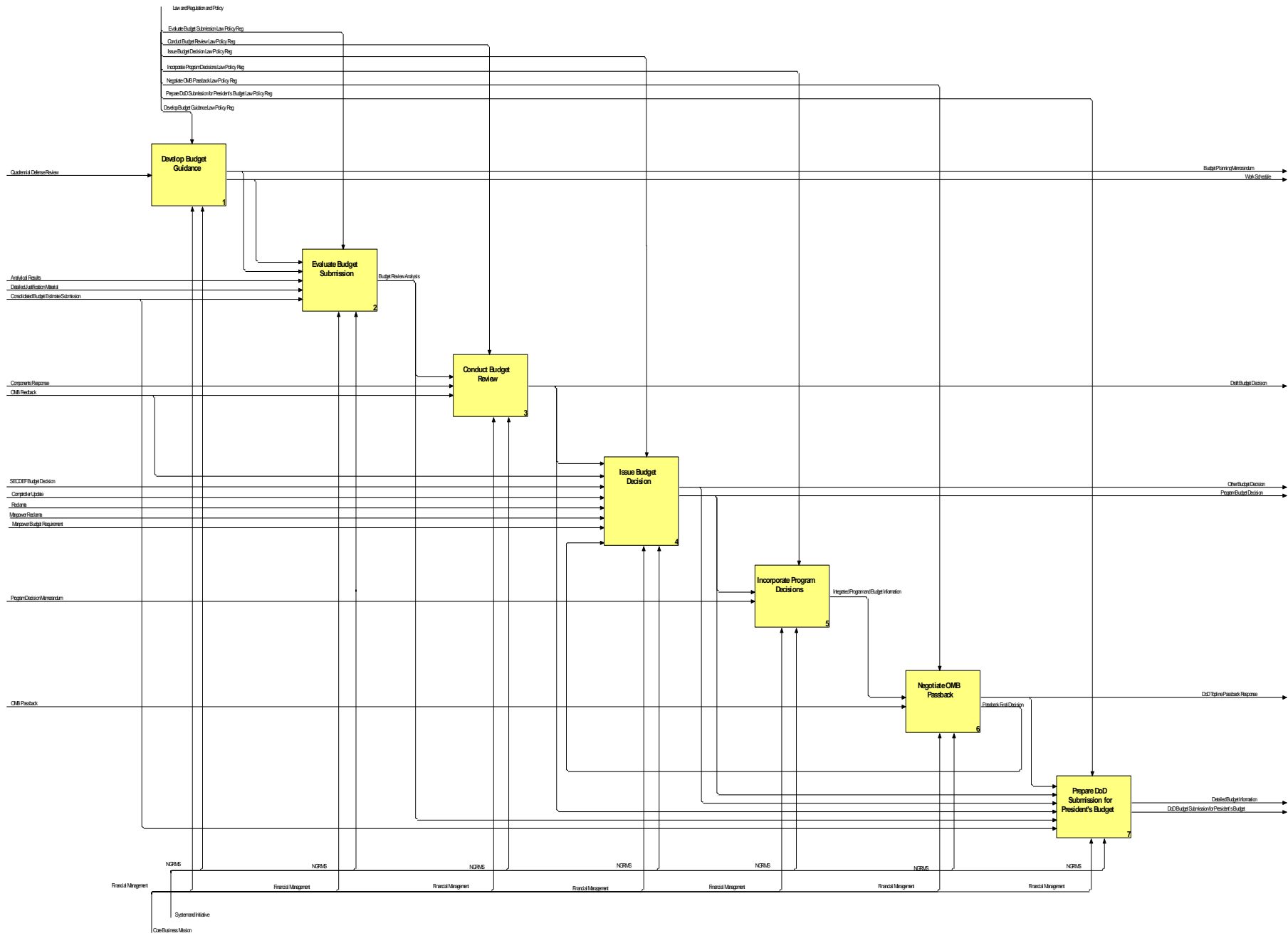

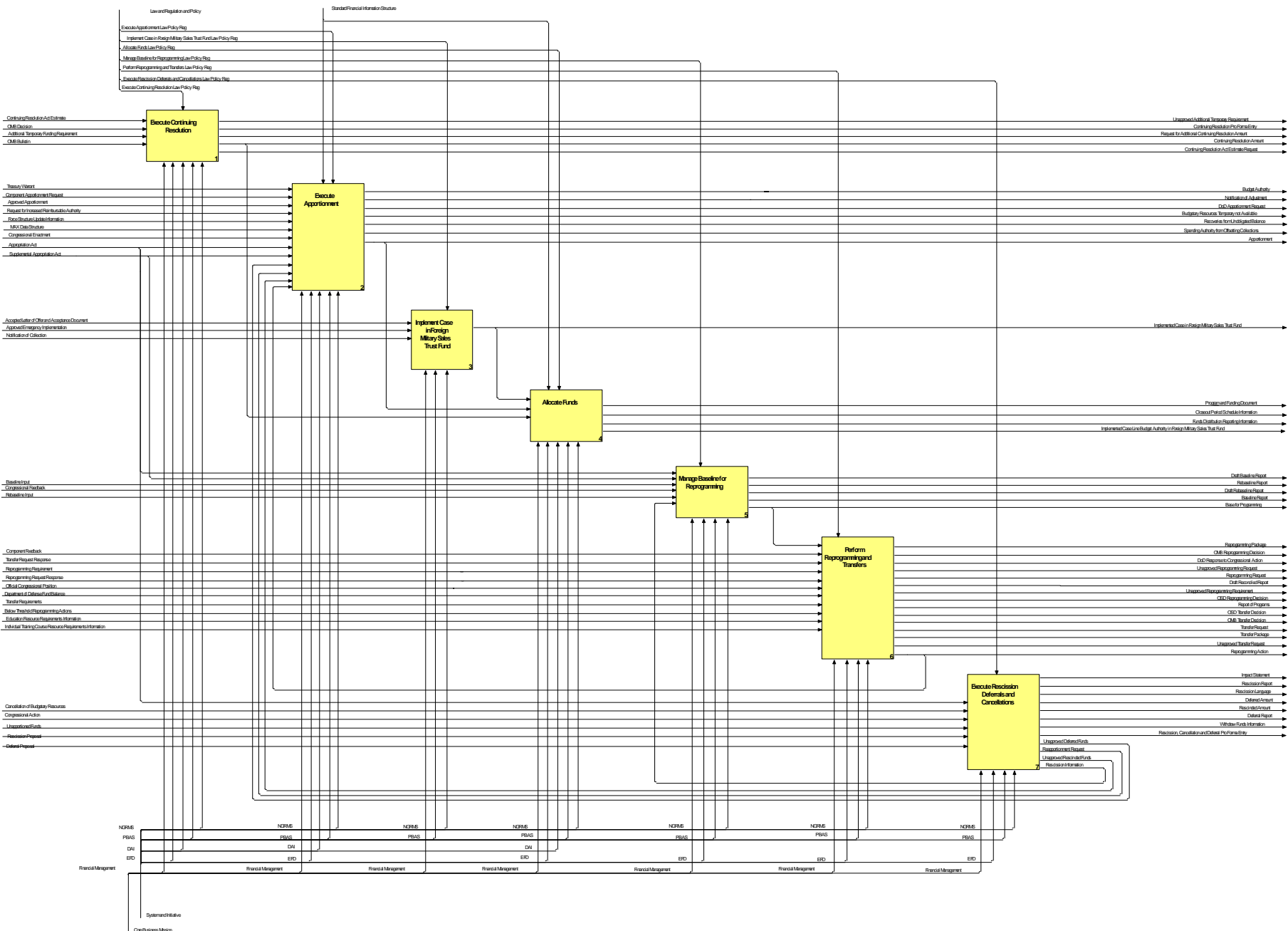



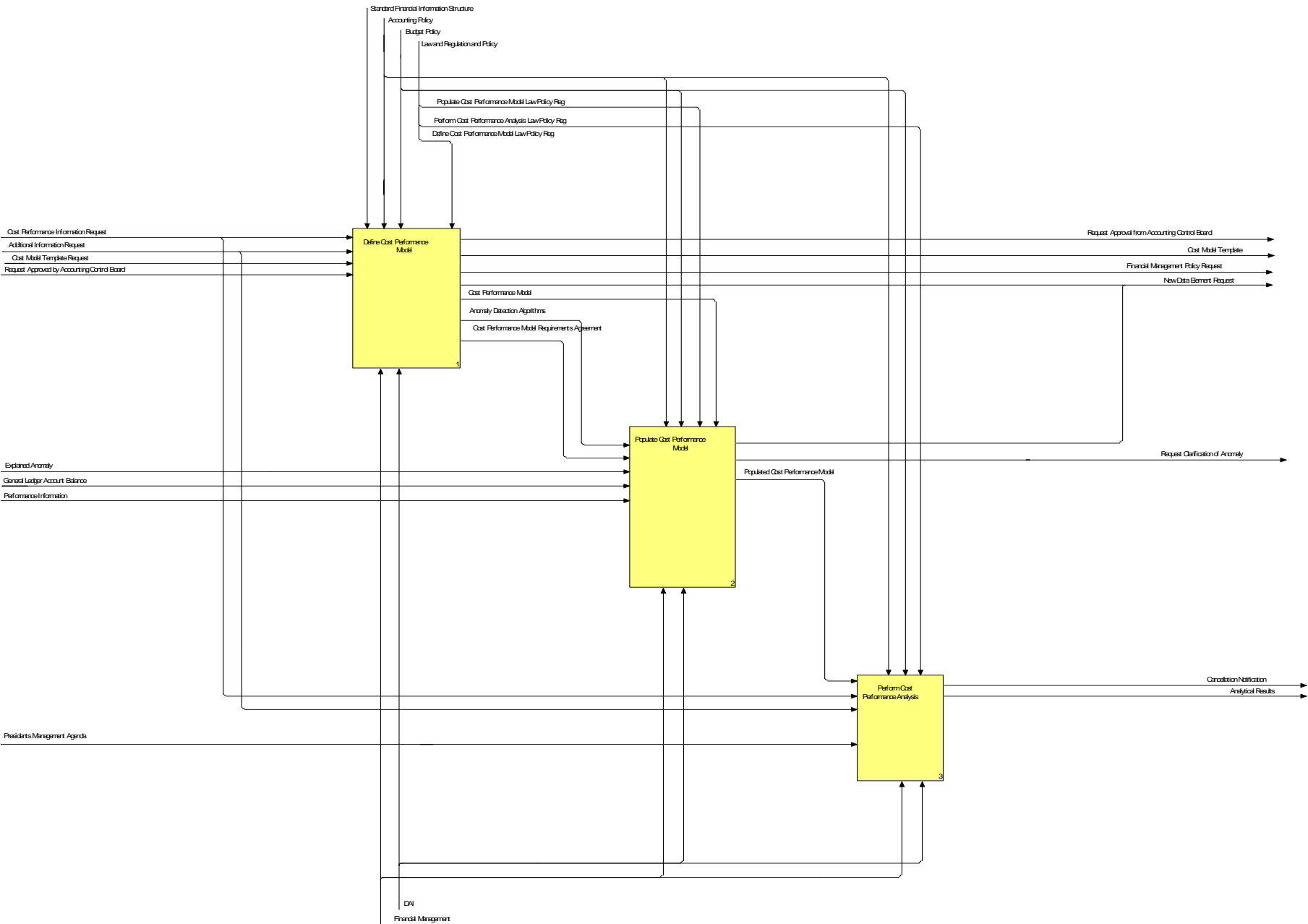

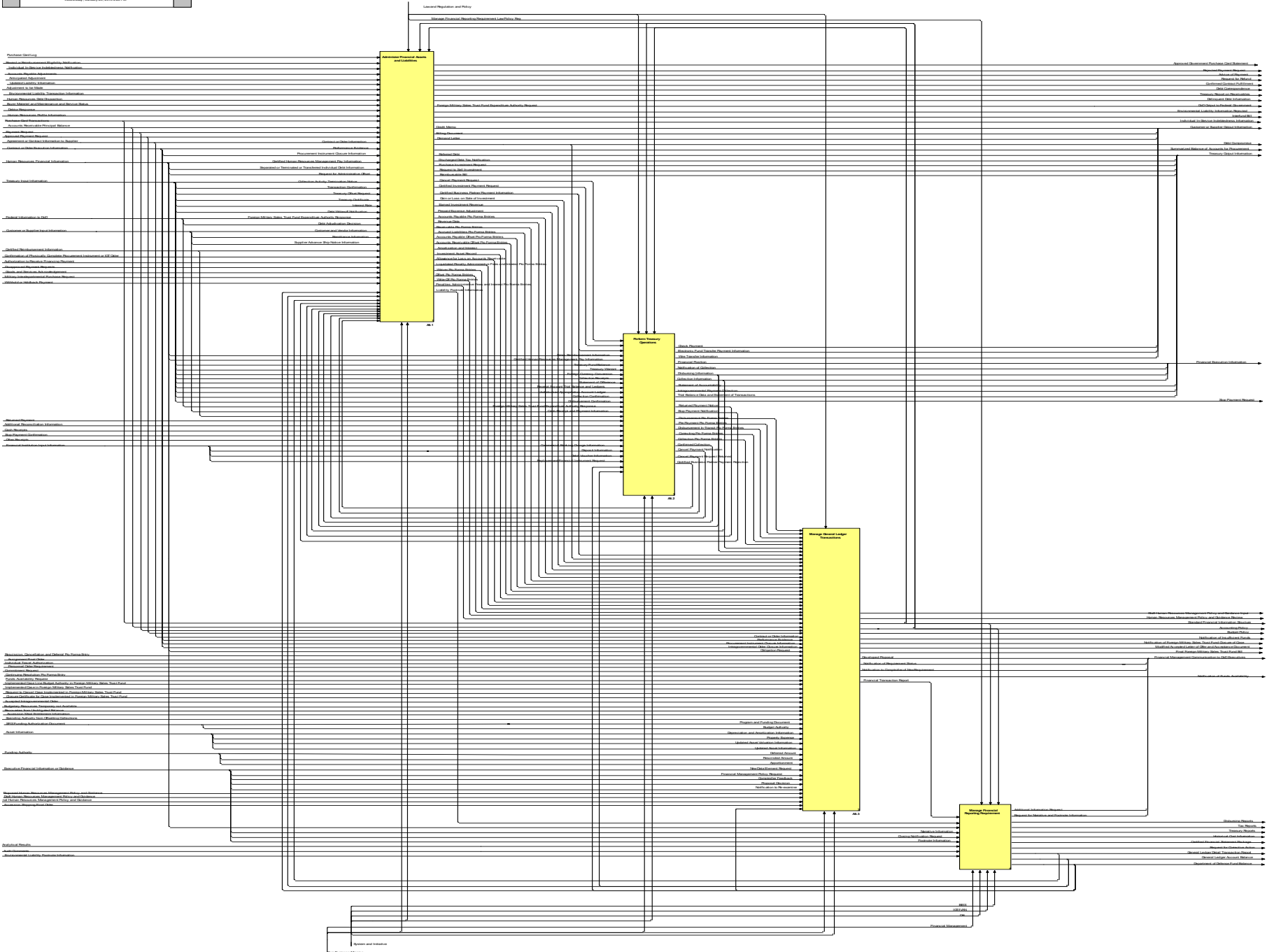

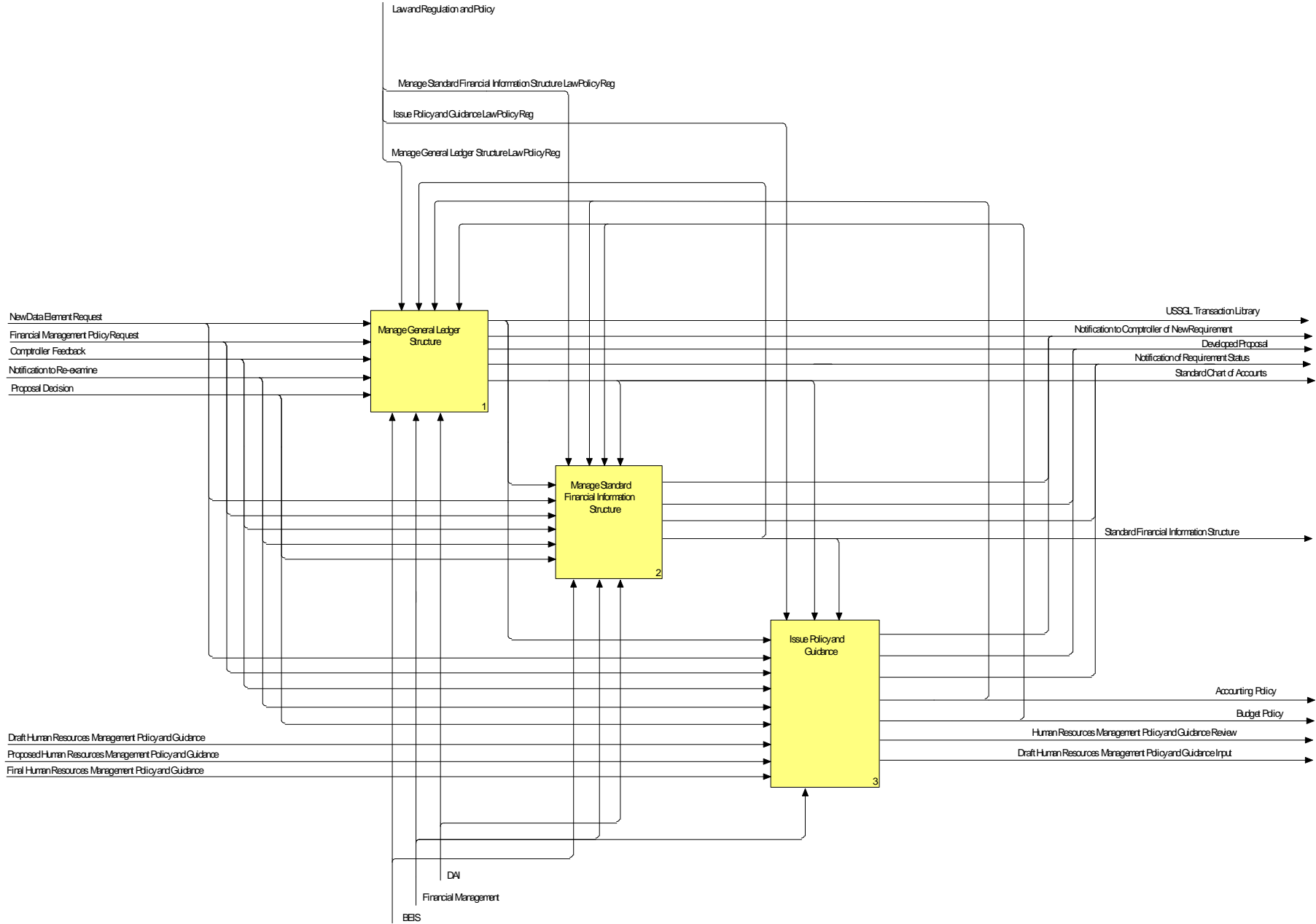

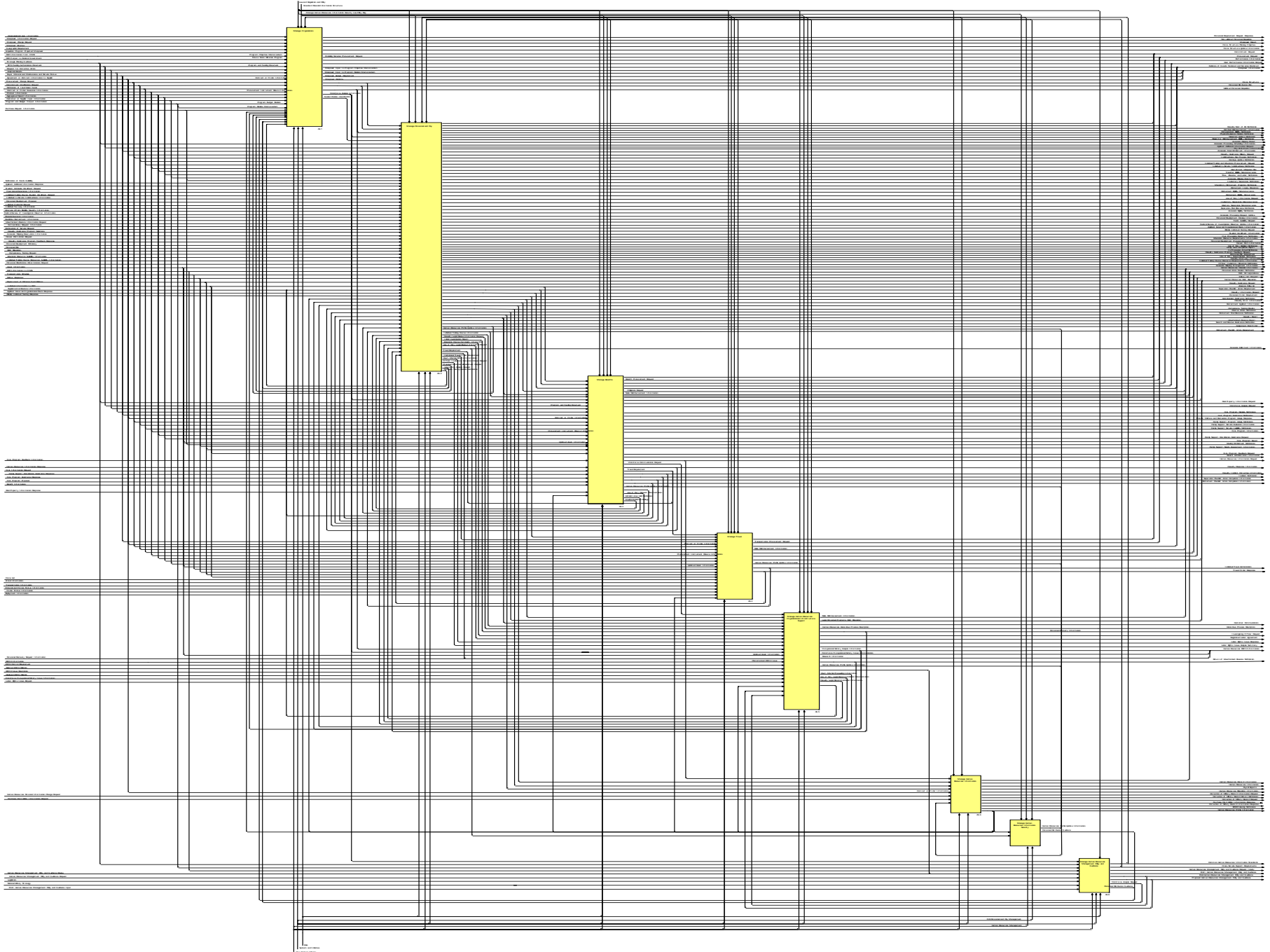

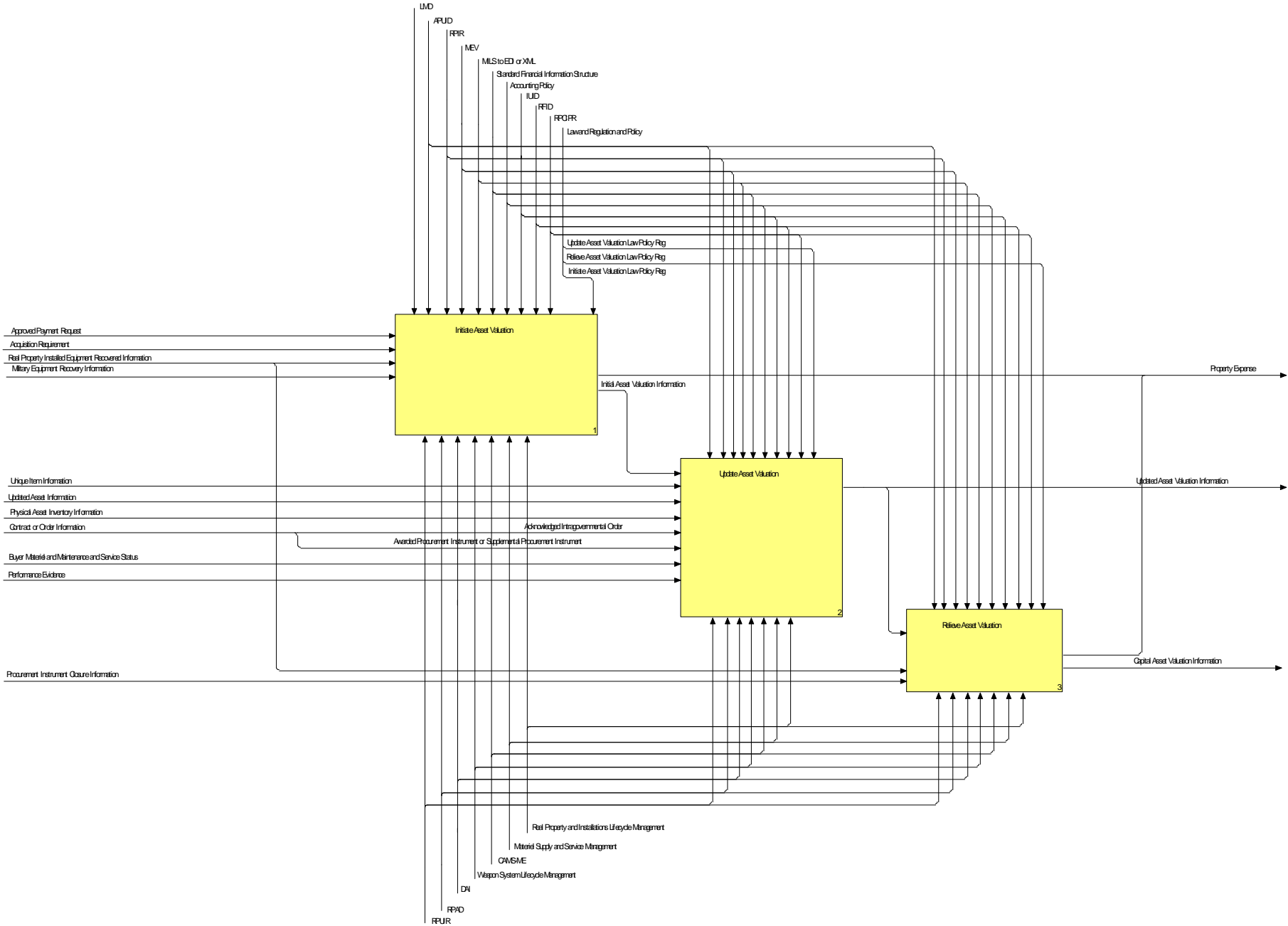

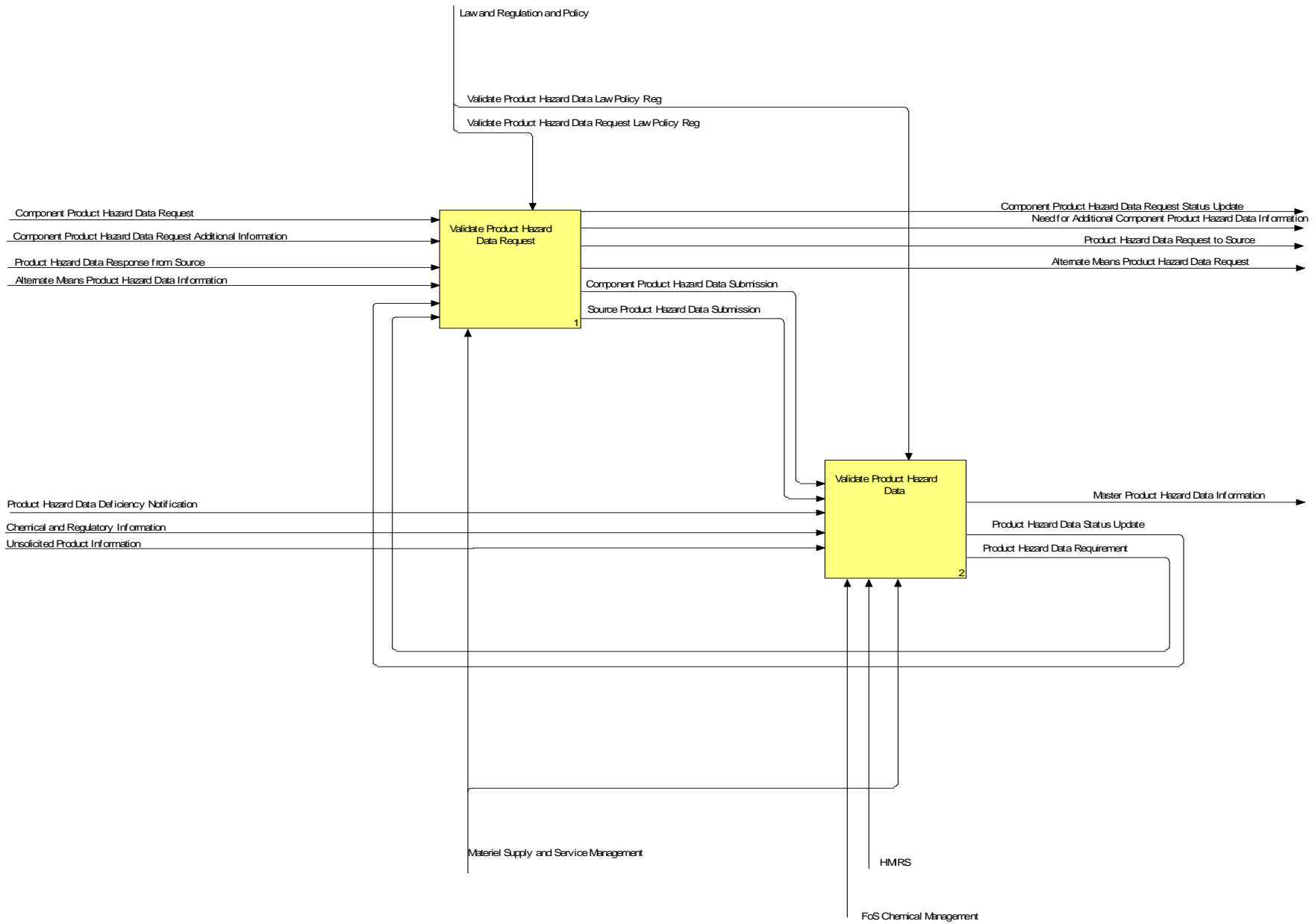

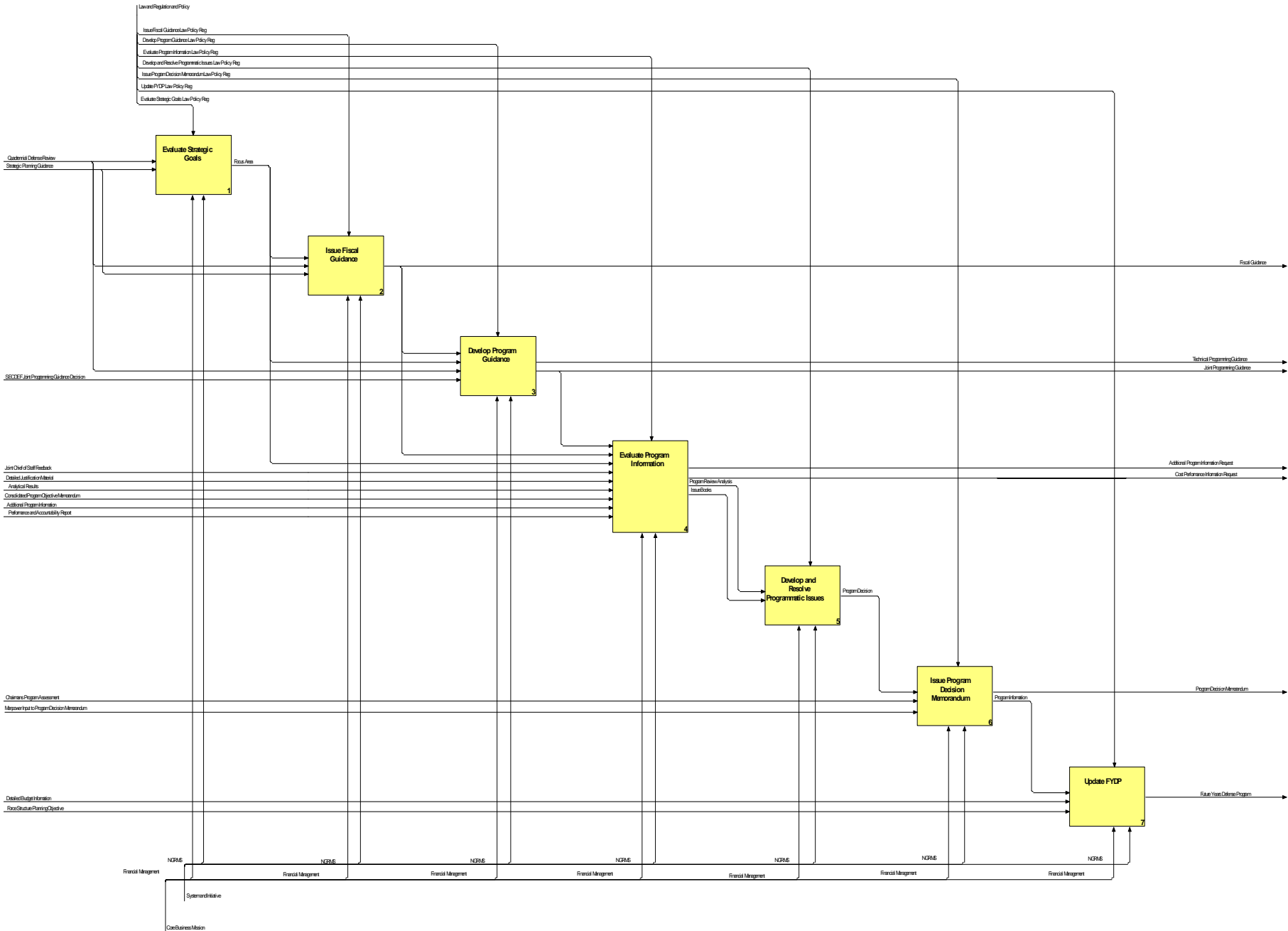

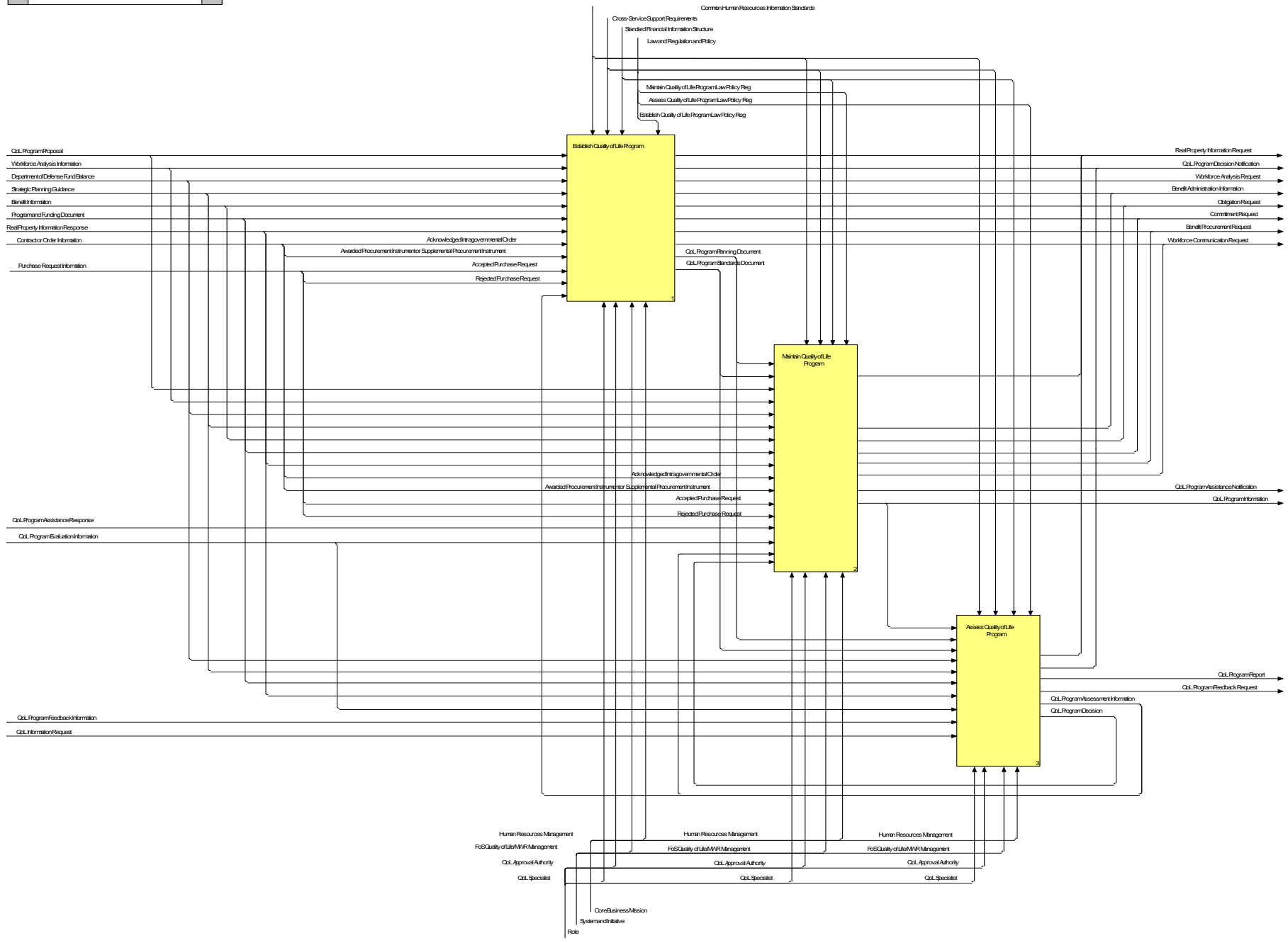

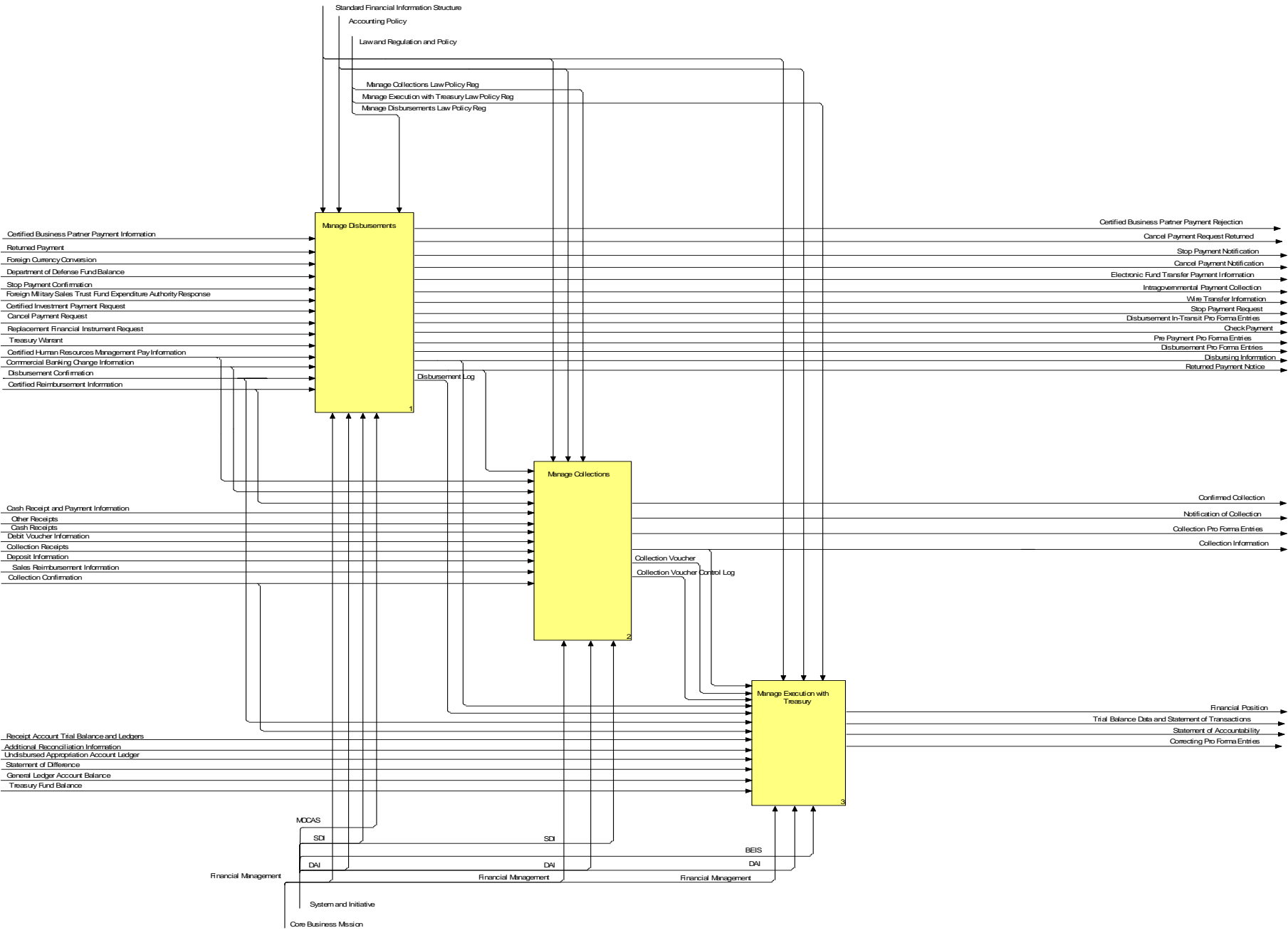

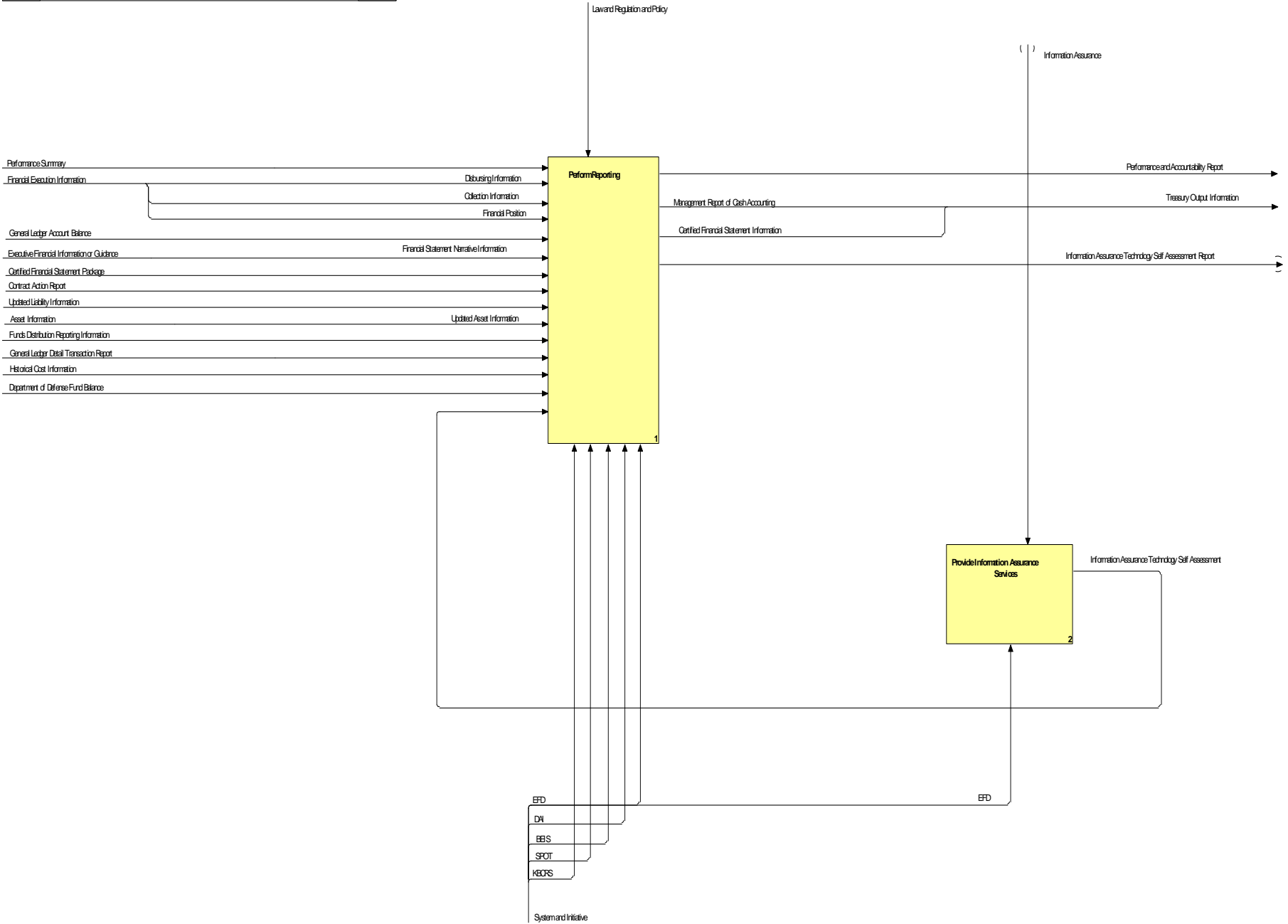

8.0 Accept Goods and Services (OV-6c Business Process)

System Architect
Tuesday, February 21, 2012 11:22 AM

Model to be deleted following E2E Integration.

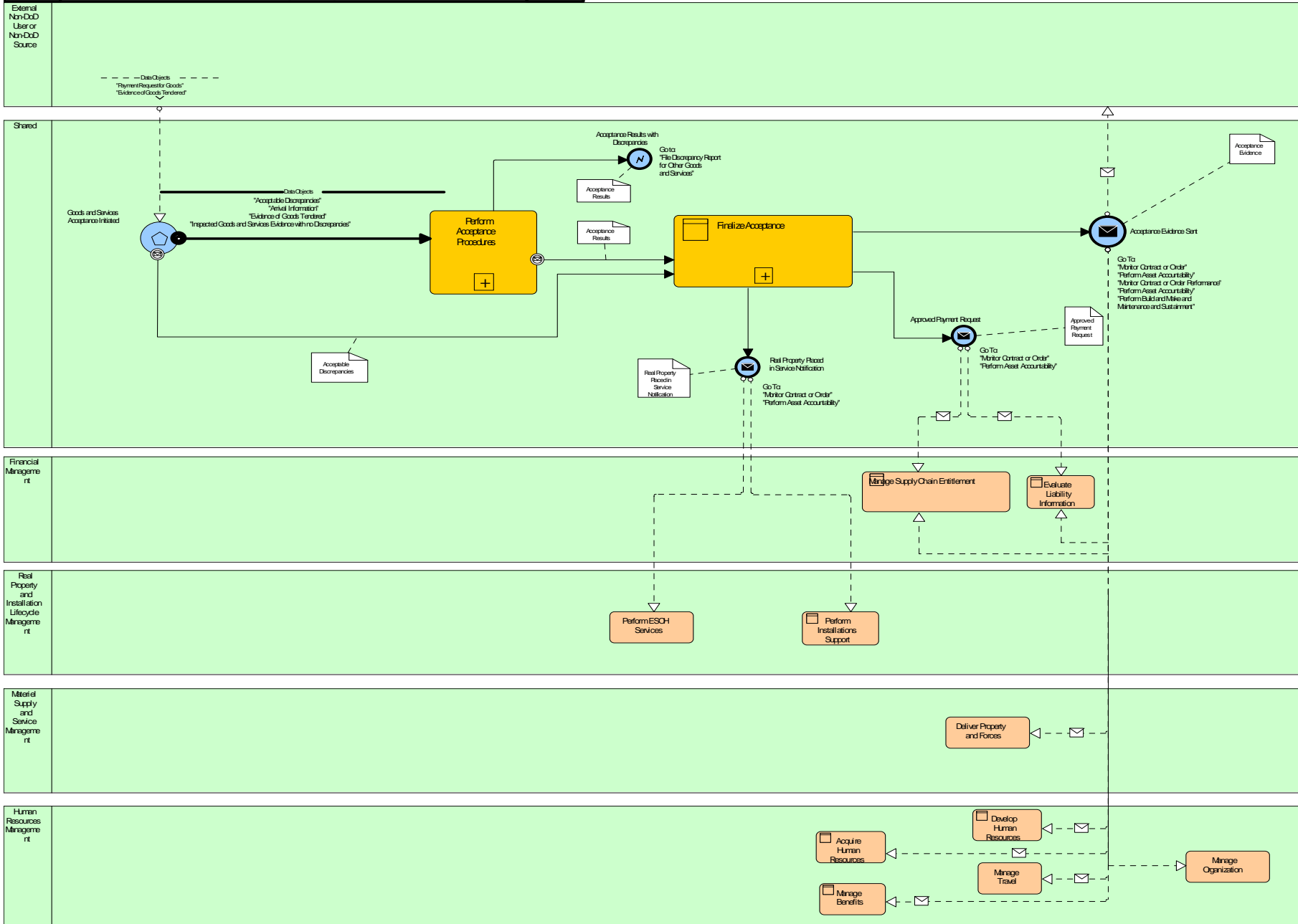

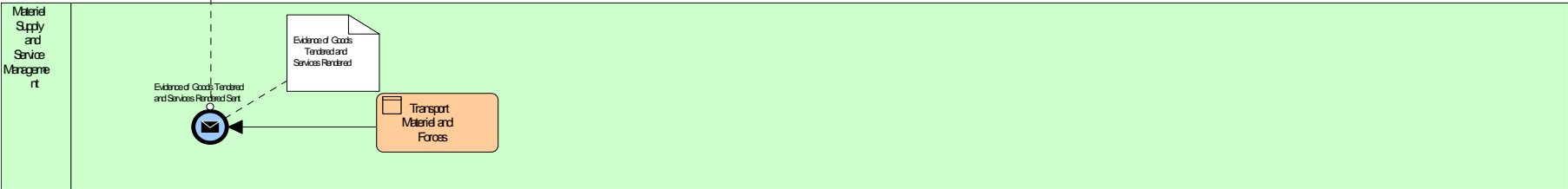
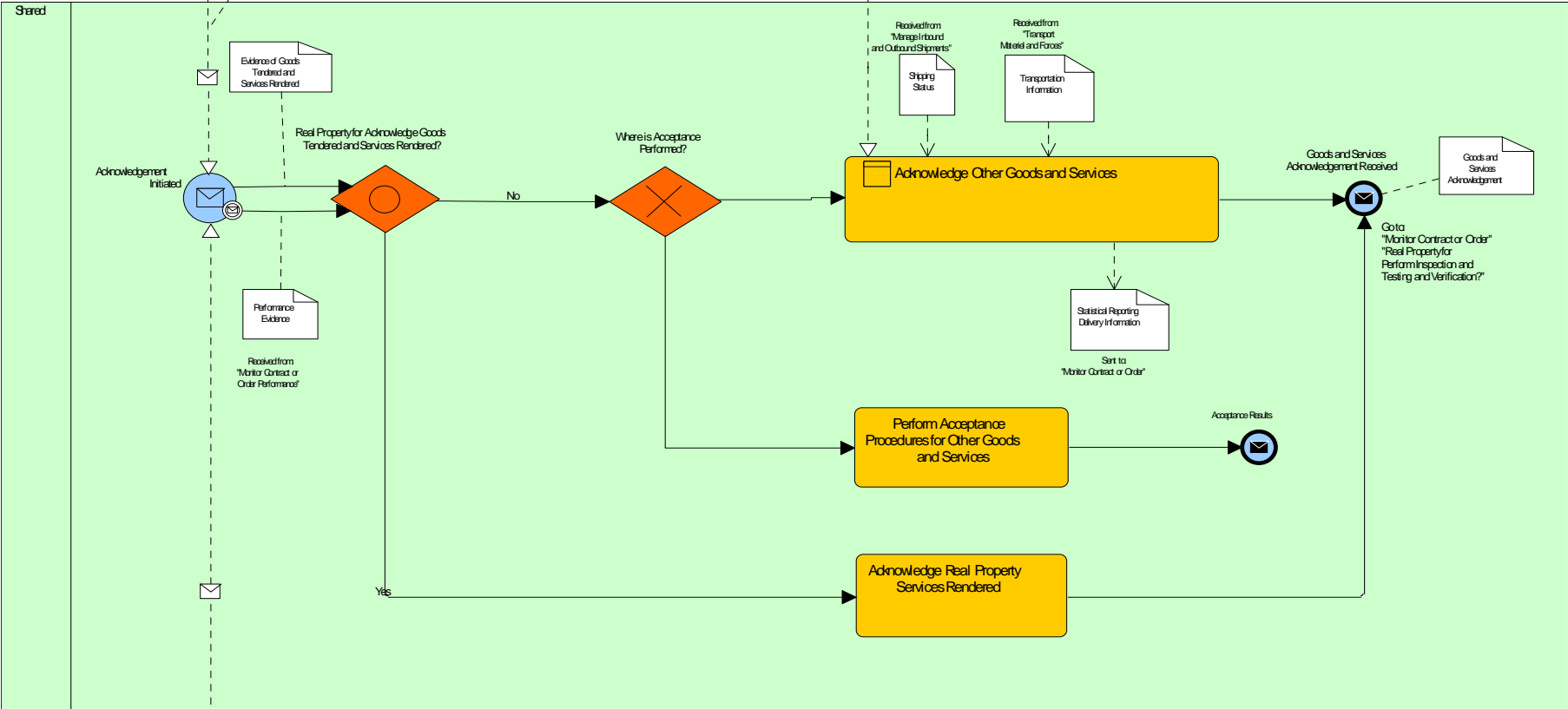
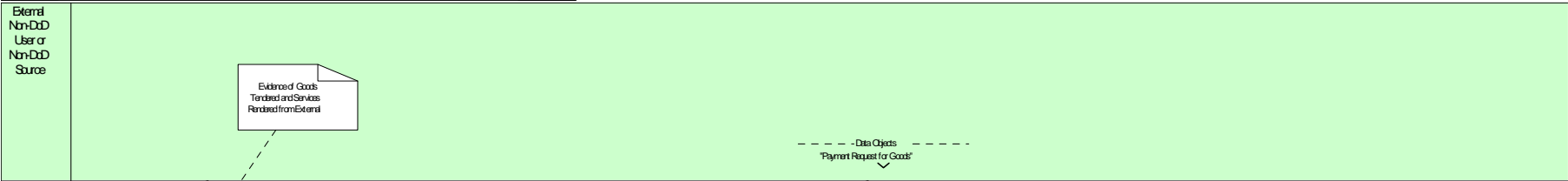

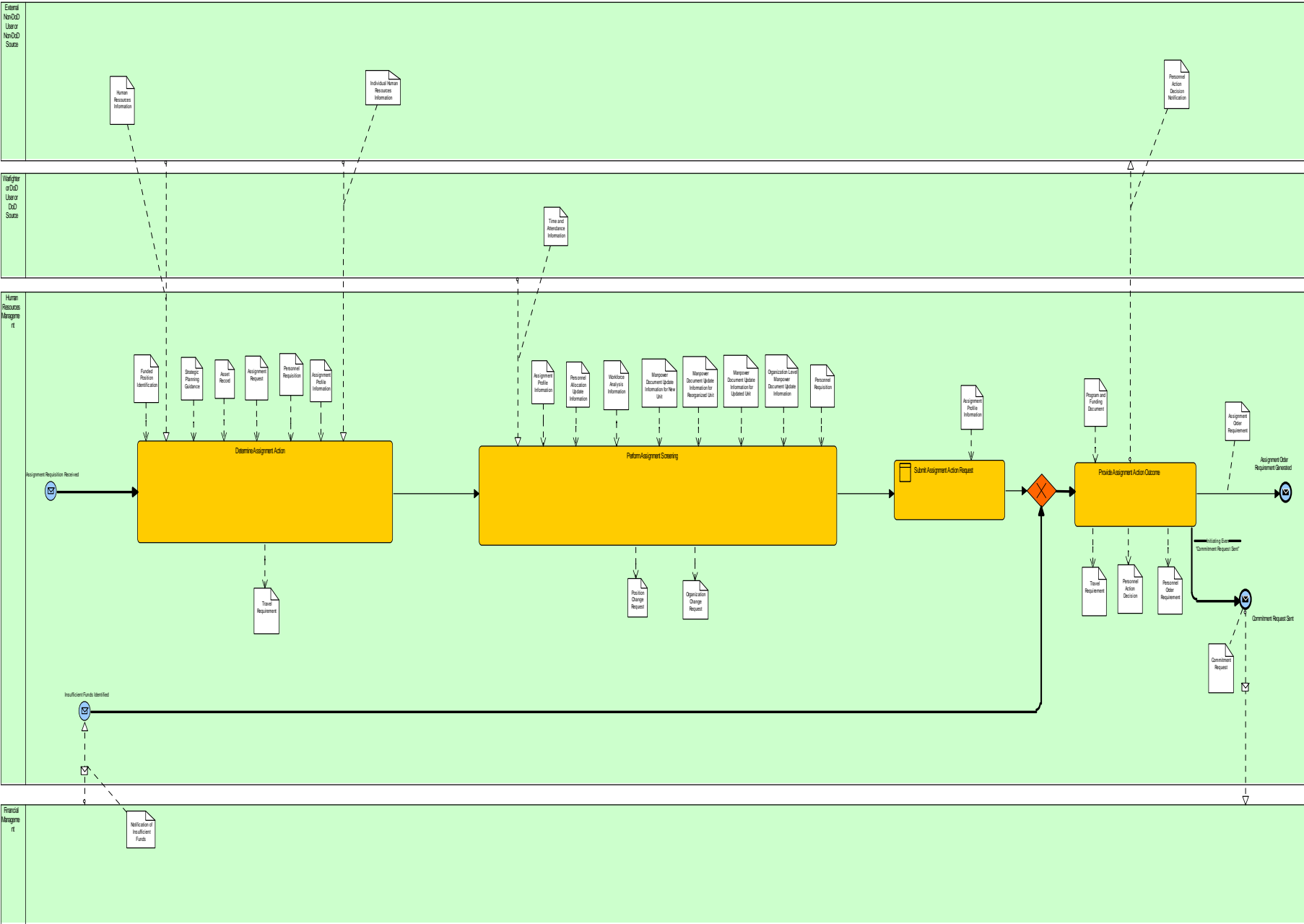

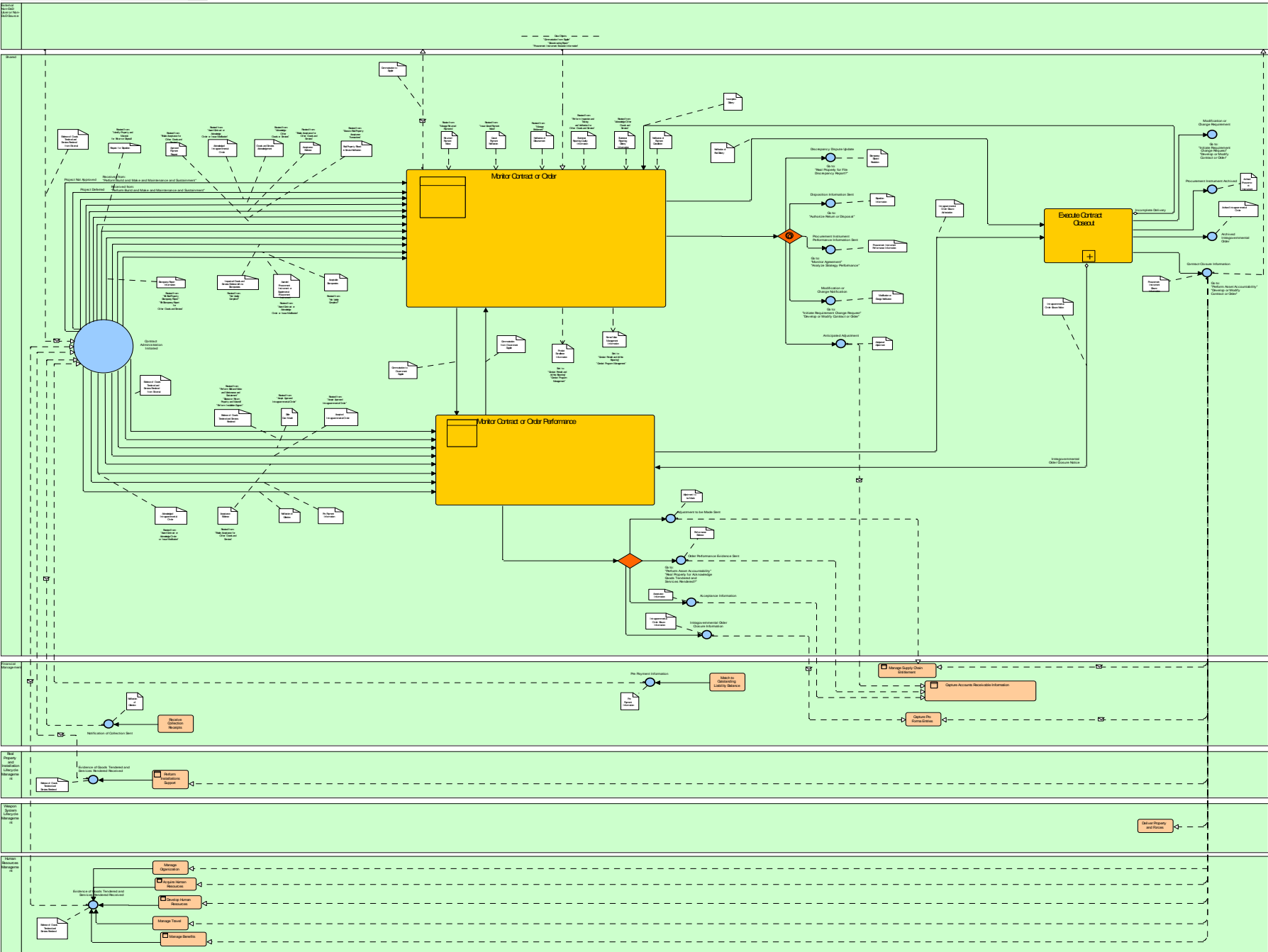

Human Resources Management

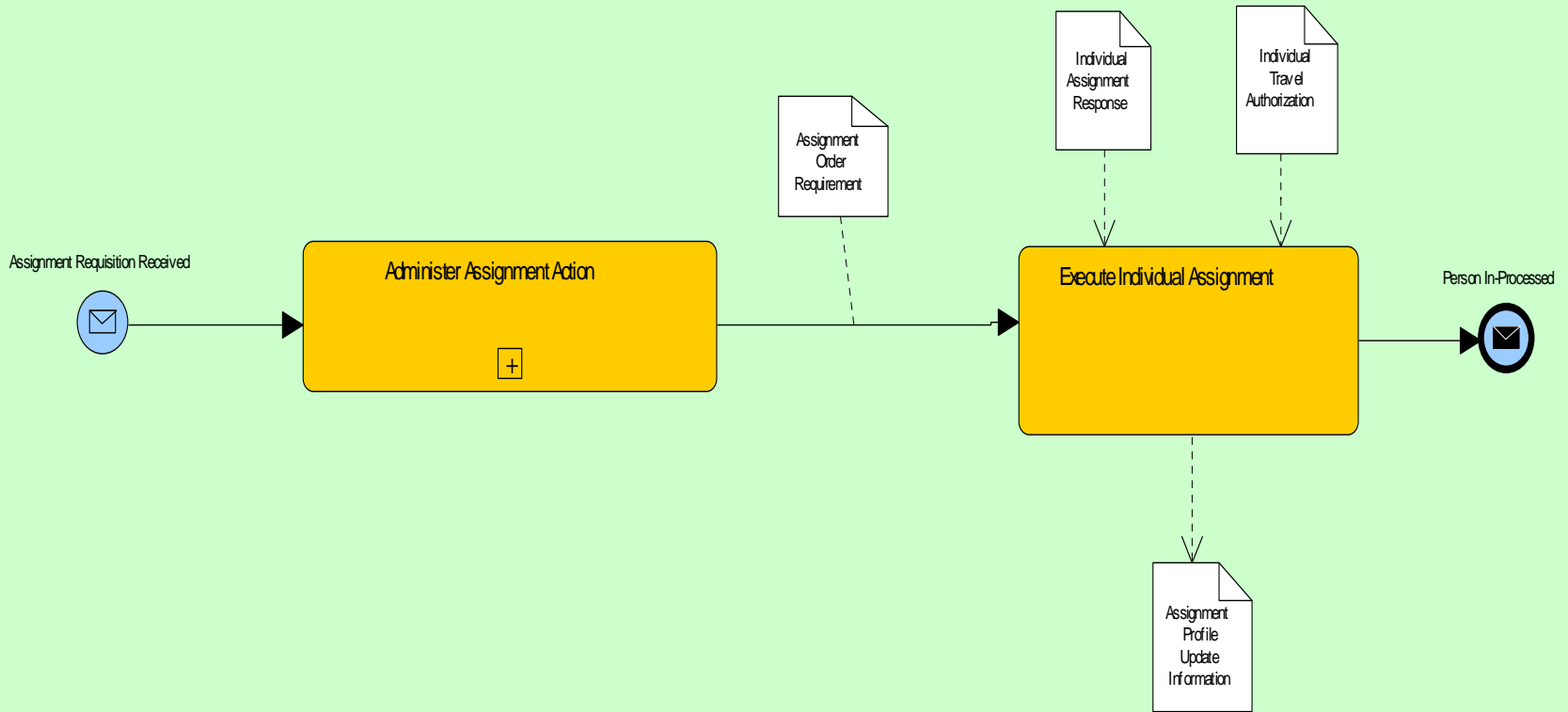

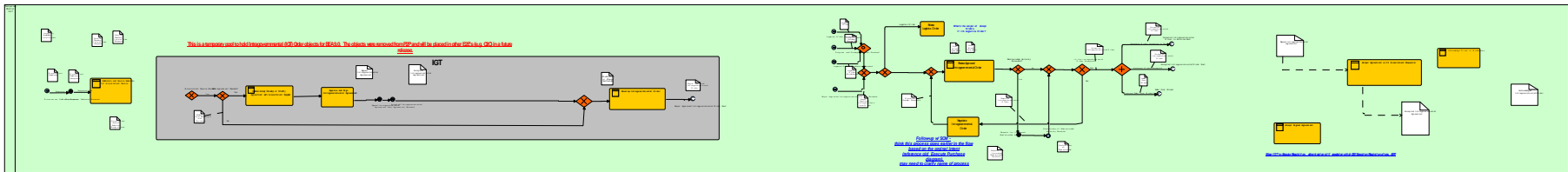
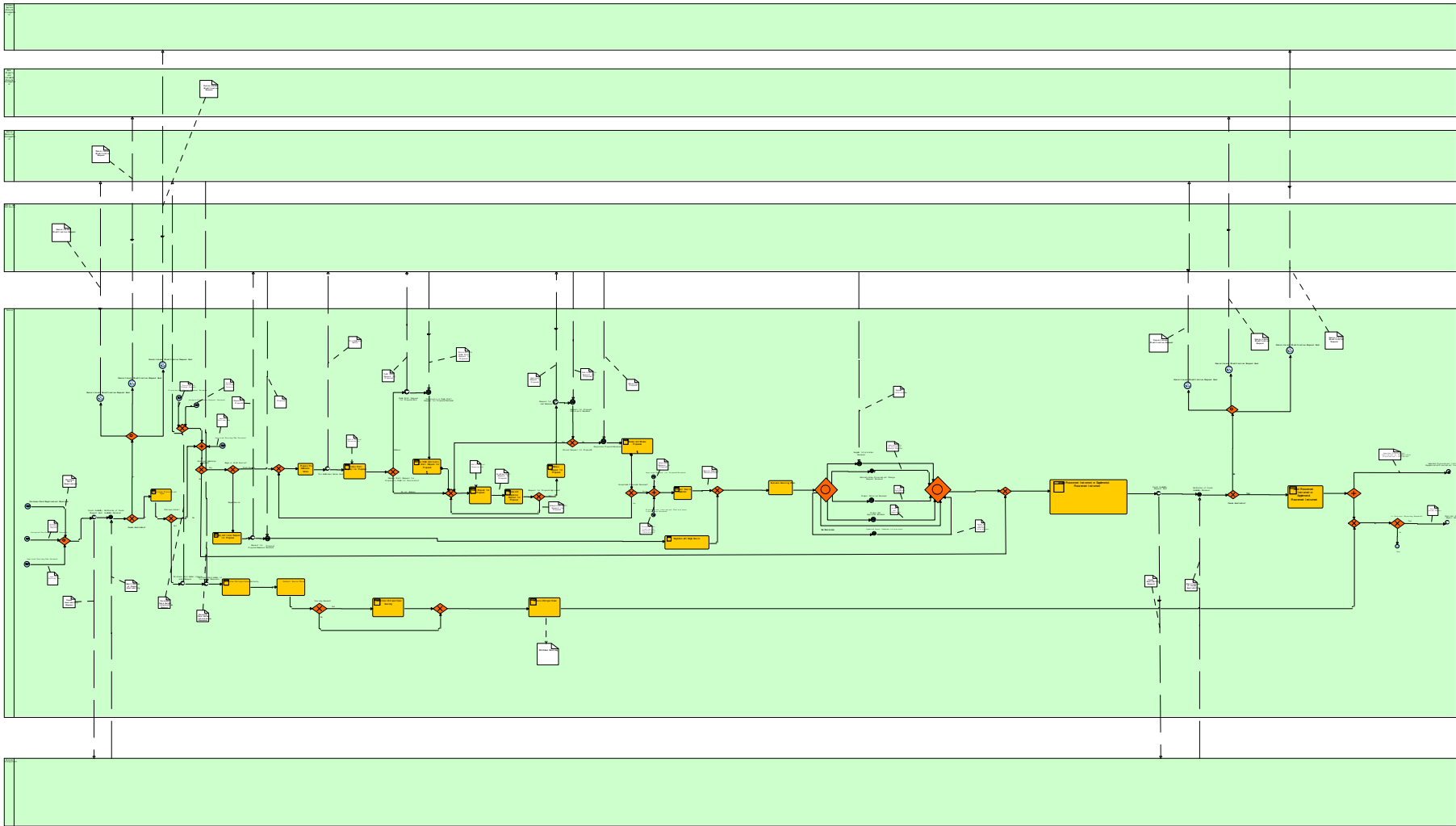

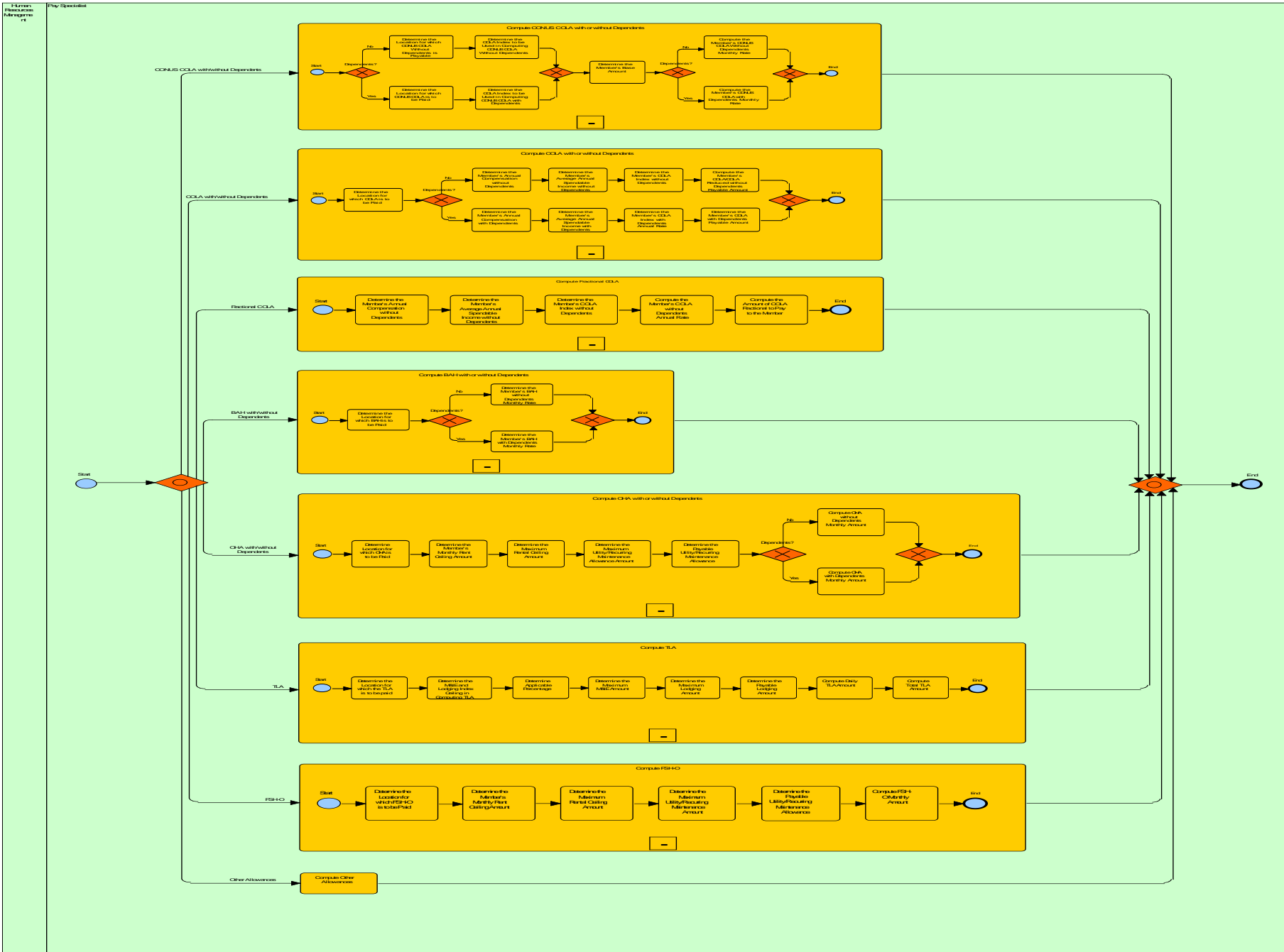

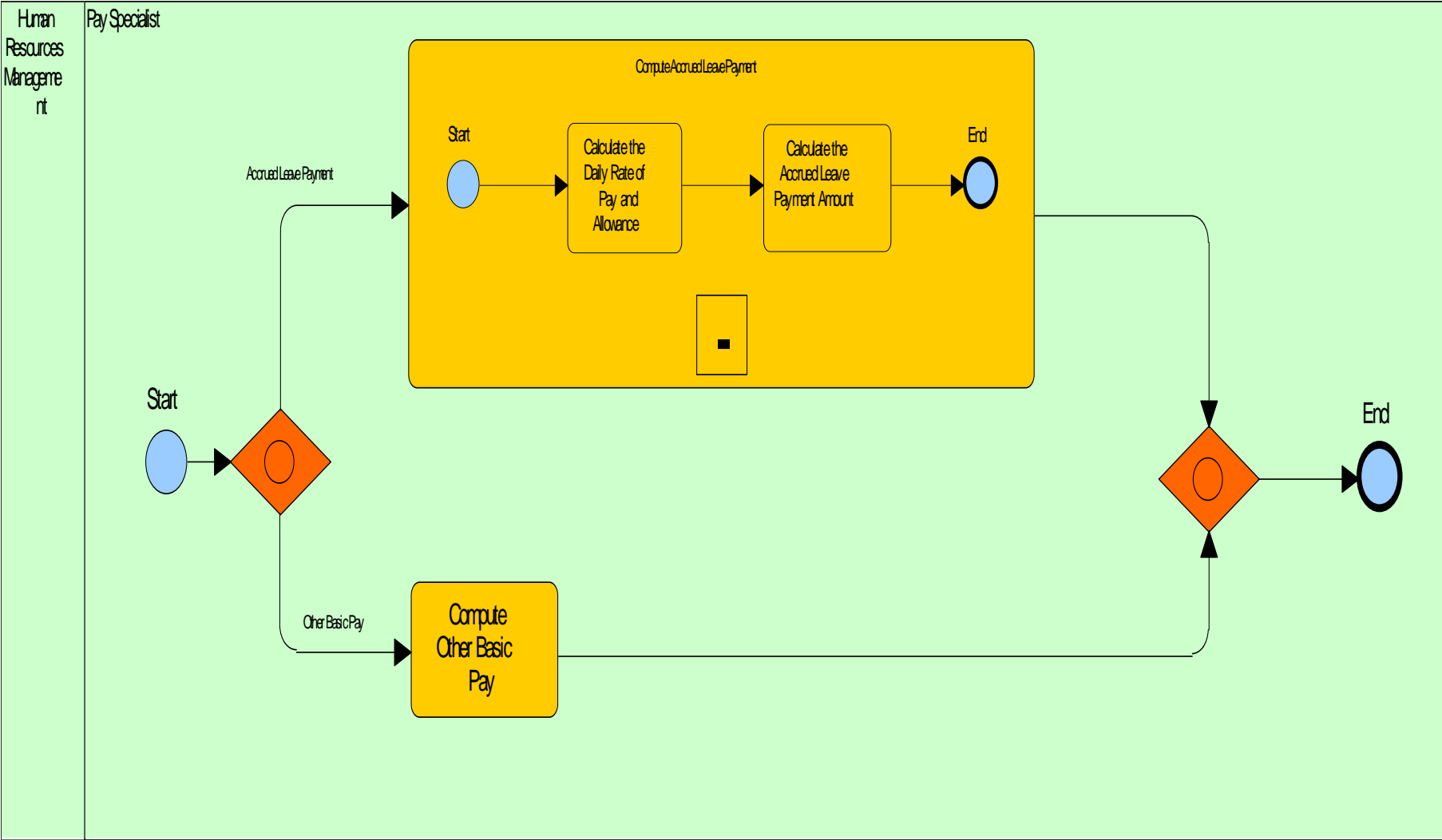

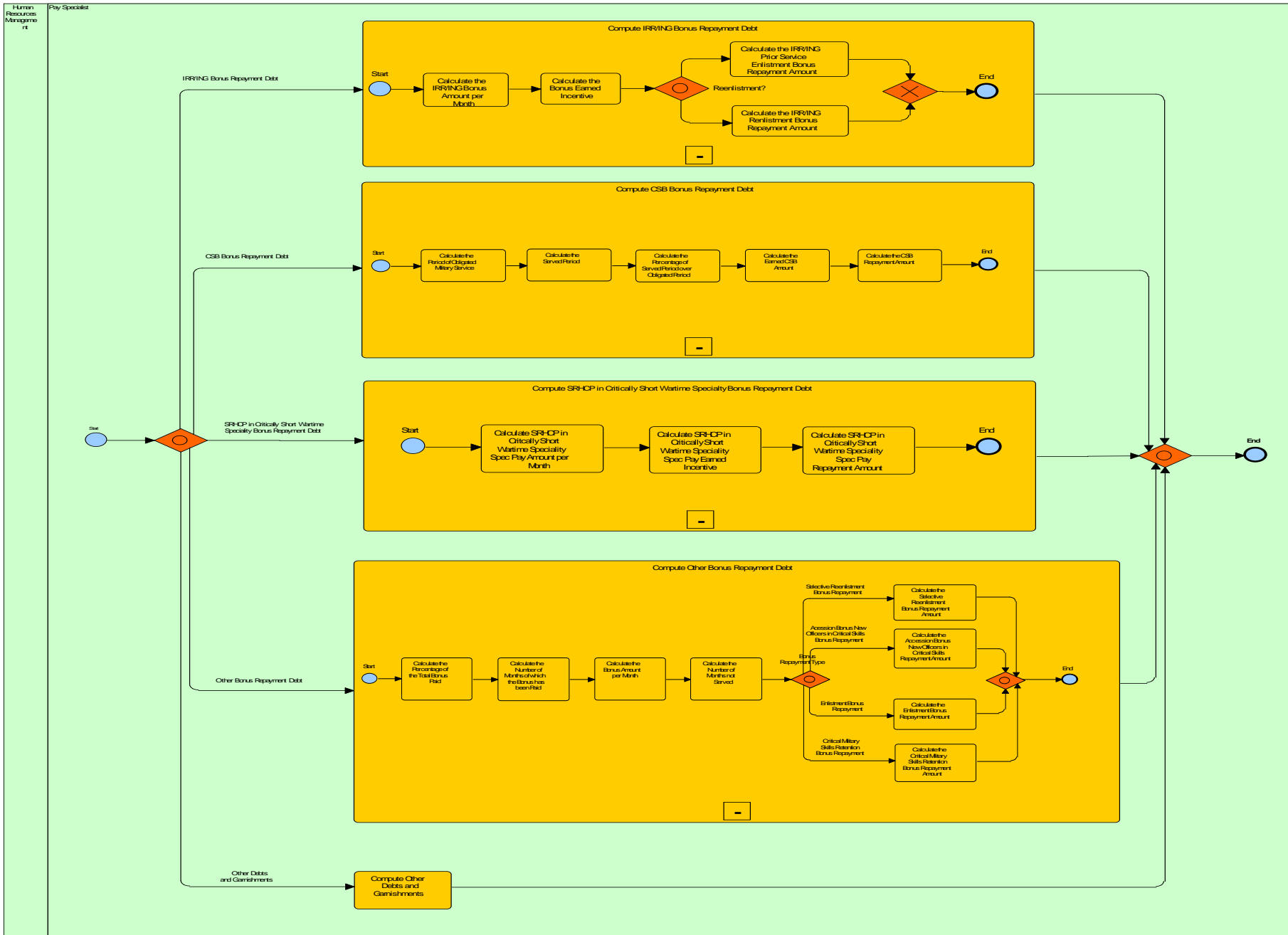

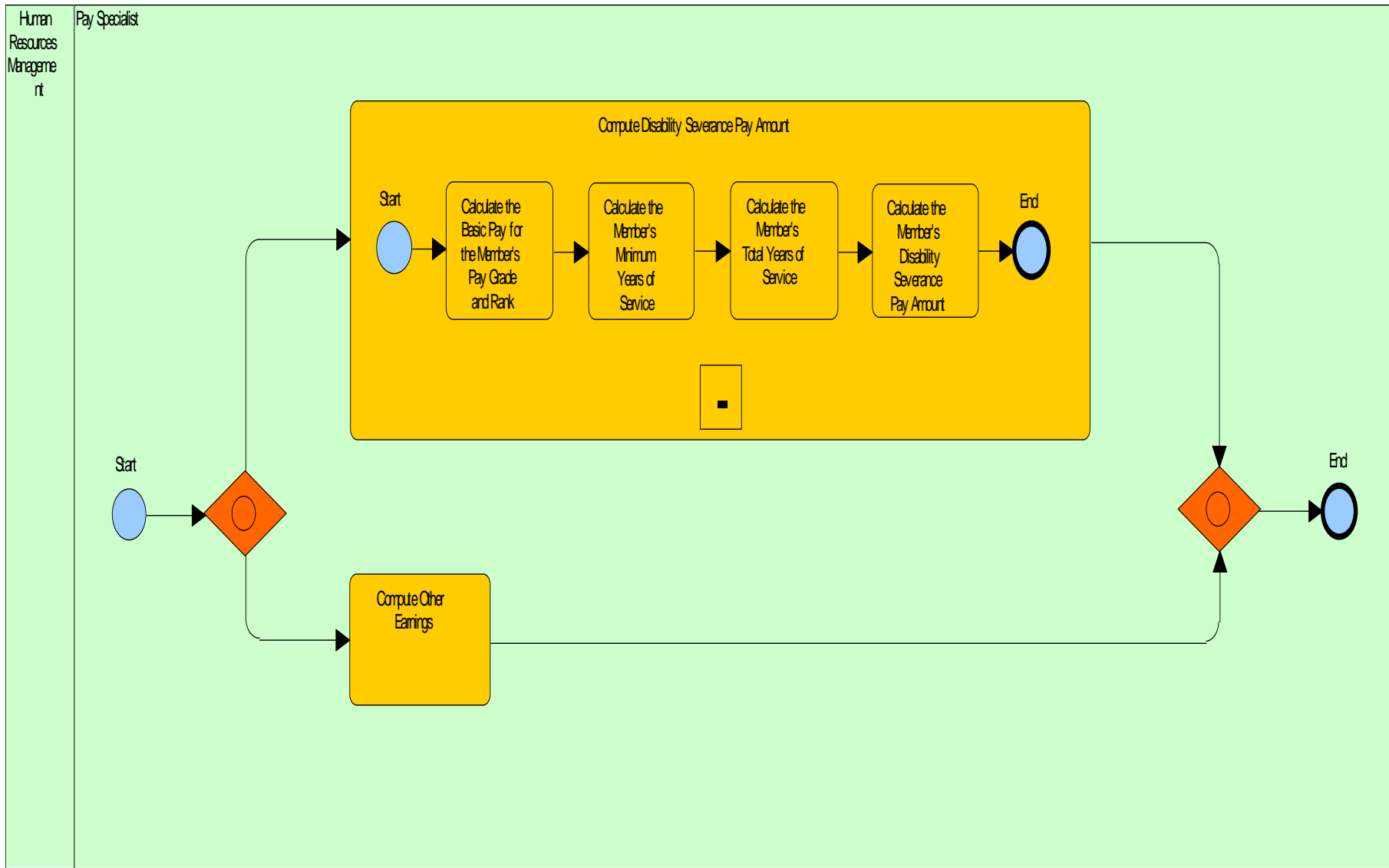

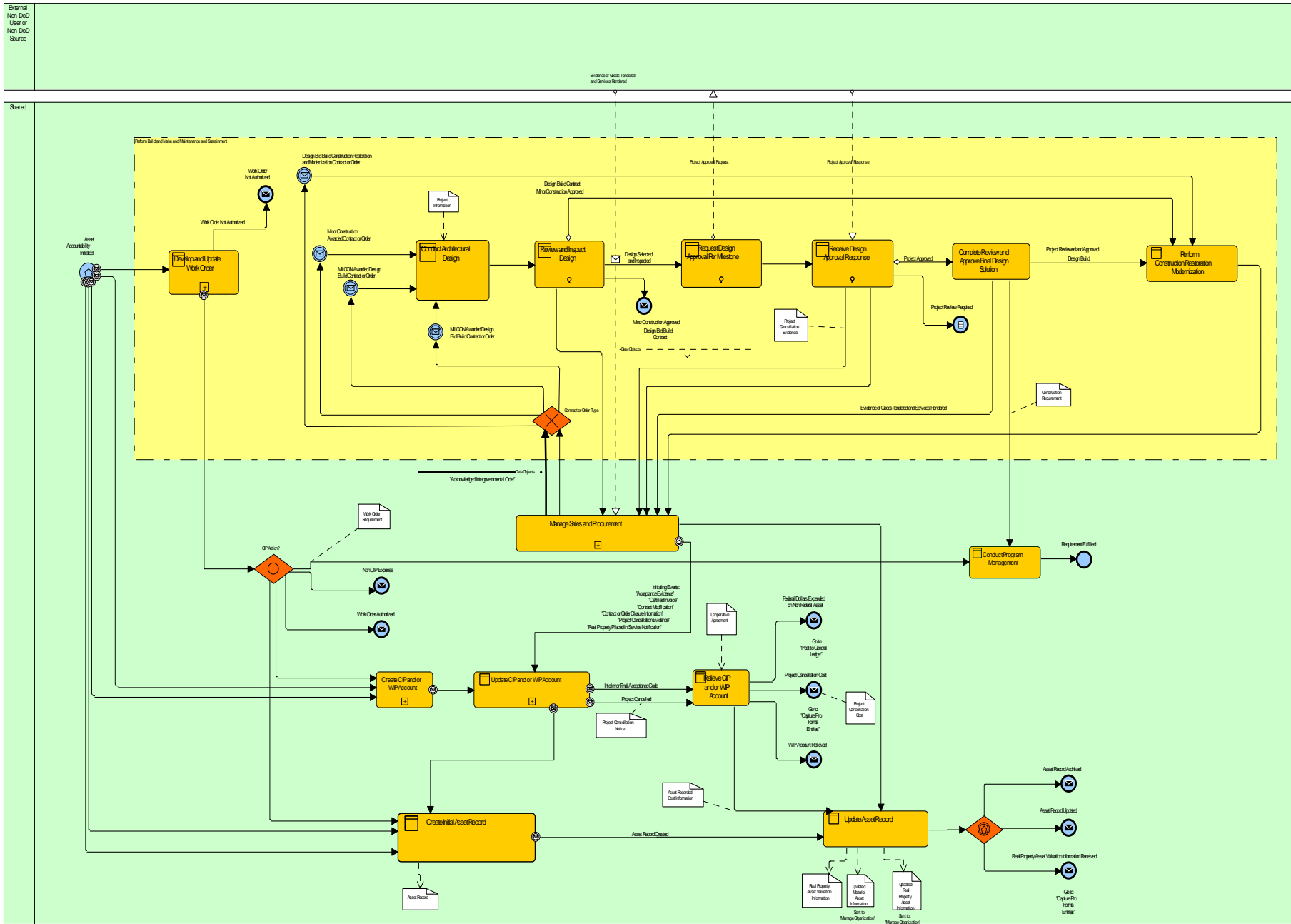

Start

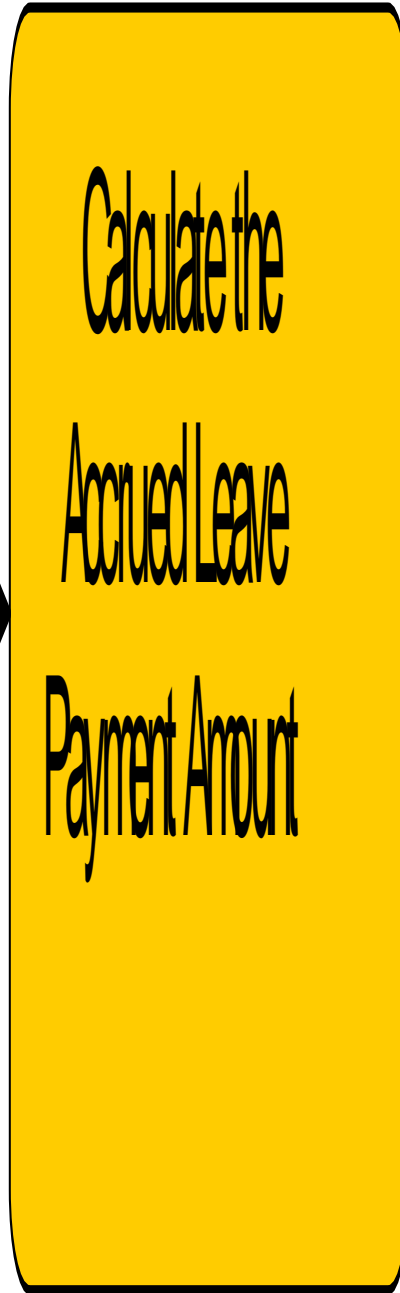
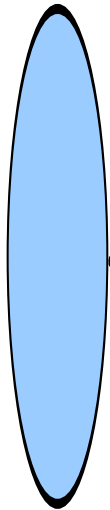

End

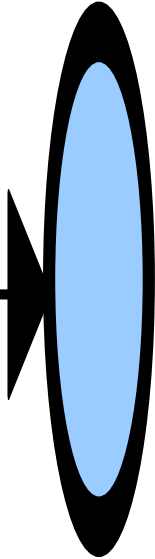

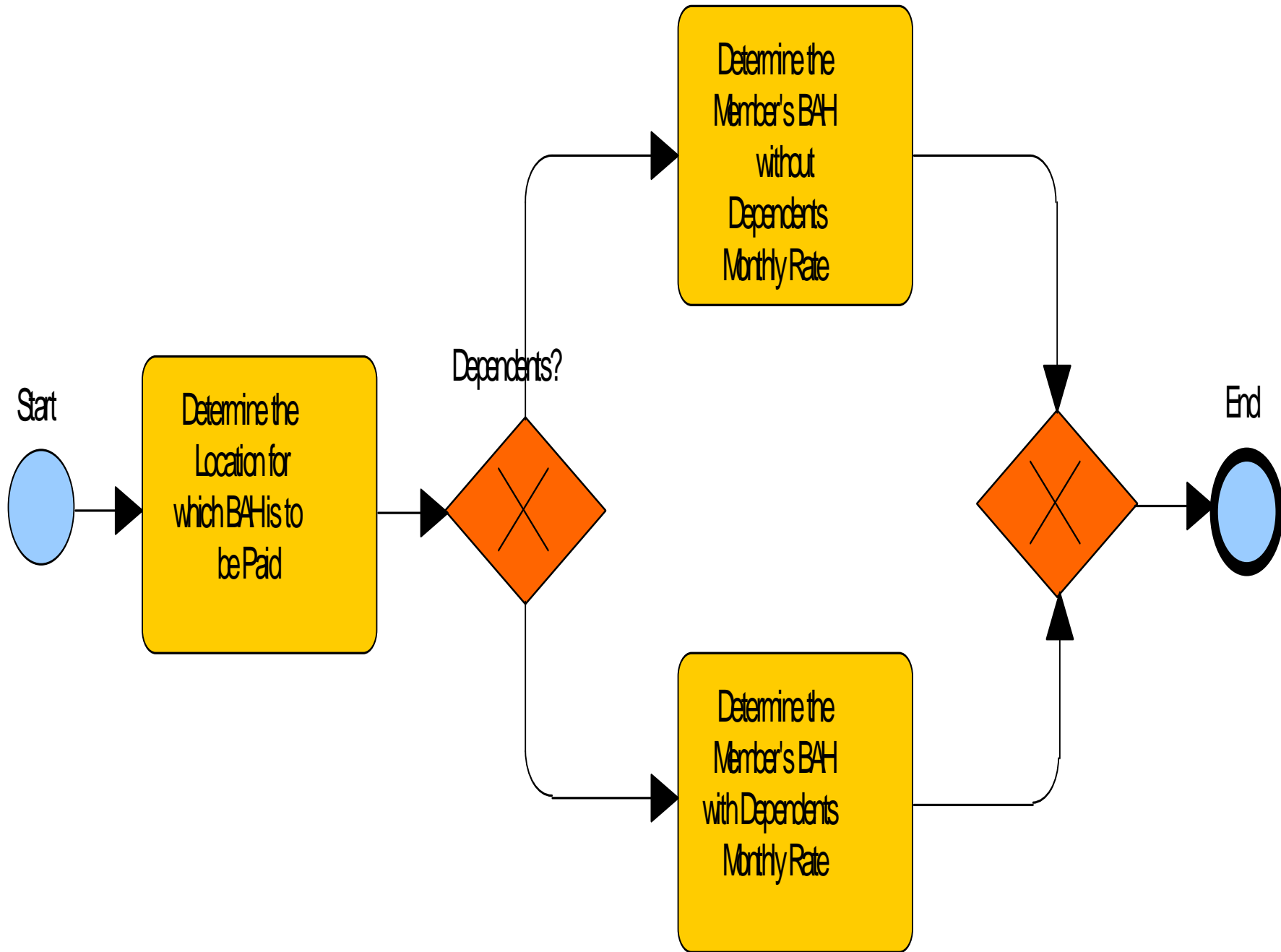

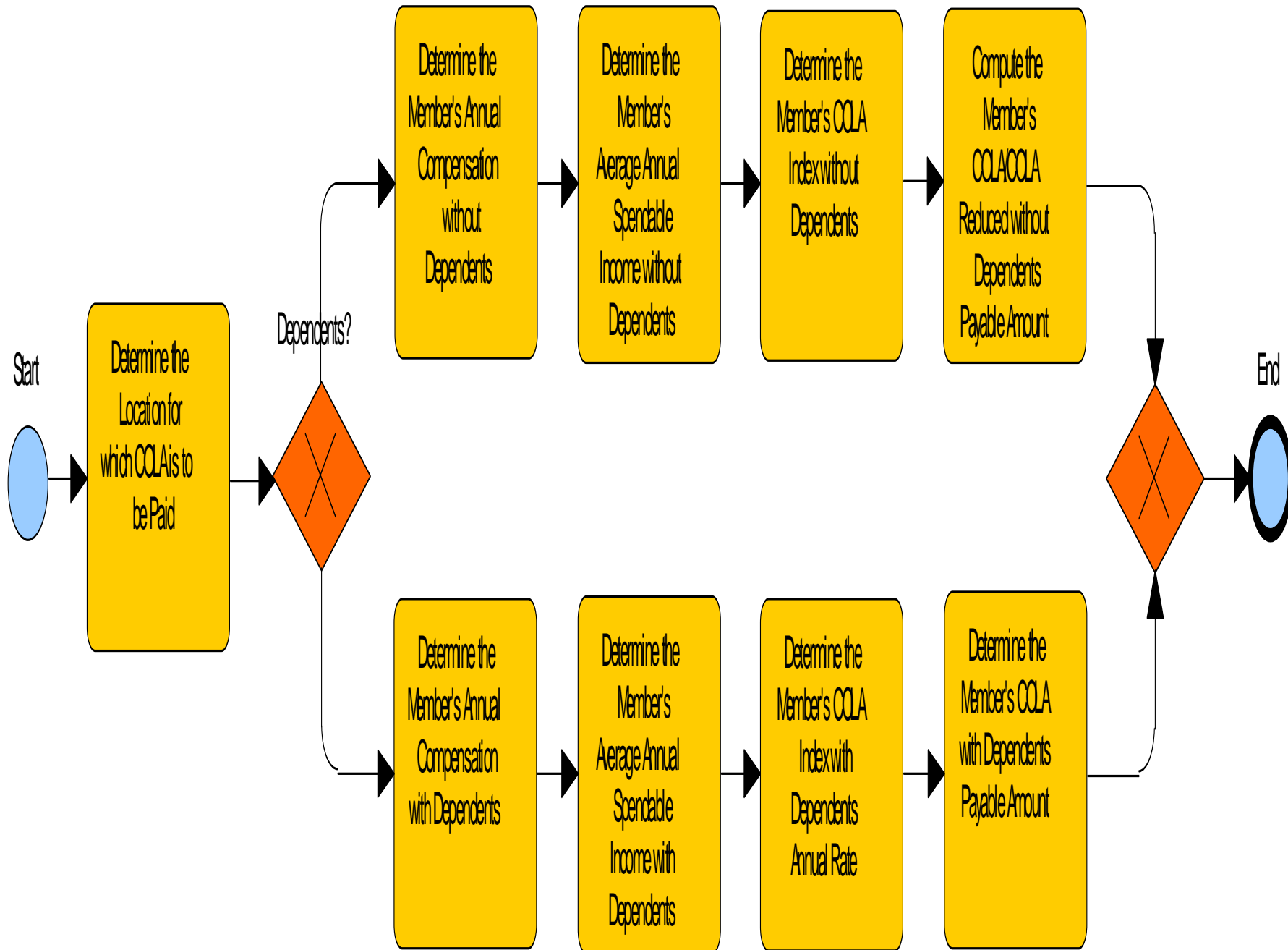

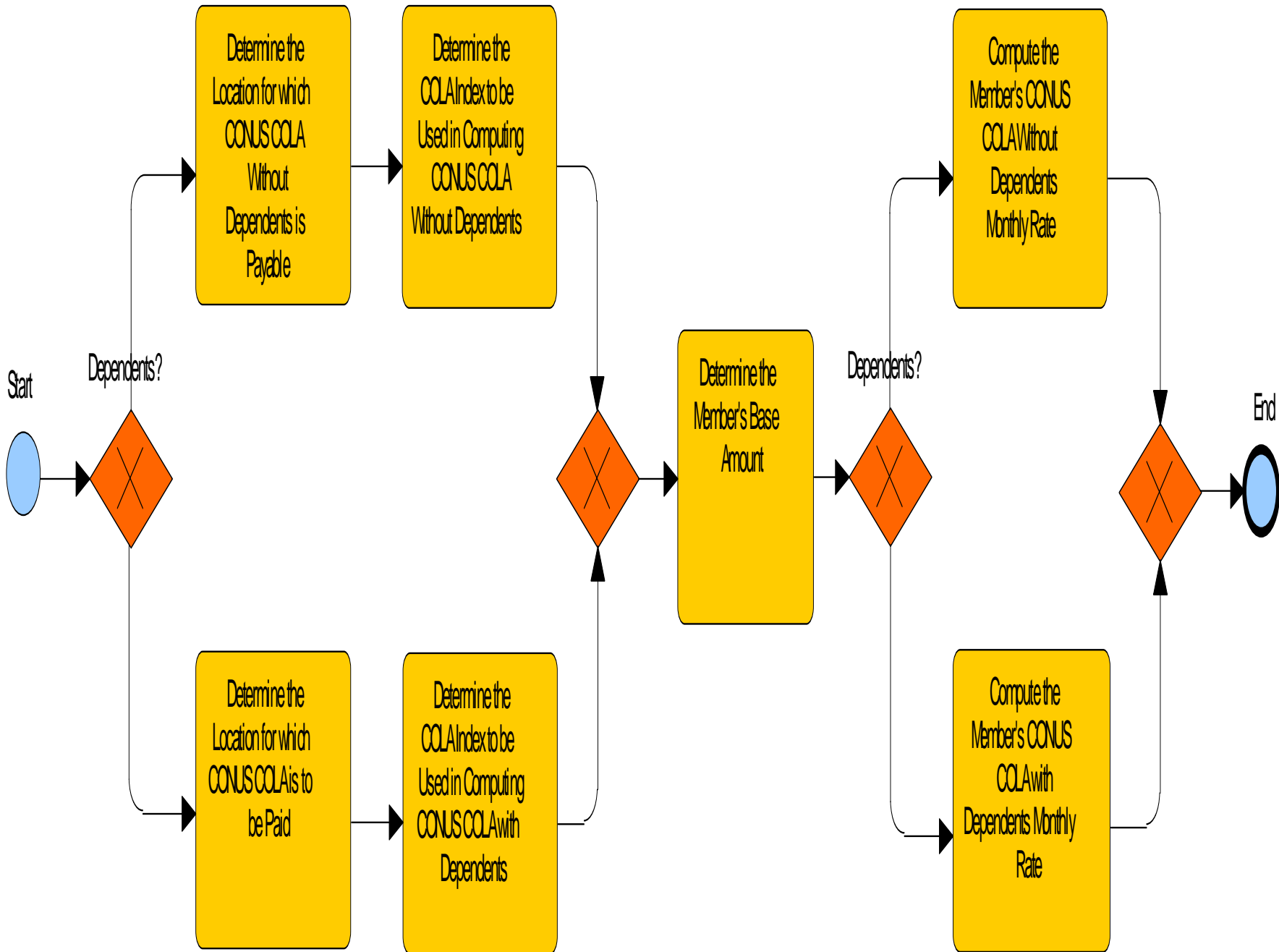

Start



Calculate
Period of Obligated
Military Service

Calculate
Served Period

Calculate
Percentage of
Served Periods
Obligated Period

Calculate
Earned CSB
Amount

Calculate CSB
Requirement Amount

End



Start

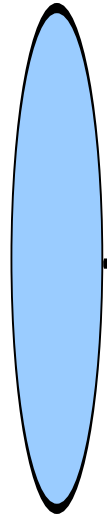

End

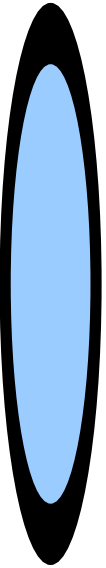

Start

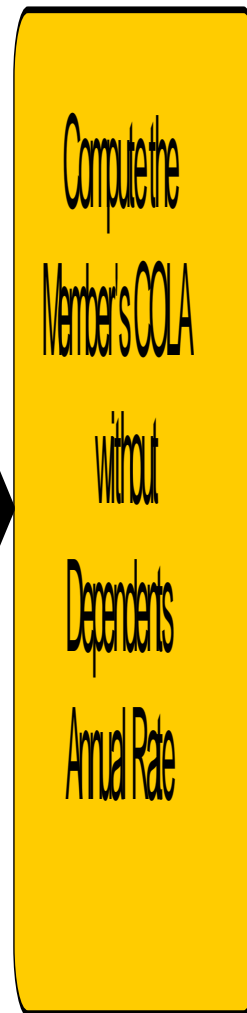
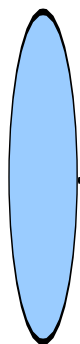

End



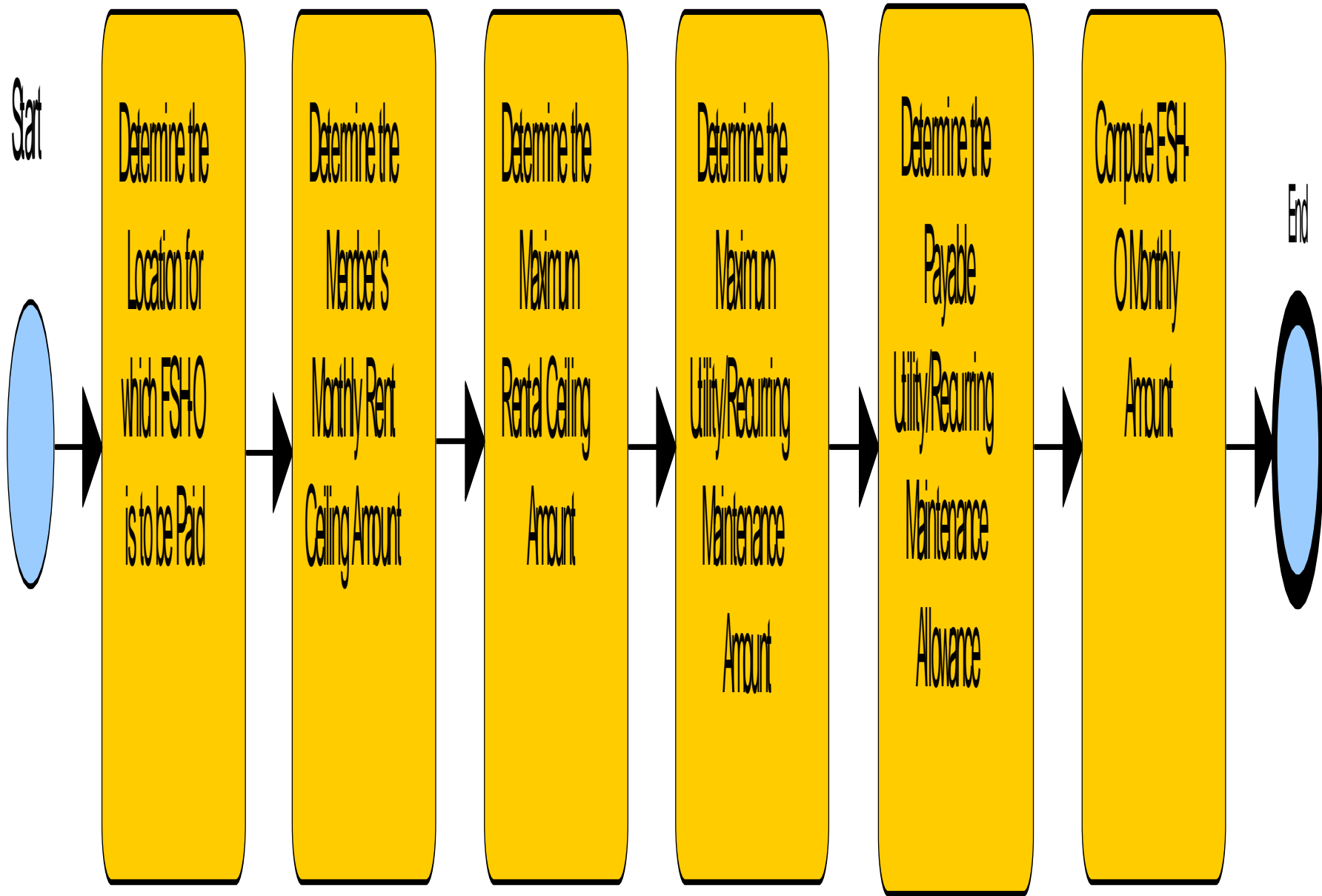

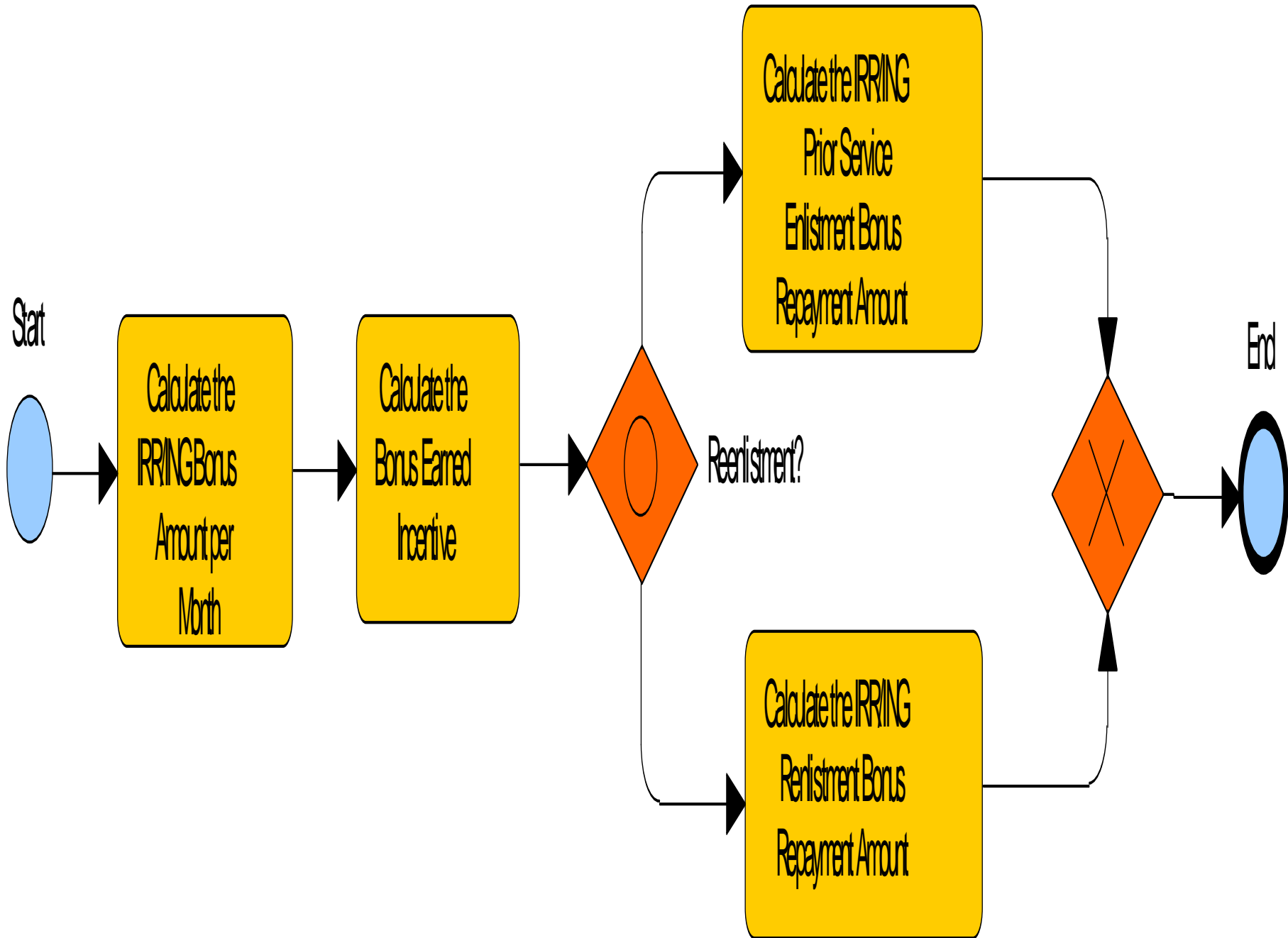

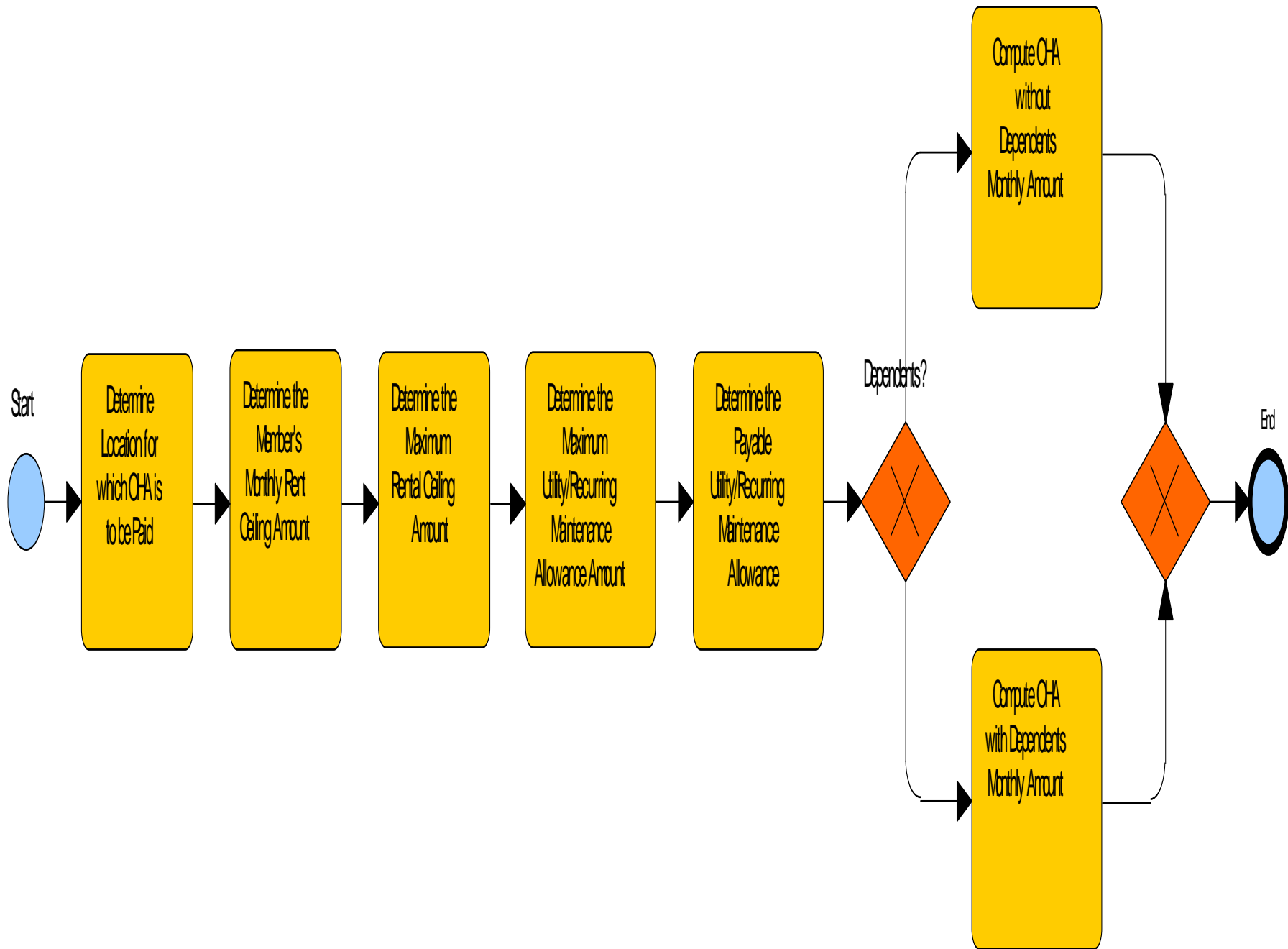

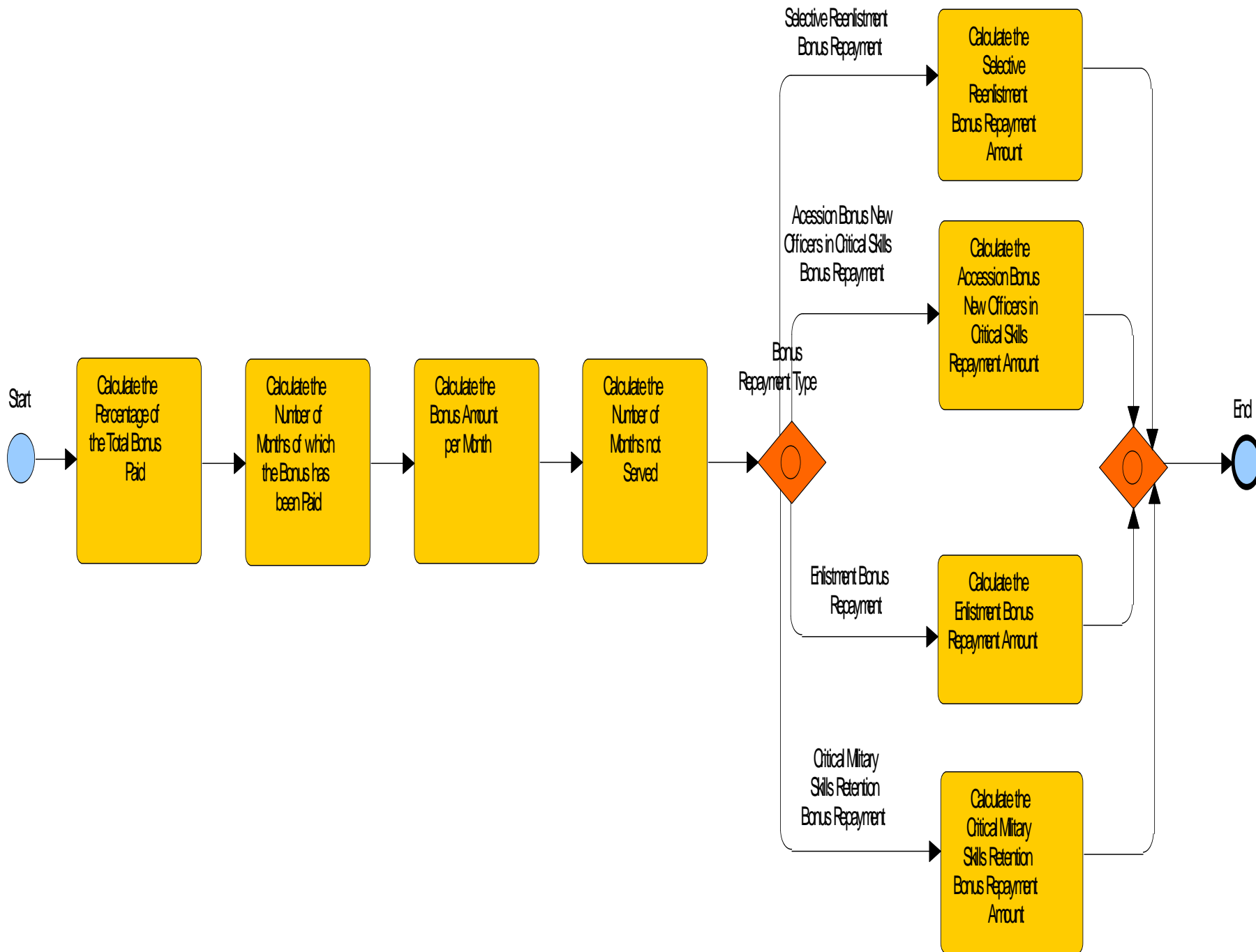

Start

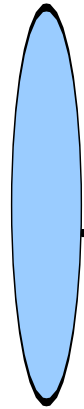

End



Start



Determine
Location for
with the TA
to be Paid

Determine
M/E and
Loading Index
Getting in
Computing TA

Determine
Applicable
Percentage

Determine
Maximum
M/E Amount

Determine
Maximum
Loading
Amount

Determine
Payable
Loading
Amount

Compute Daily
TA Amount

Compute
Total TA
Amount

End



Start

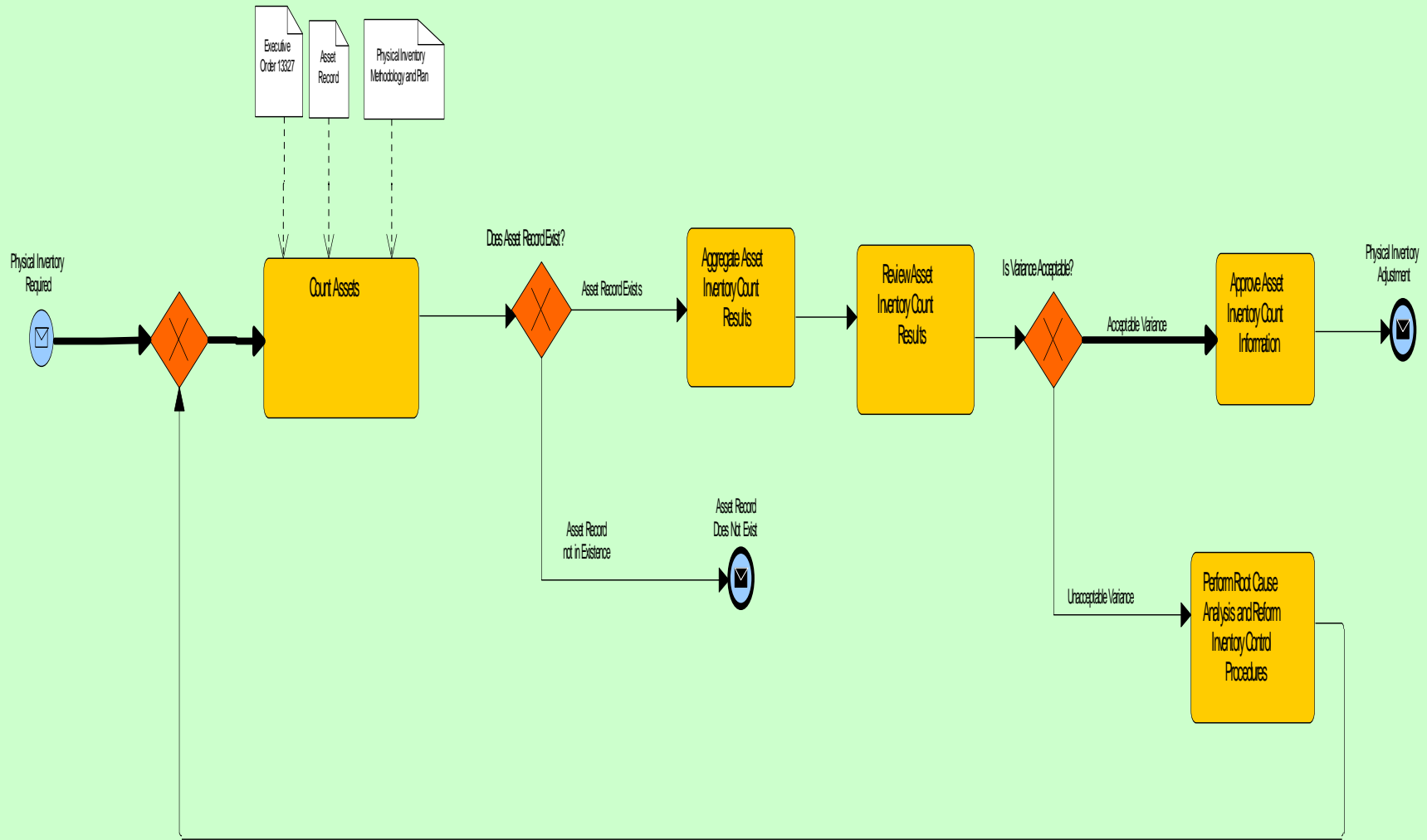

5 Create CP and/or WP Account (O/6: Business Process)

System Architect

Monday, February 13, 2012 3:51 PM

Start

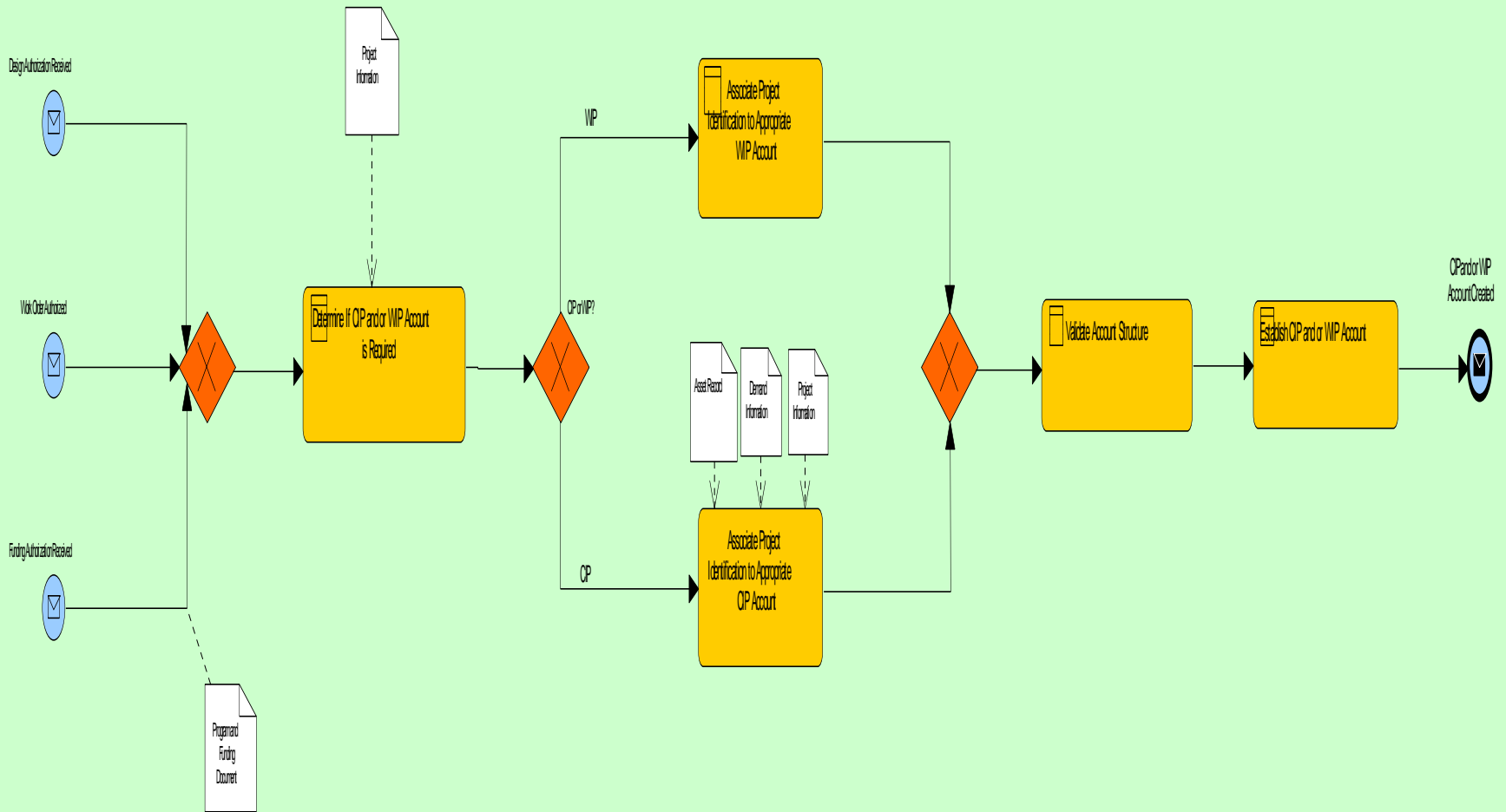

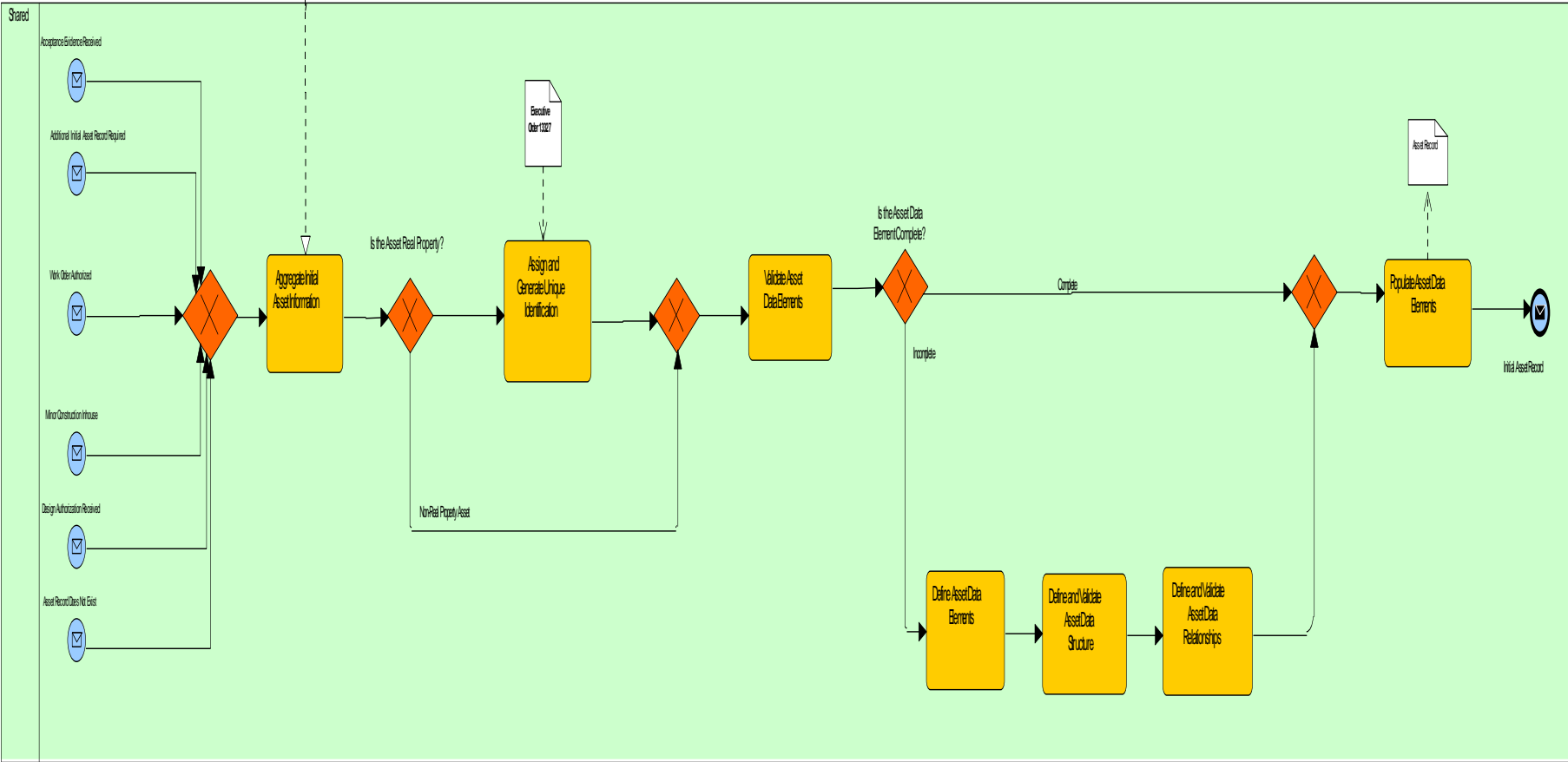
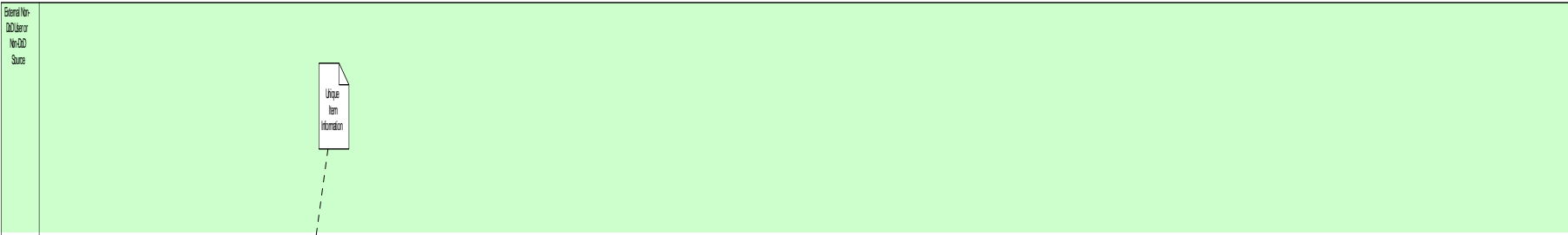

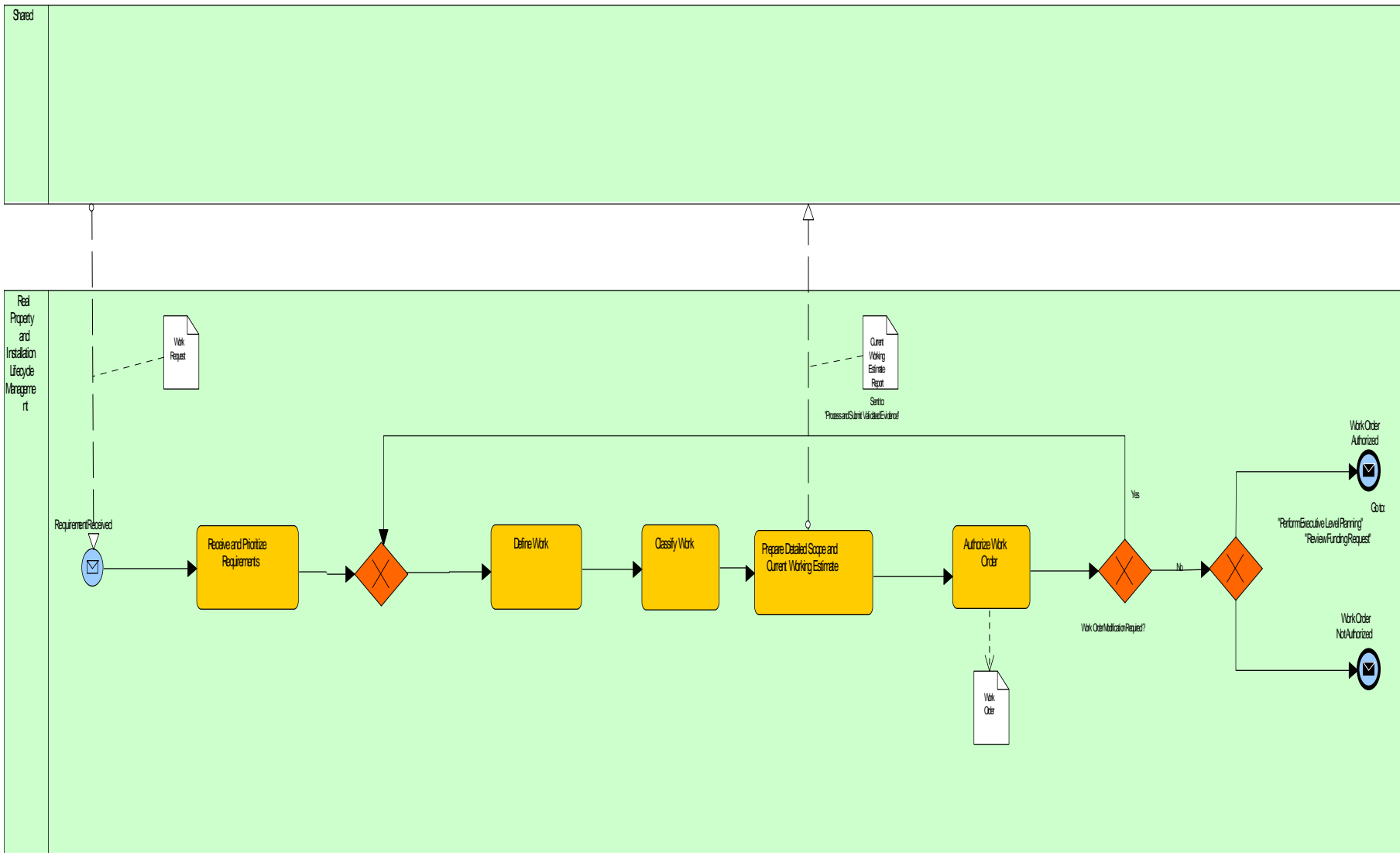

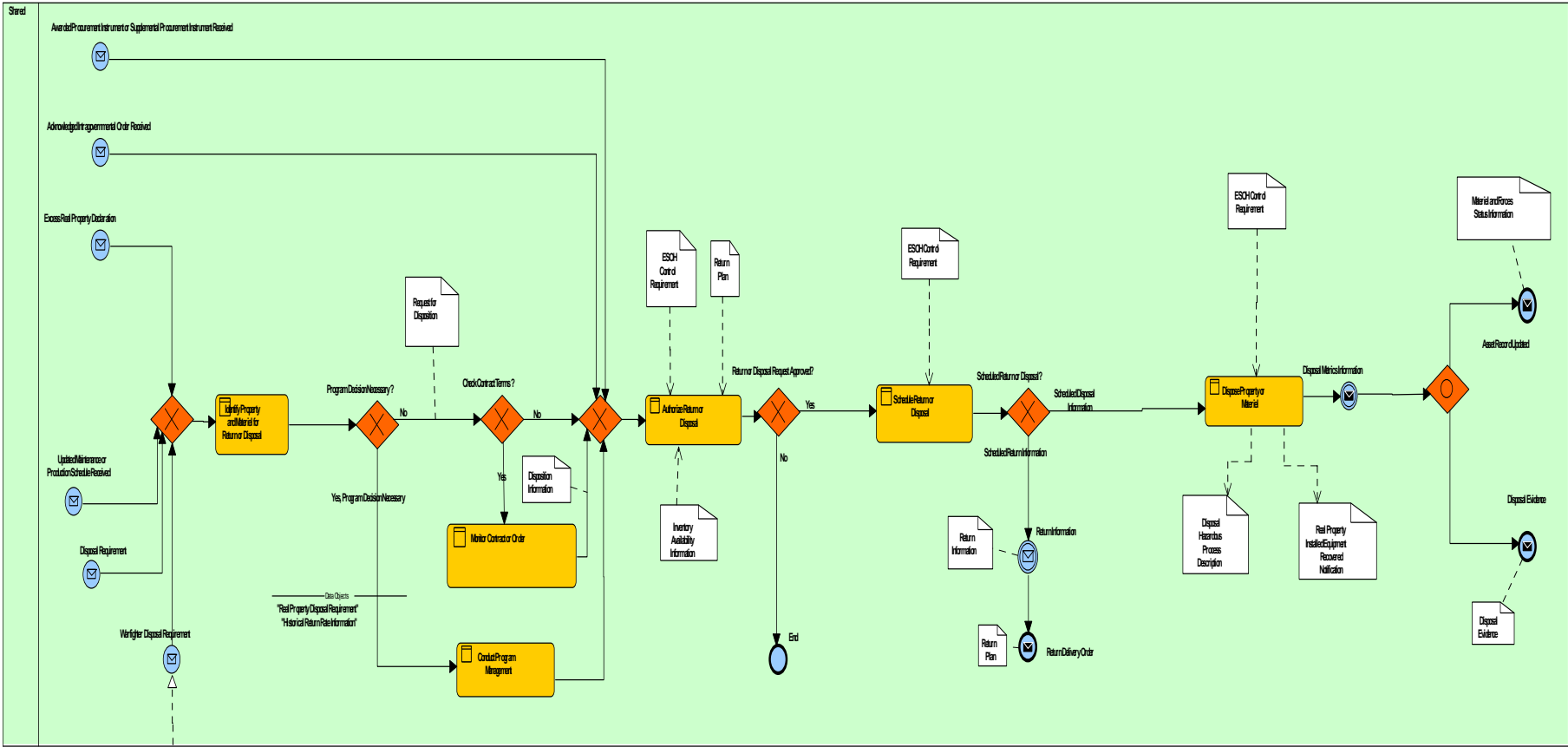

Modifier or DoD User or DoD Same

DoD Technology Export (OV-6c Business Process)
 System Architect
 Monday, February 13, 2012

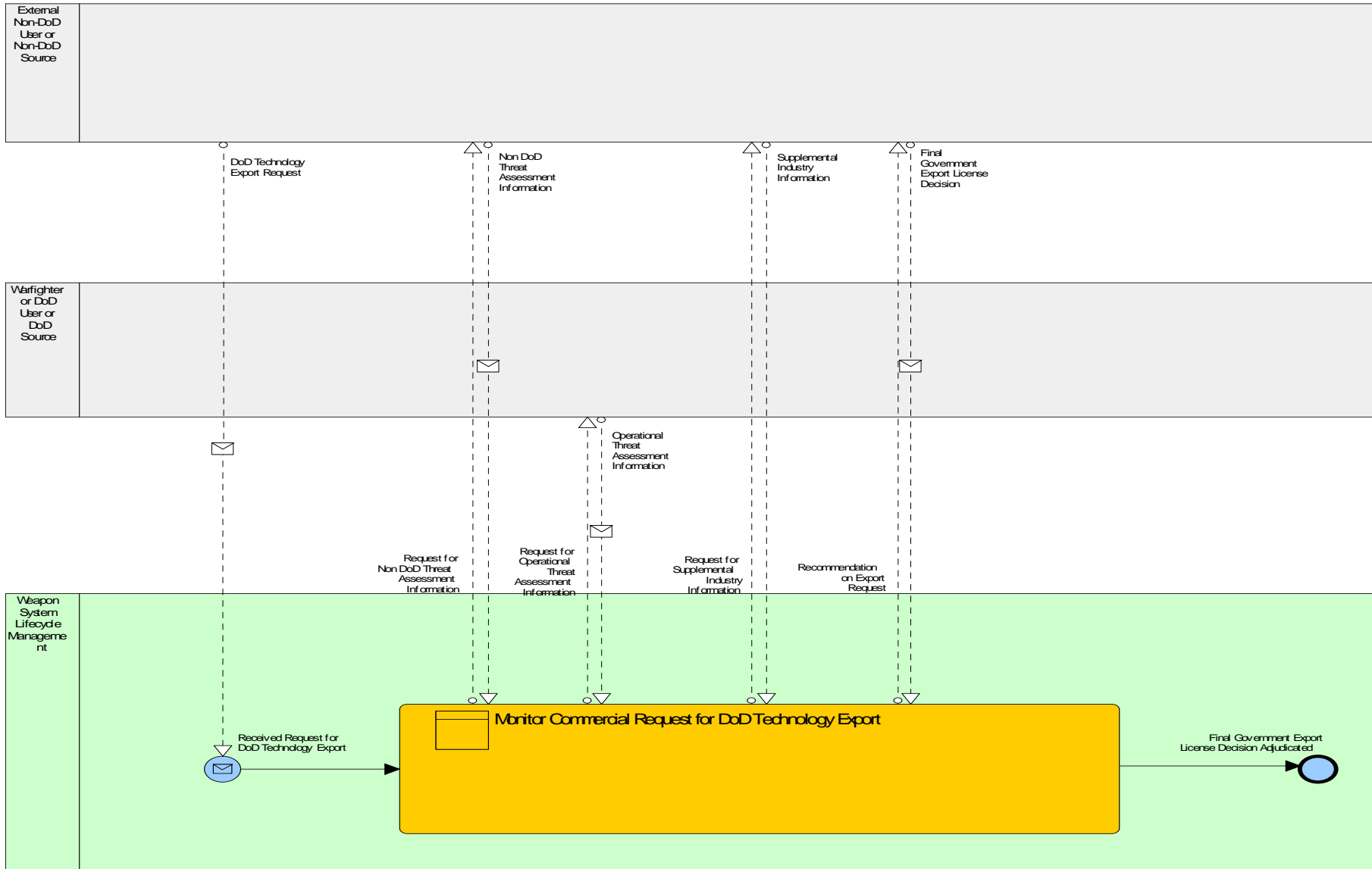

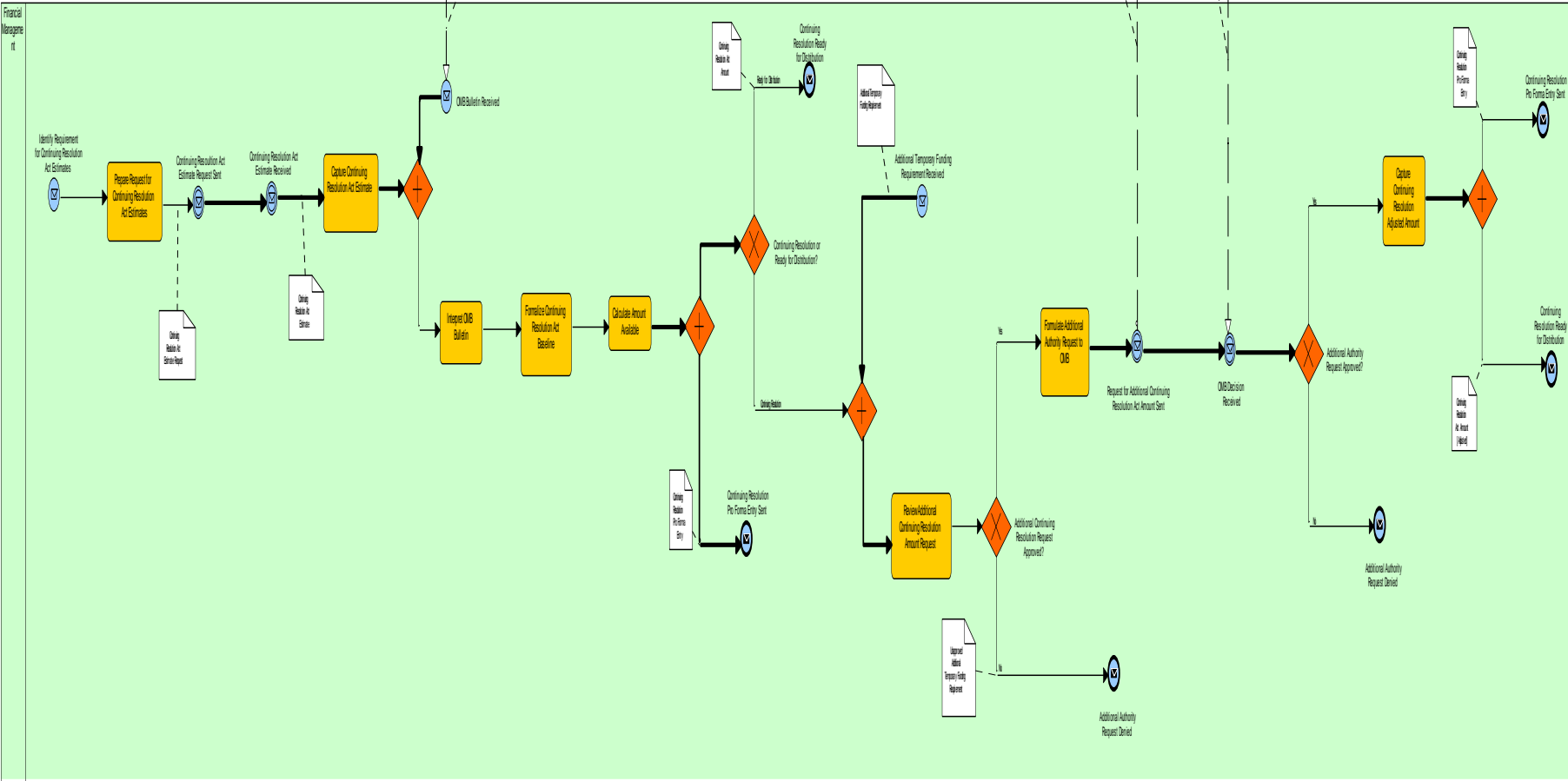
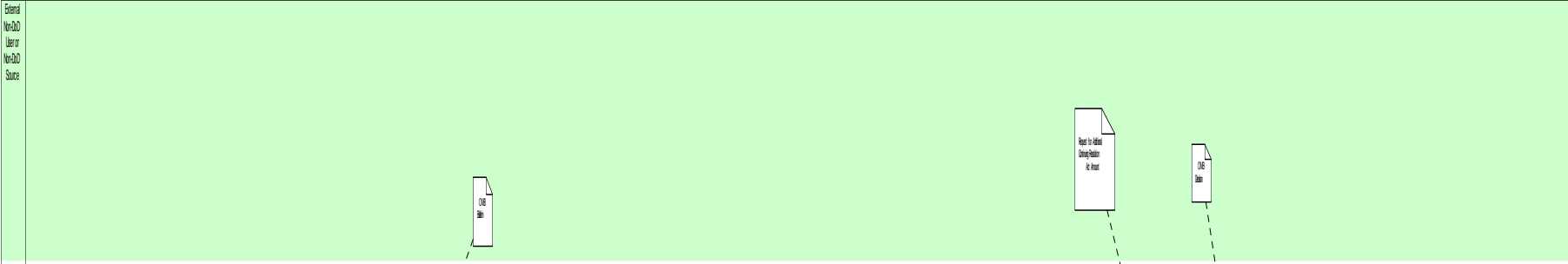

Execute Program (OV-6c Business Process)
 System Architect
 Monday, February 13, 2012 5:00 PM

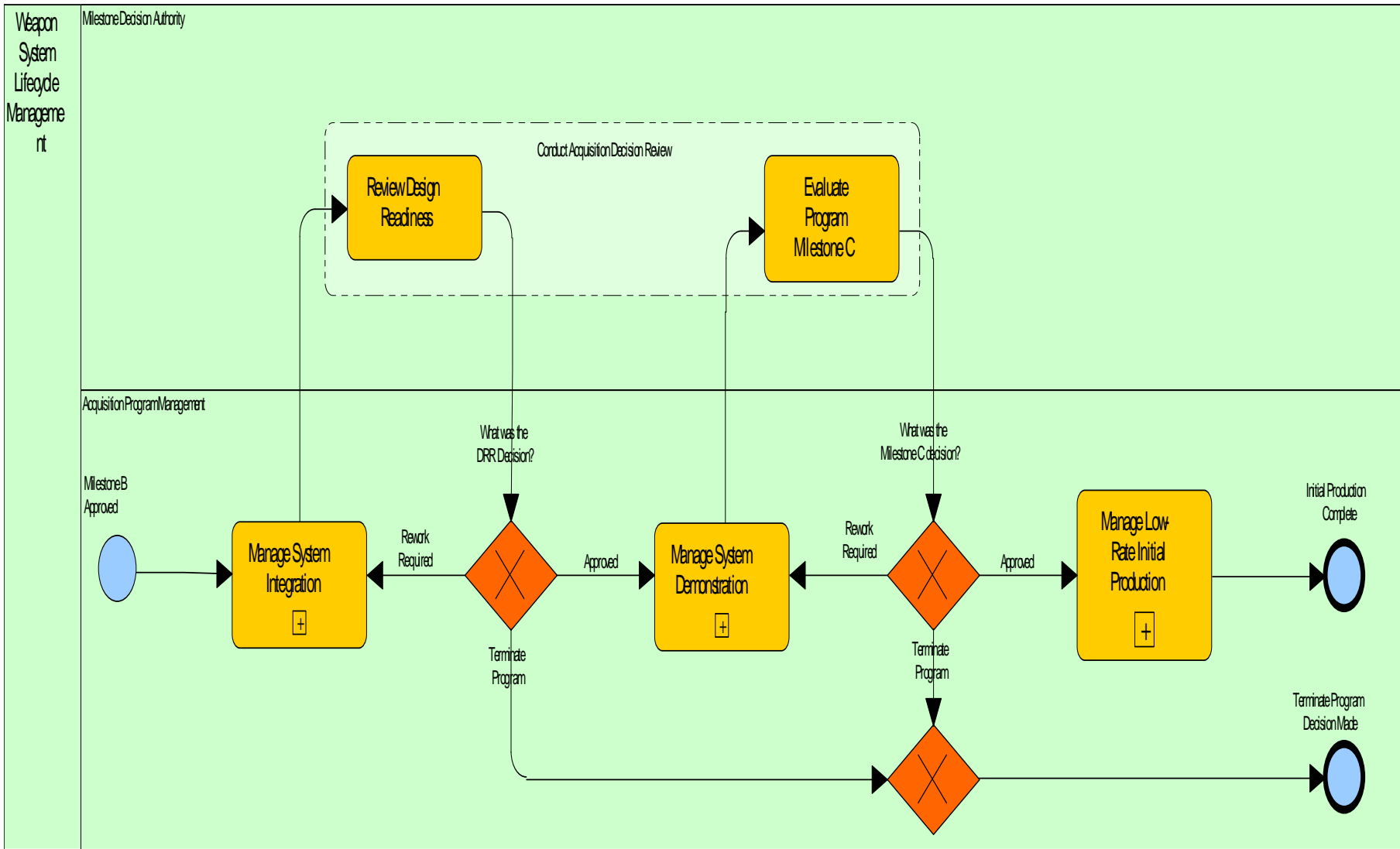

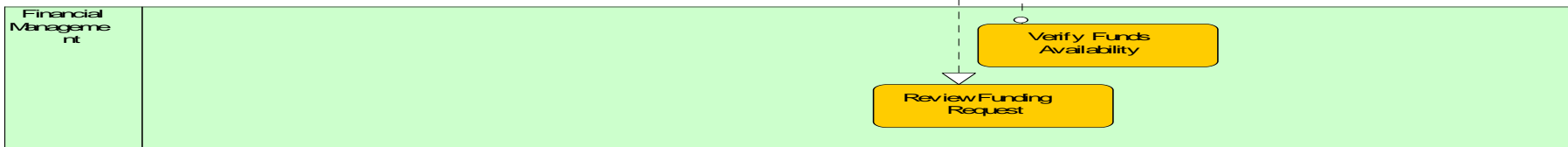
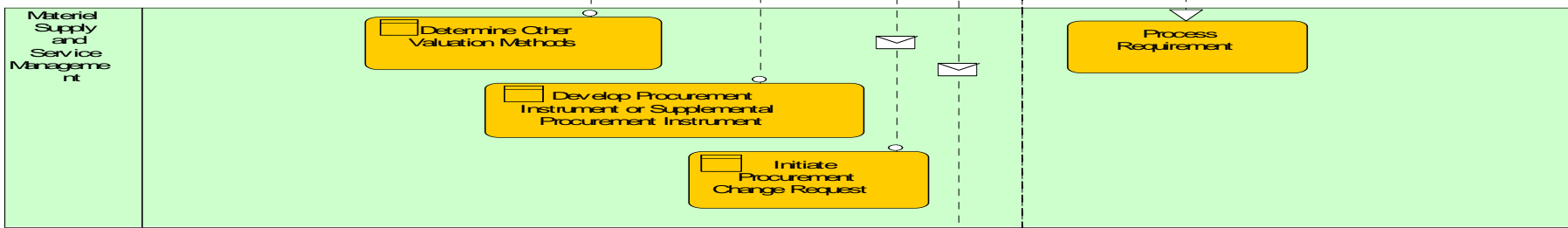
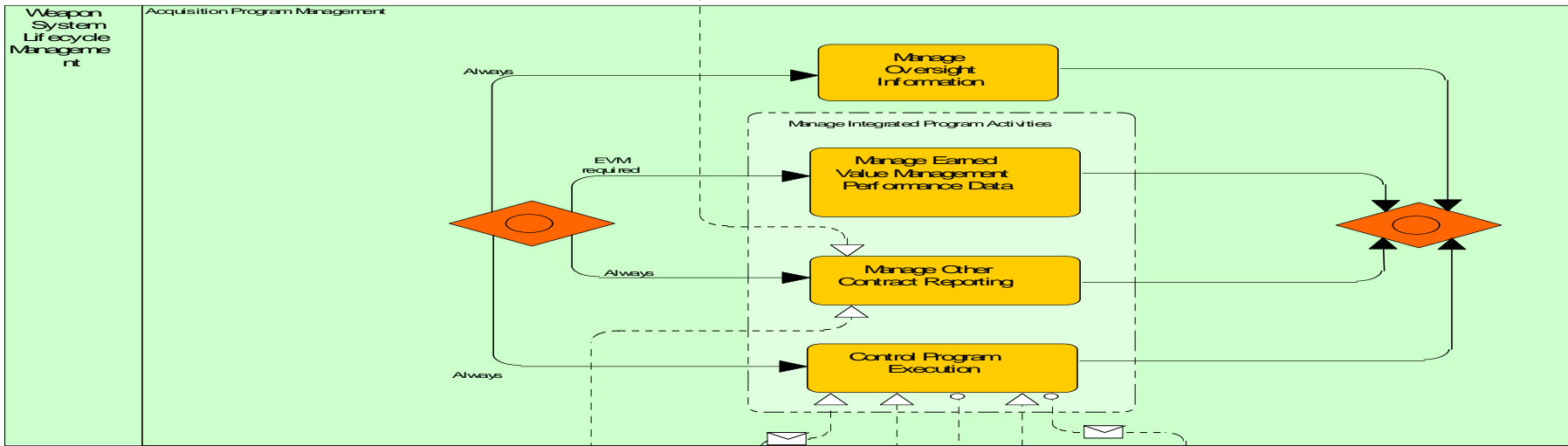
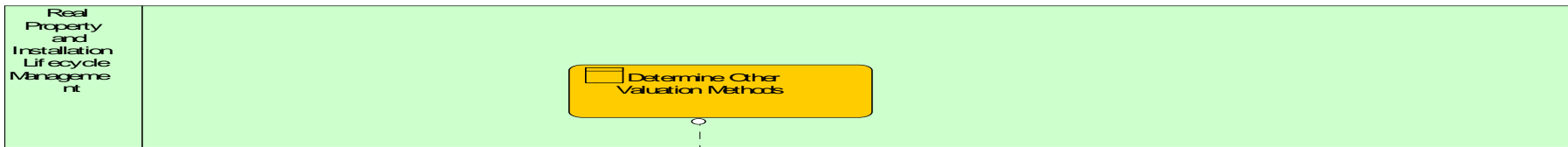

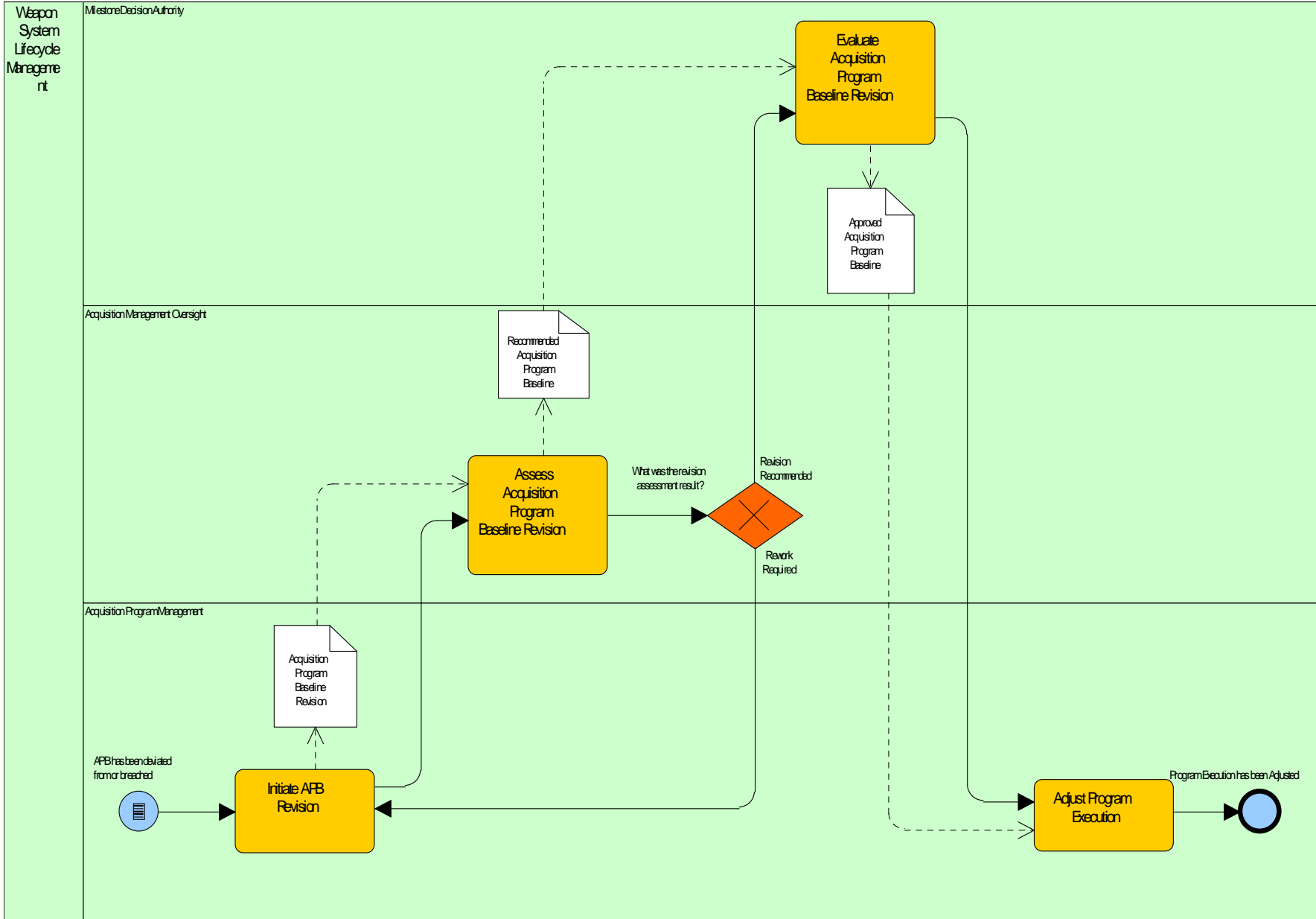

Execute Requisition (OV-6c Business Process)
 System Architect
 Friday, December 28, 2012 2:24 PM
 Procure to Pay OV-6c Process Model

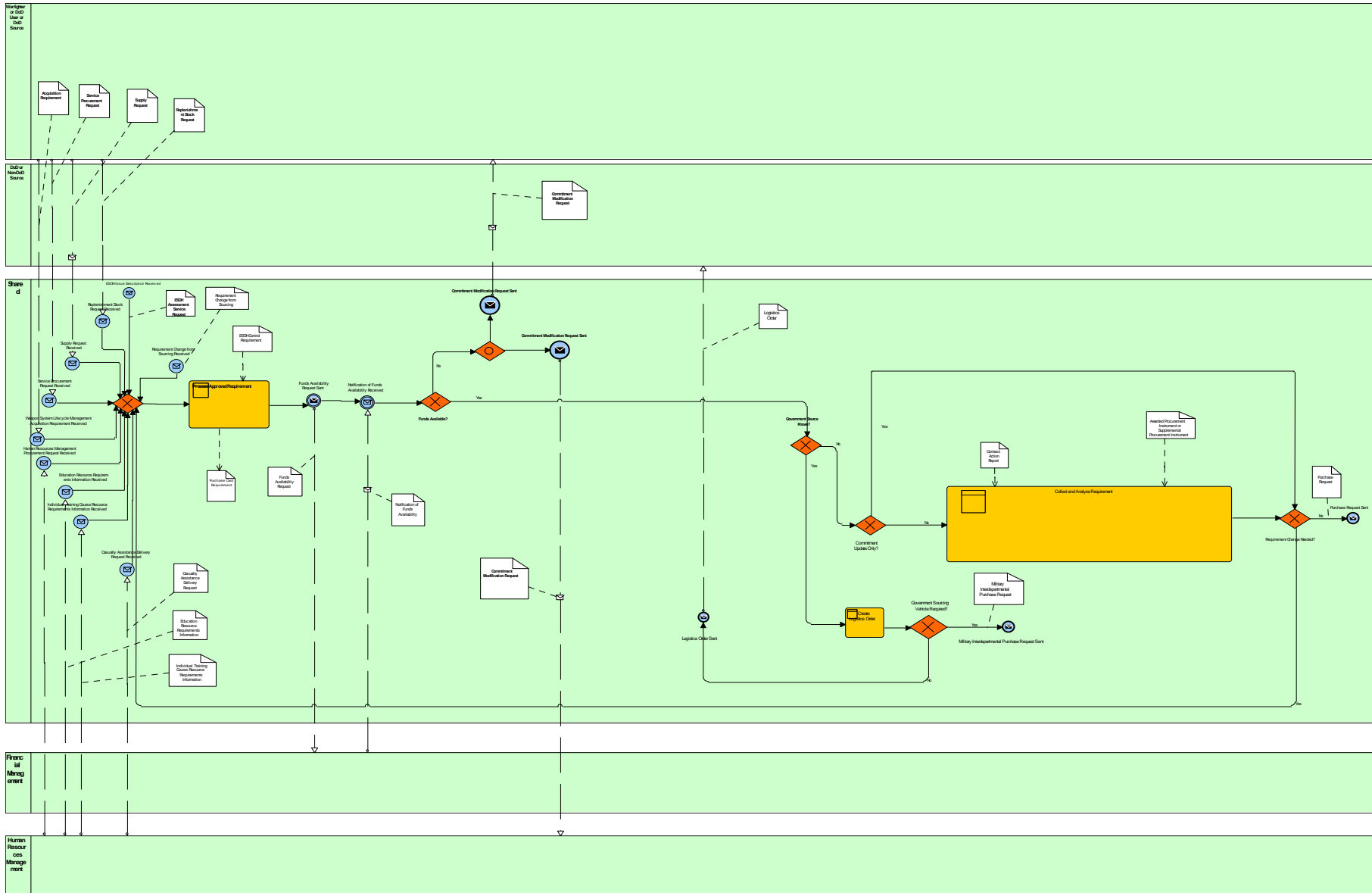

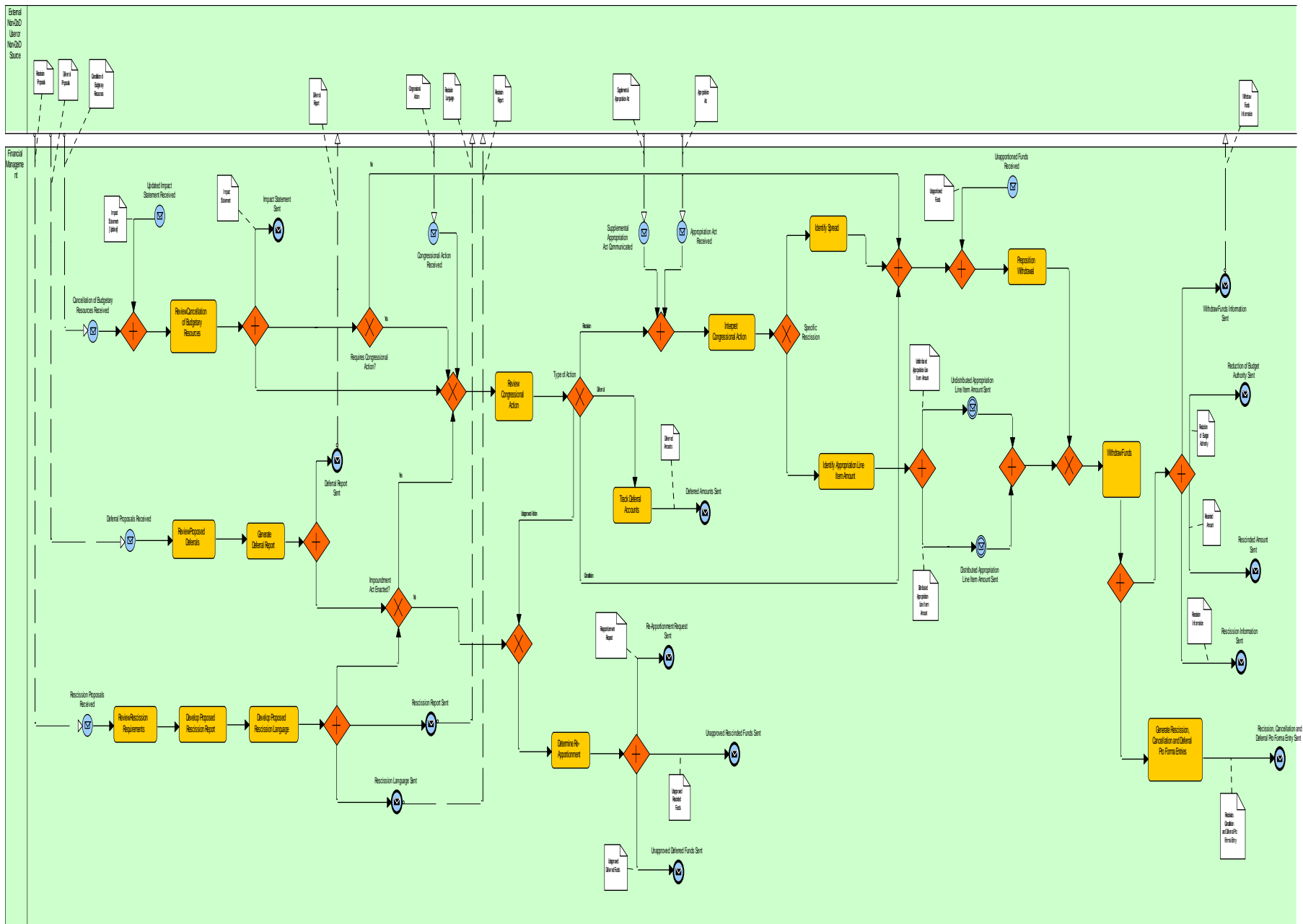

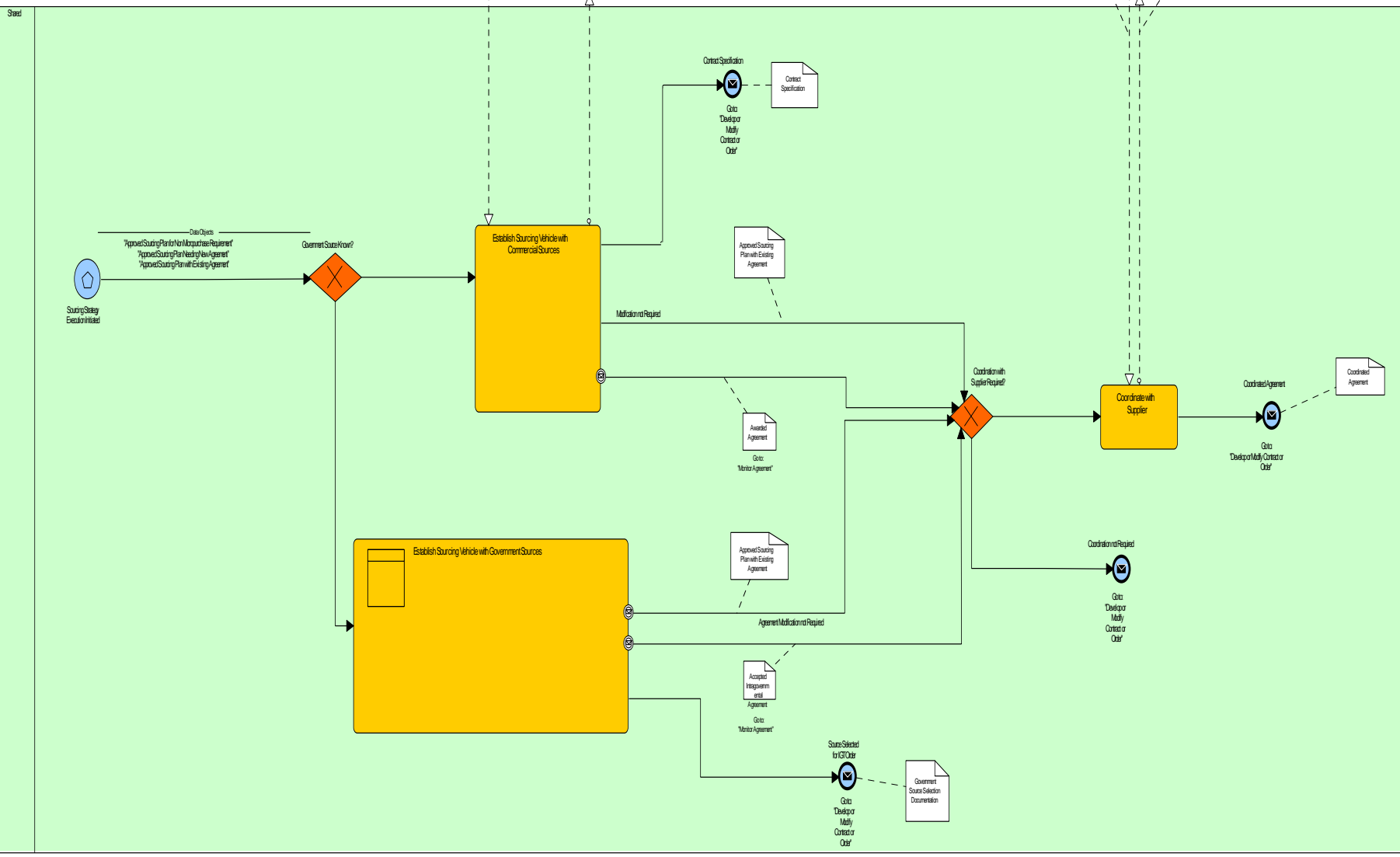
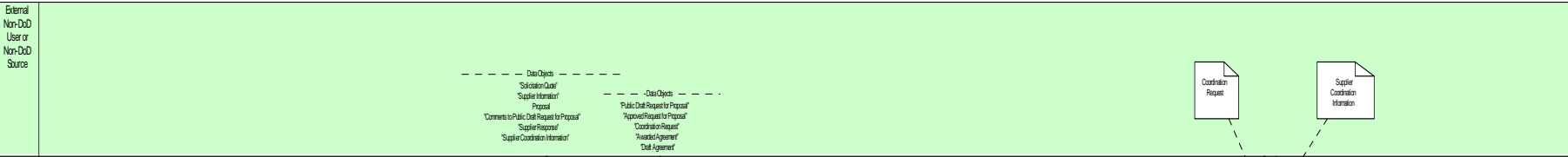

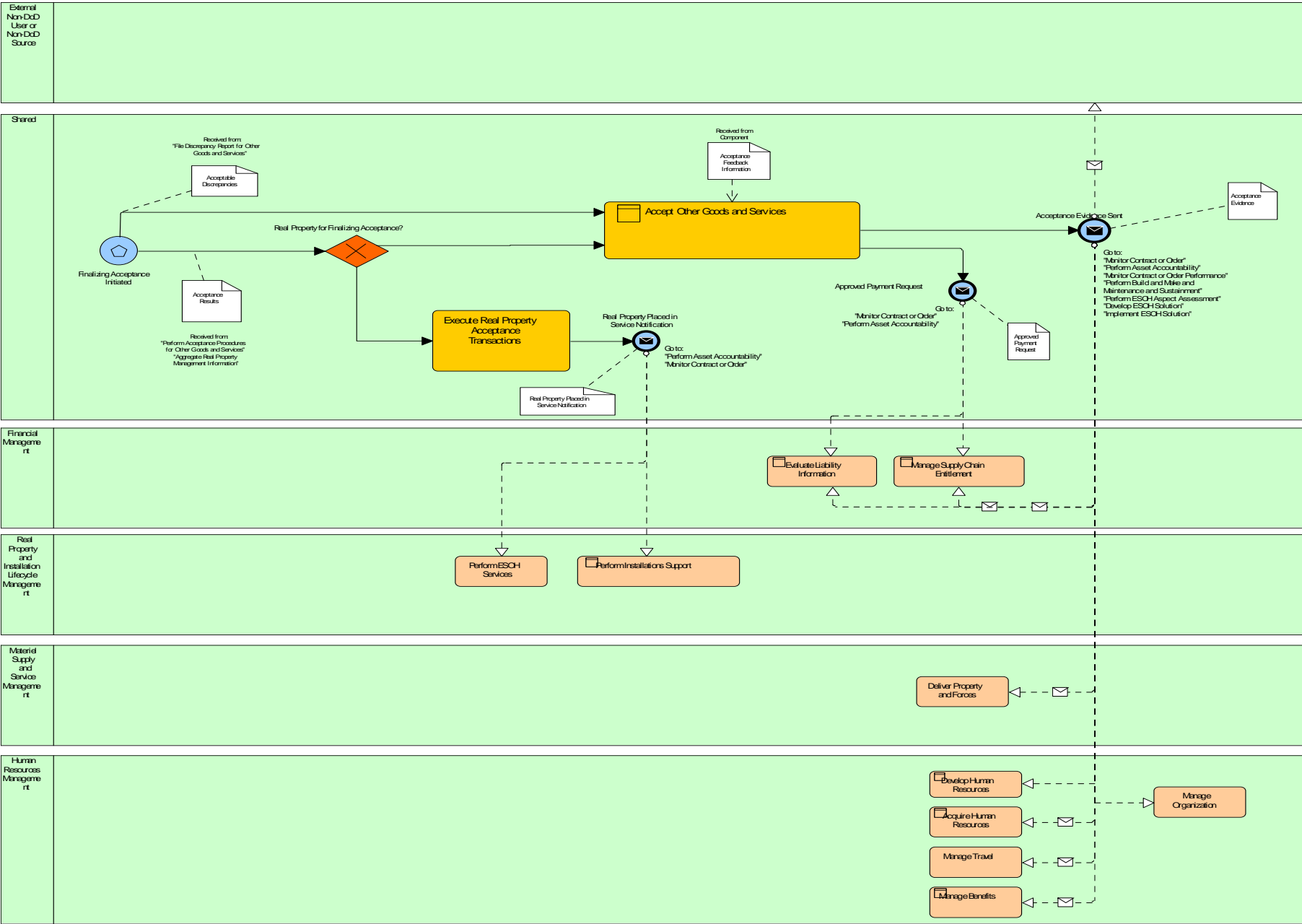

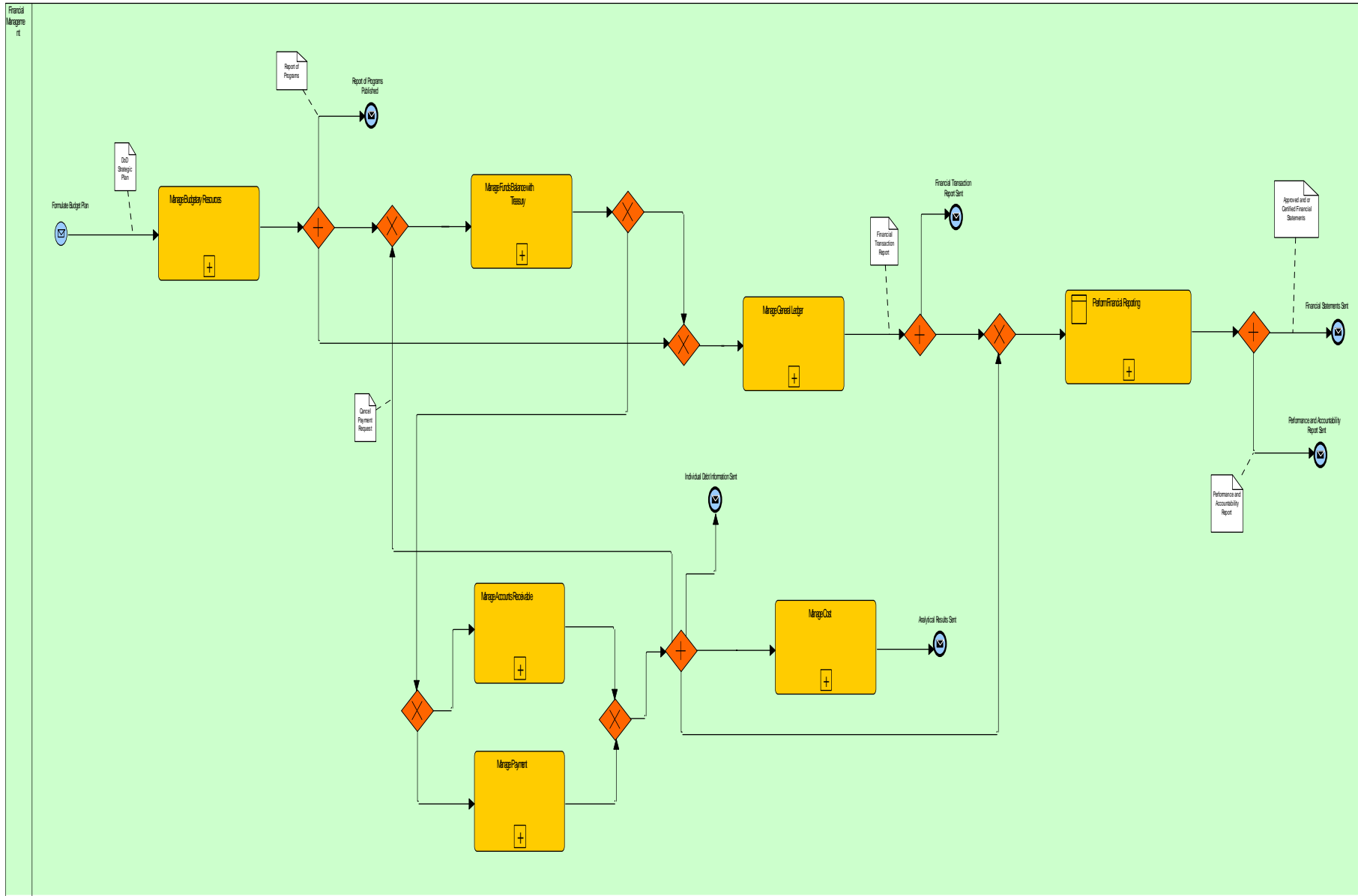

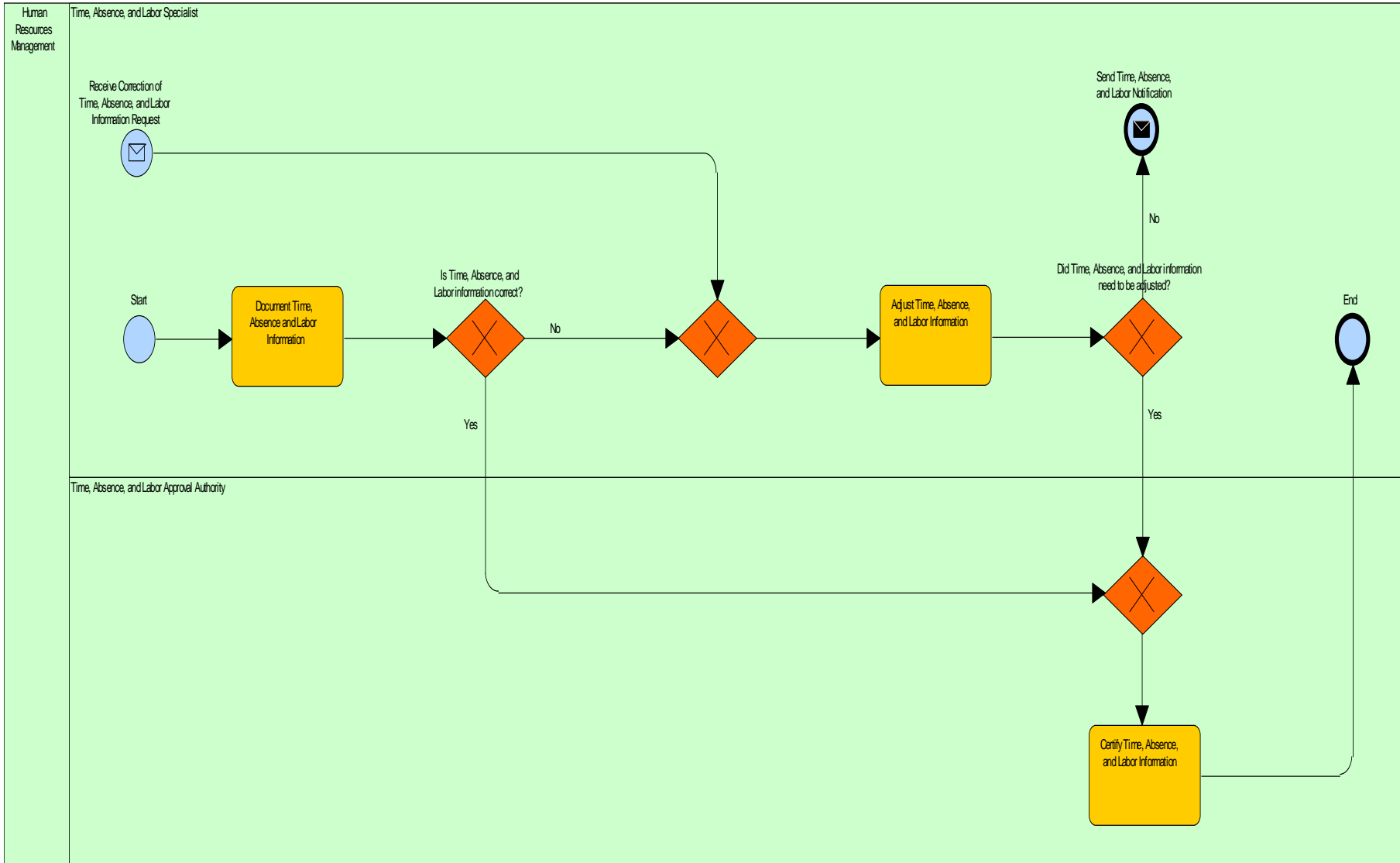

HL Administer Grievance
Process (OV-6c Business
Process)
System Architect

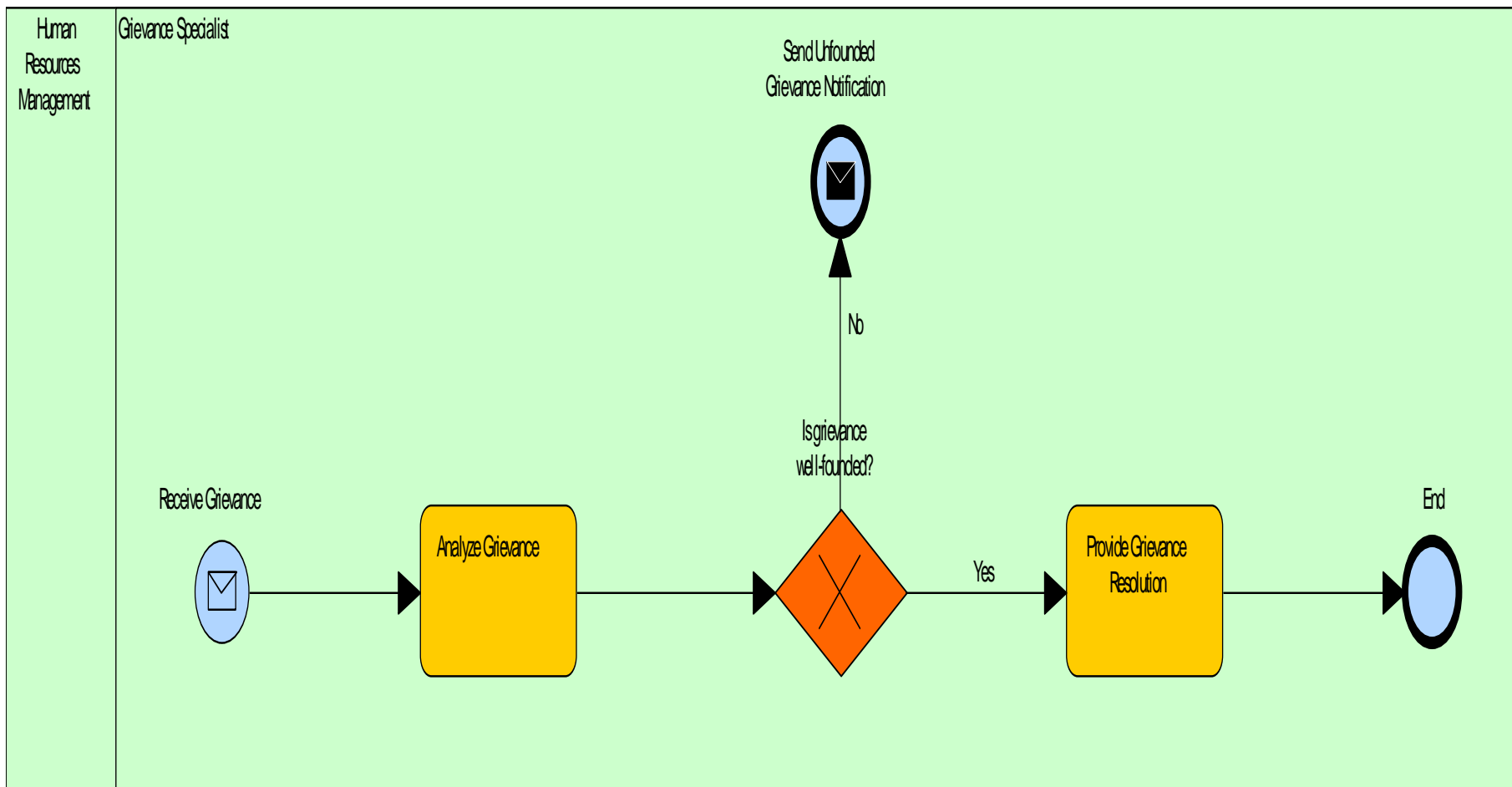

HL Administer Inter-Service Transfer

(OV-6c Business Process)

System Architect

Wednesday, January 09, 2013 2:48 PM

Comment

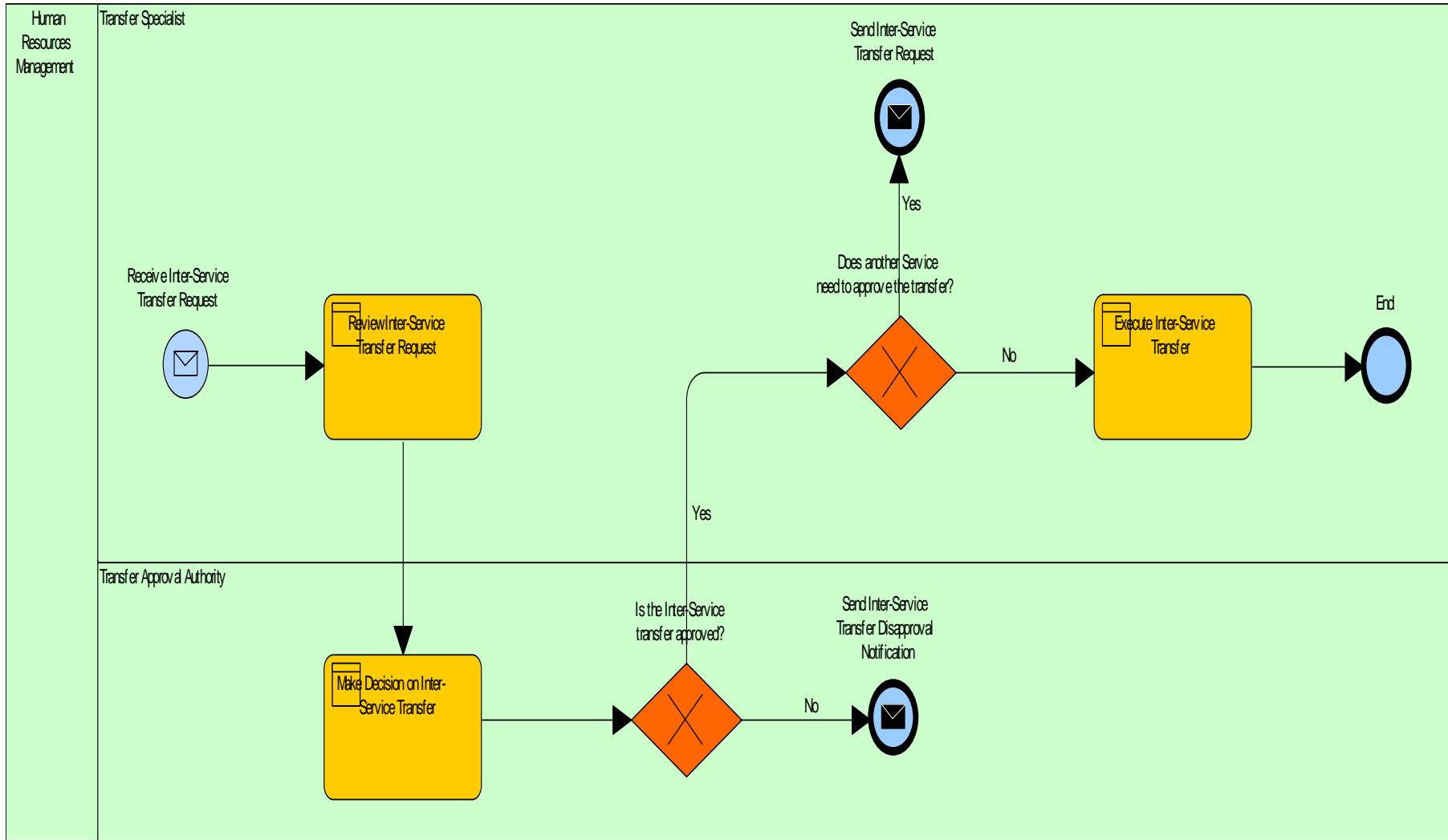

HL Administer Intra-Service Transfer

(OV-6c Business Process)

System Architect

Wednesday, January 09, 2013 2:48 PM

Comment

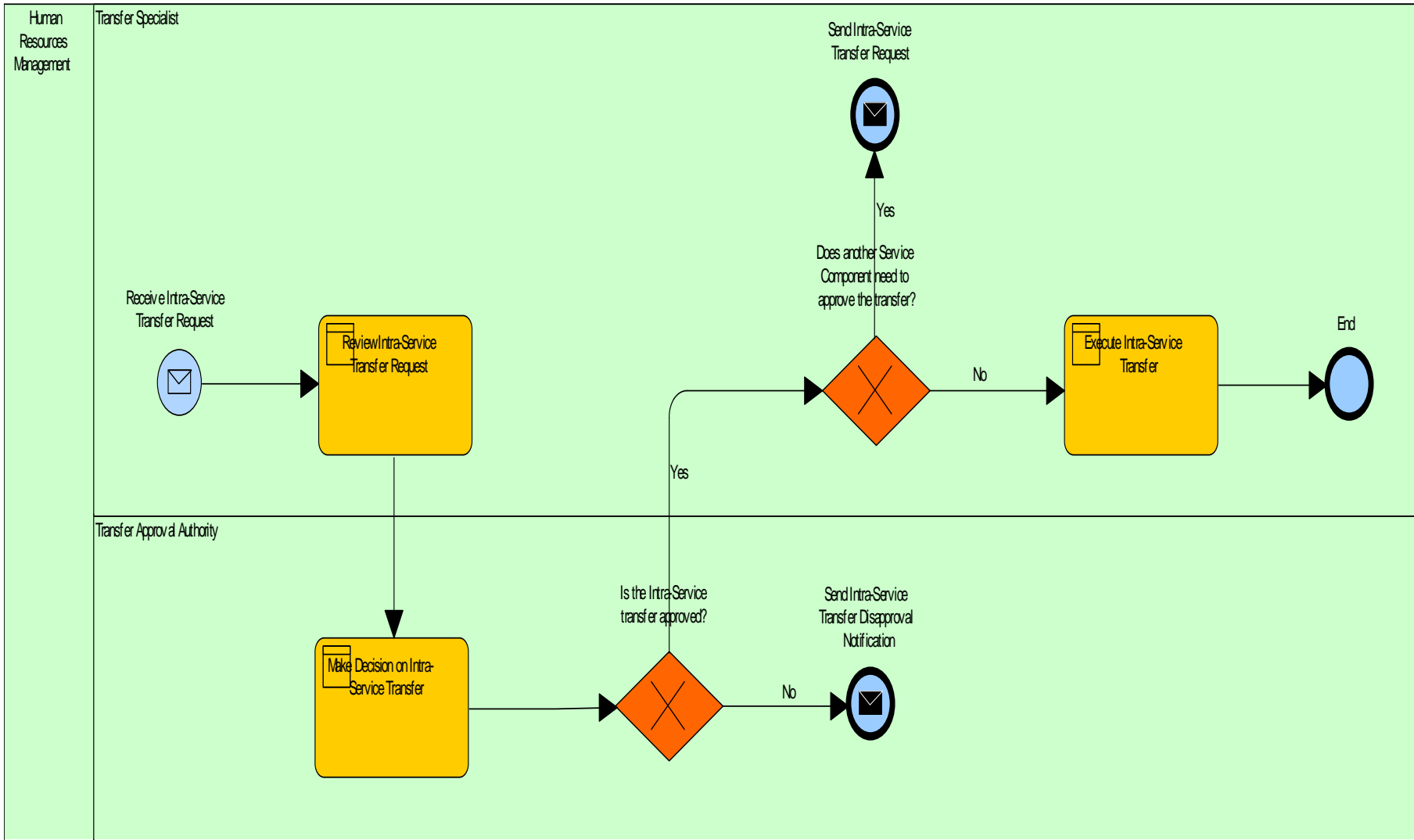

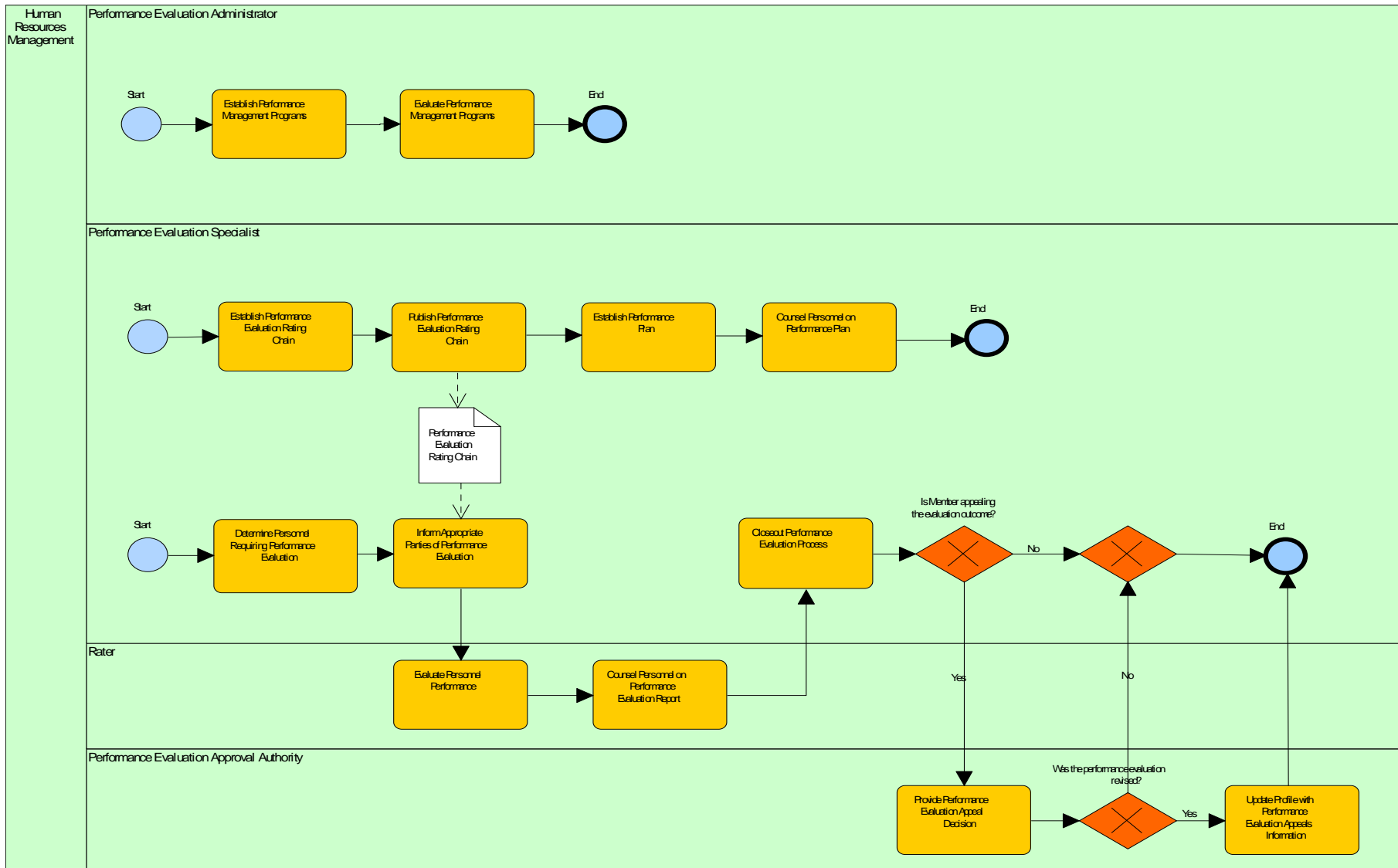

HL Administer Physical
Fitness Program(OV-6c
Business Process)
System Architect
Wednesday, January 09,

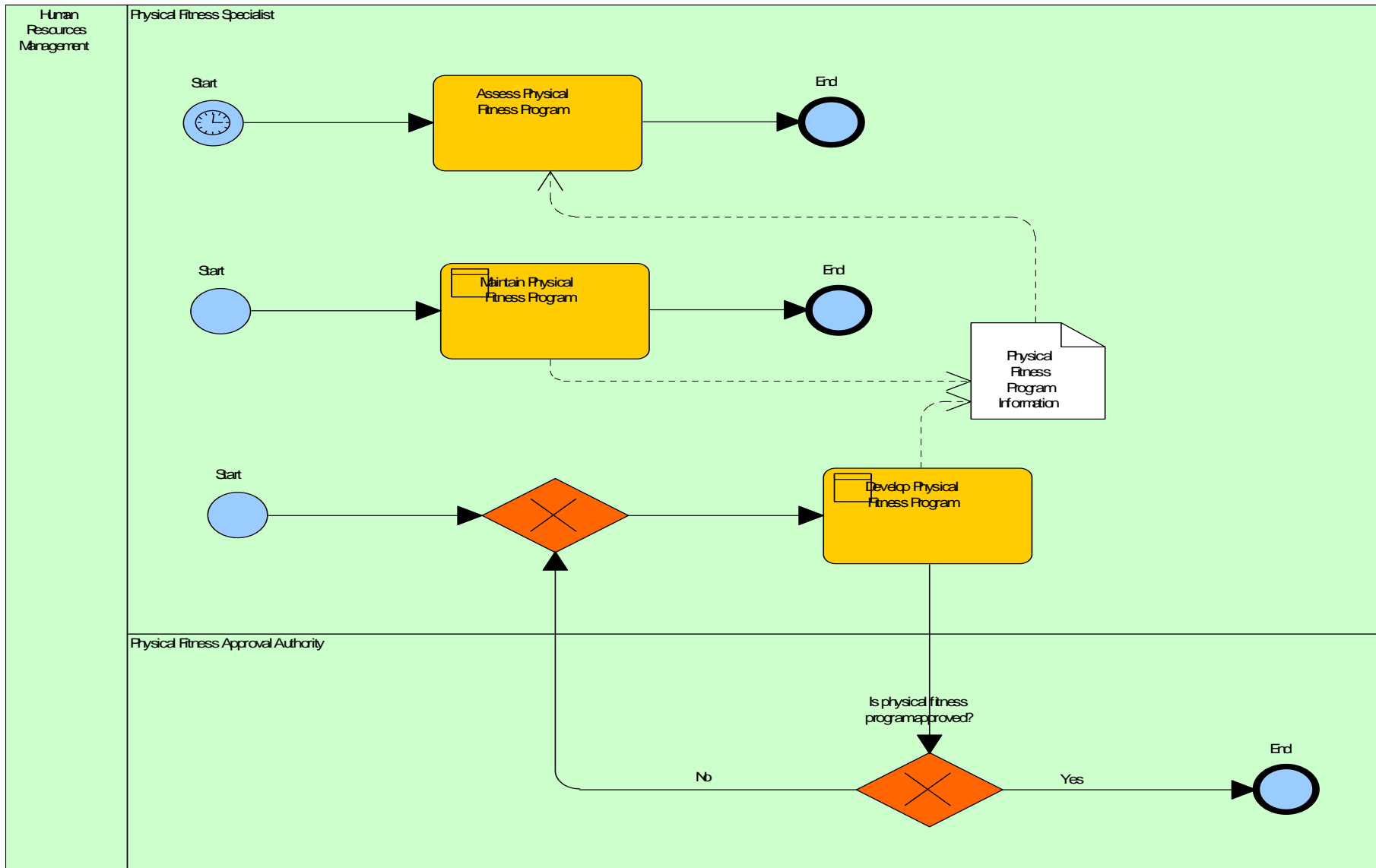

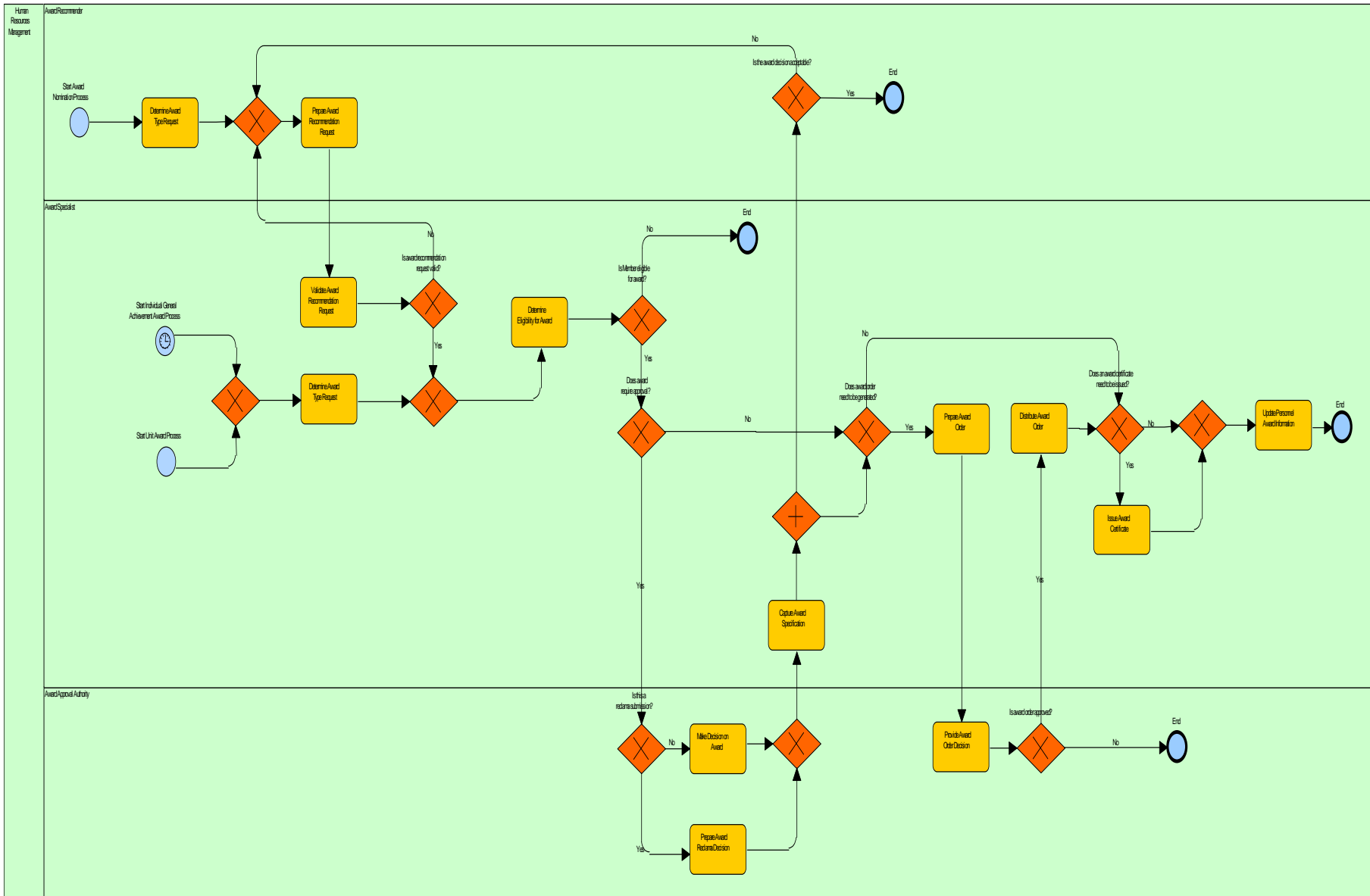

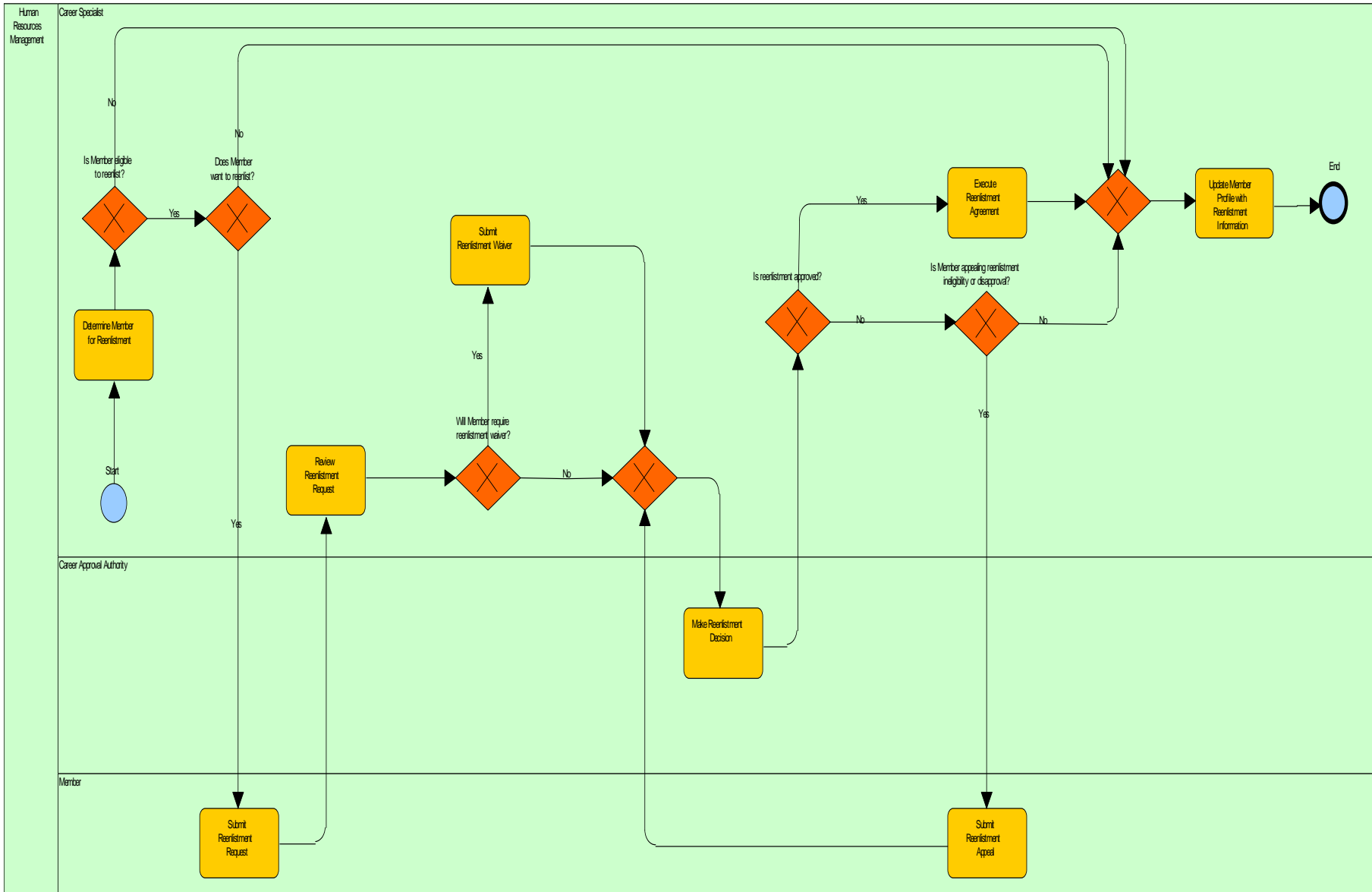

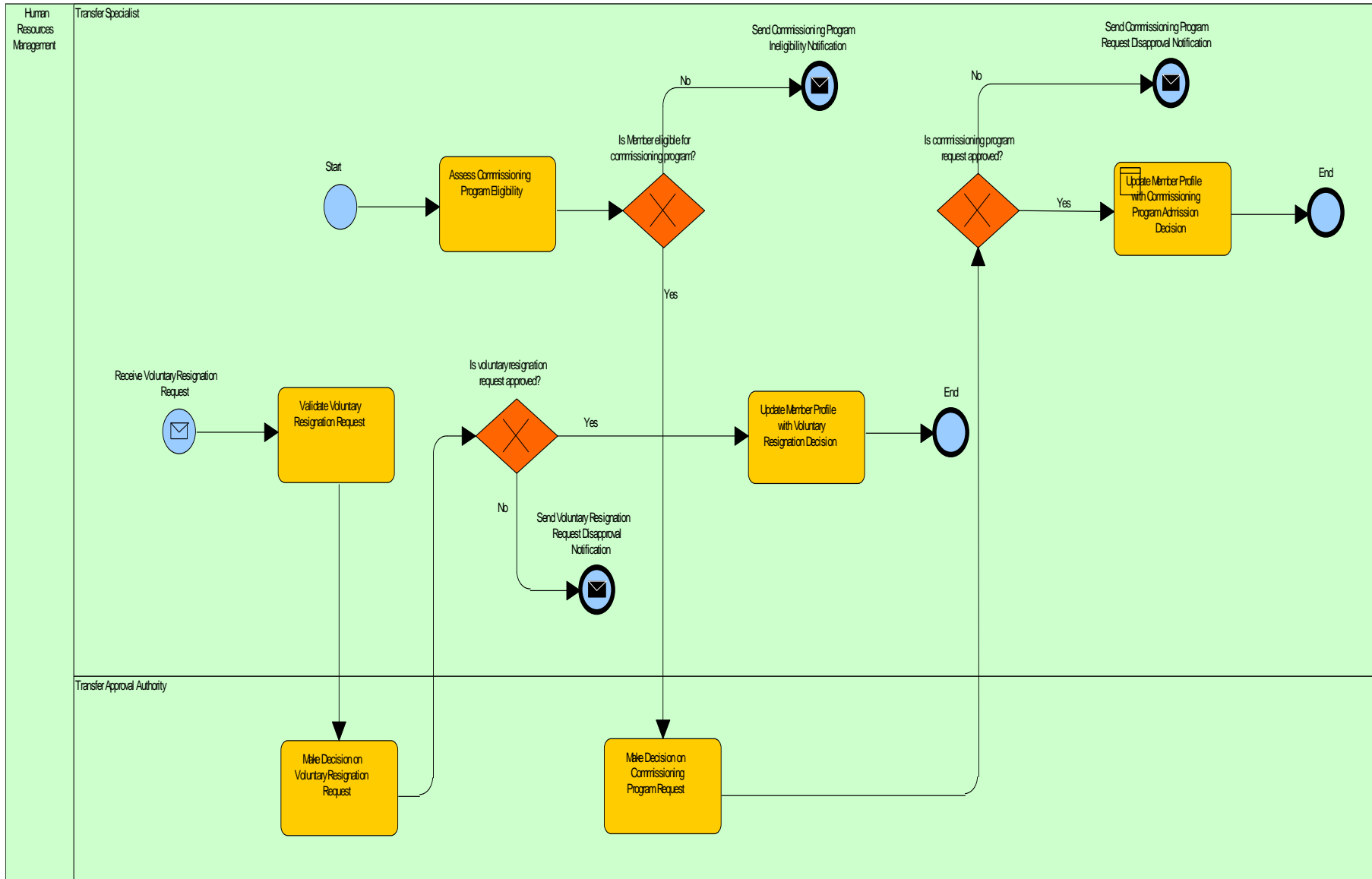

HL Administer Transfer To and From
Active Duty (OV-6c Business Process)

System Architect

Wednesday, January 09, 2013 3:06

PM

Comment

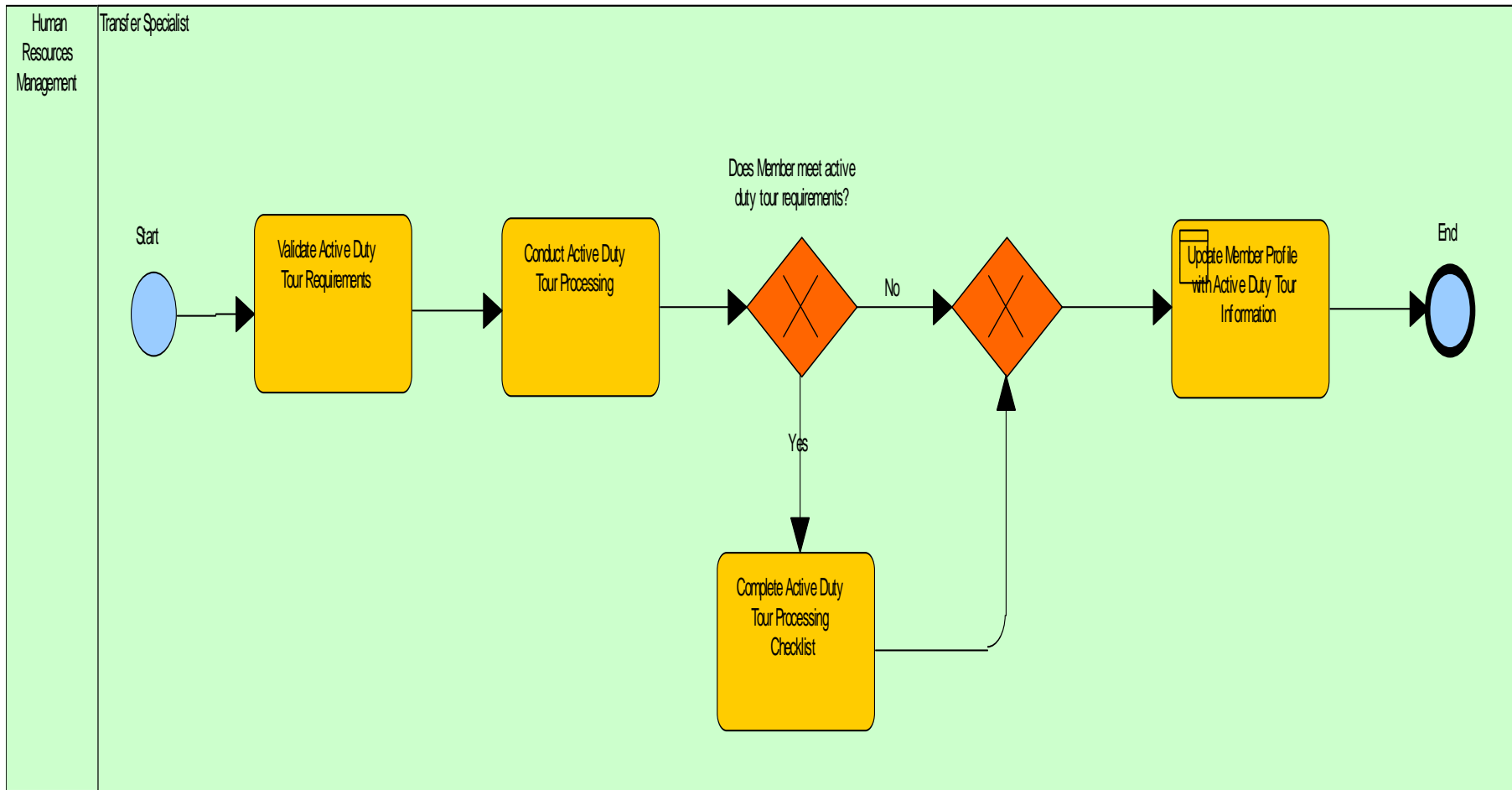

HL Generate Personnel
Grade Change Order (OV-6c
Business Process)
System Architect
Friday, January 11, 2013

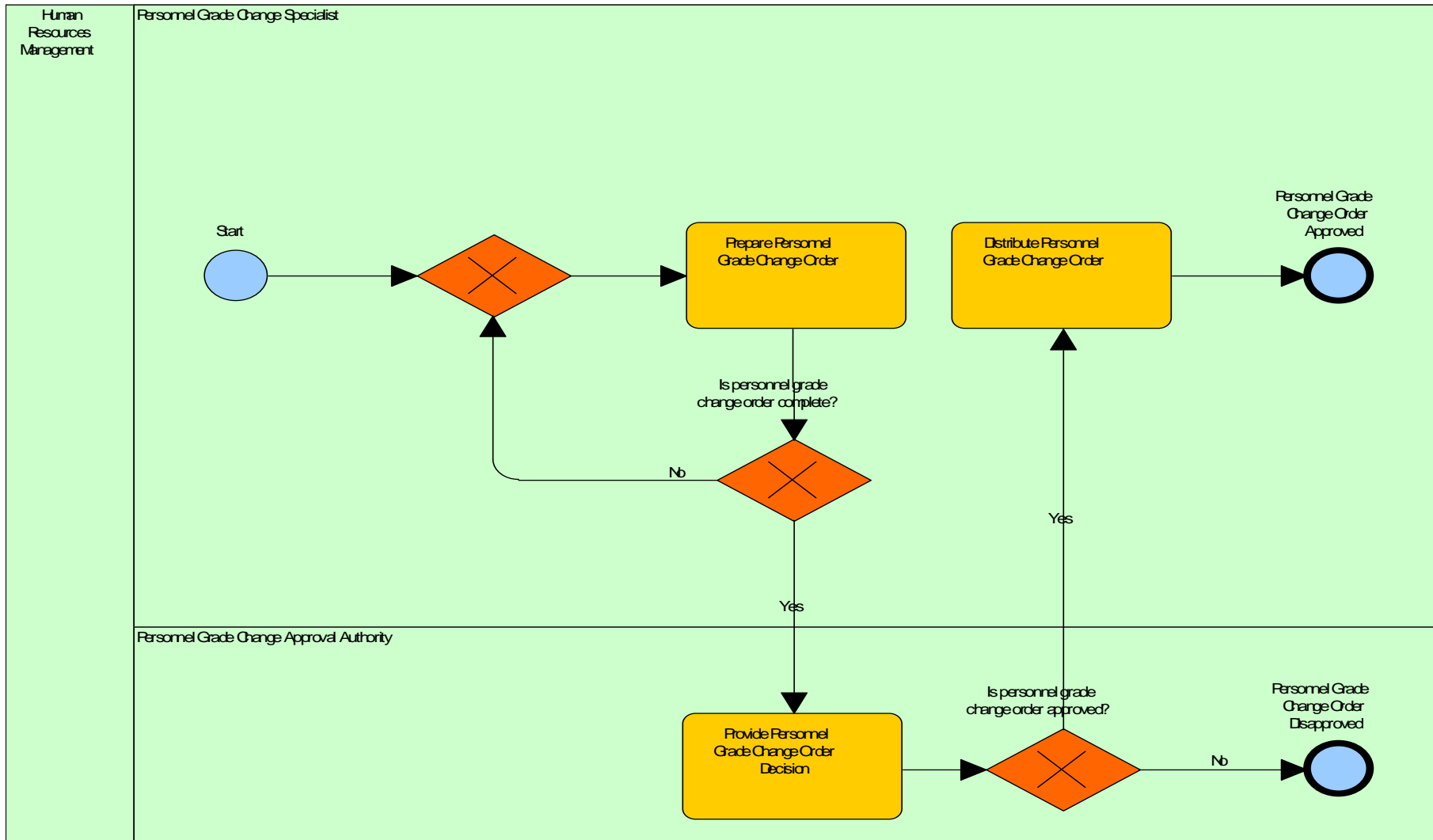

HL Manage Access to Healthcare
(OV-6c Business Process)
System Architect
Wednesday, January 09, 2013
3:08 PM

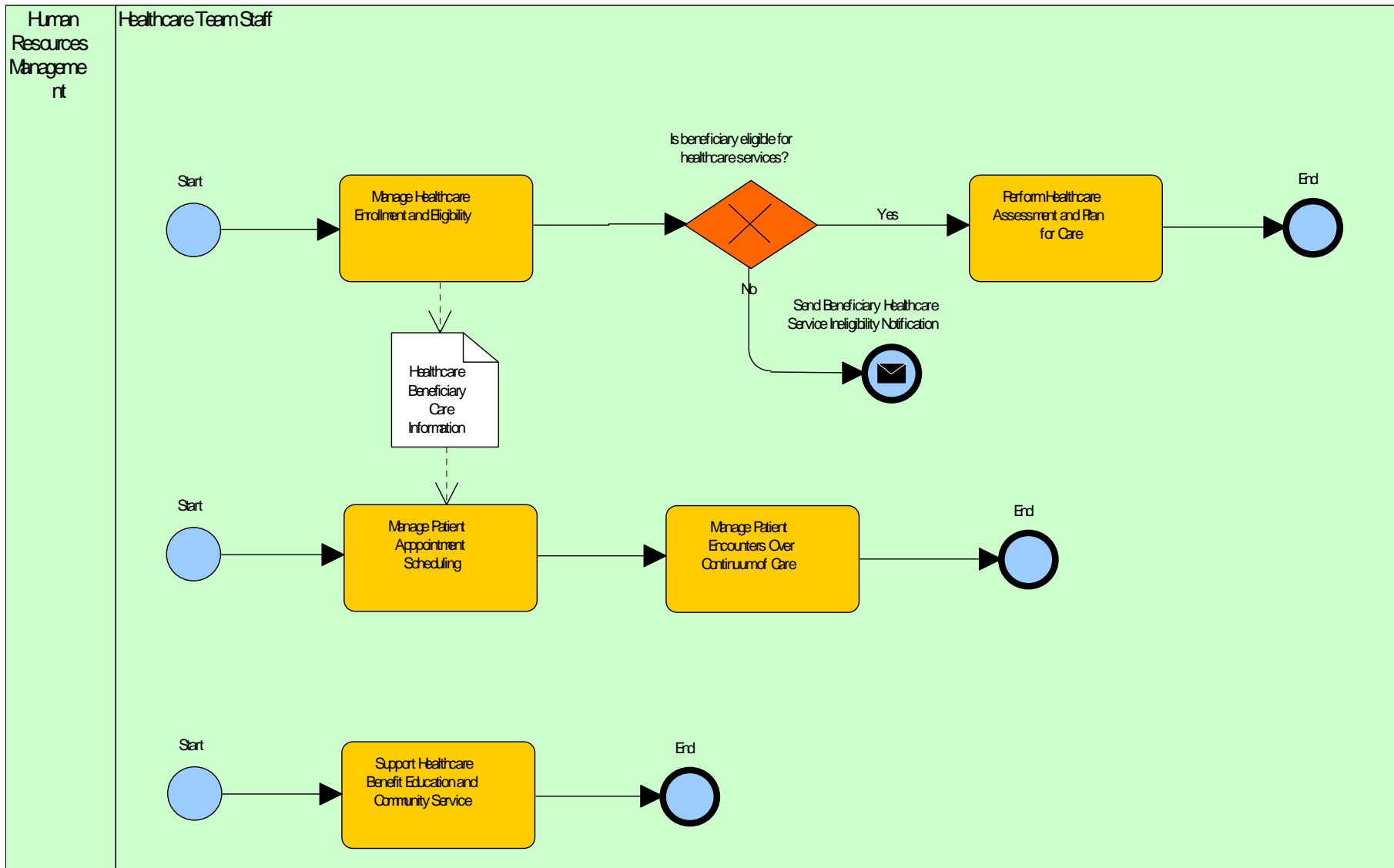

HL Manage Adverse Actions (OV-6c Business Process)

System Architect

Wednesday, January 09, 2013

3:10 PM

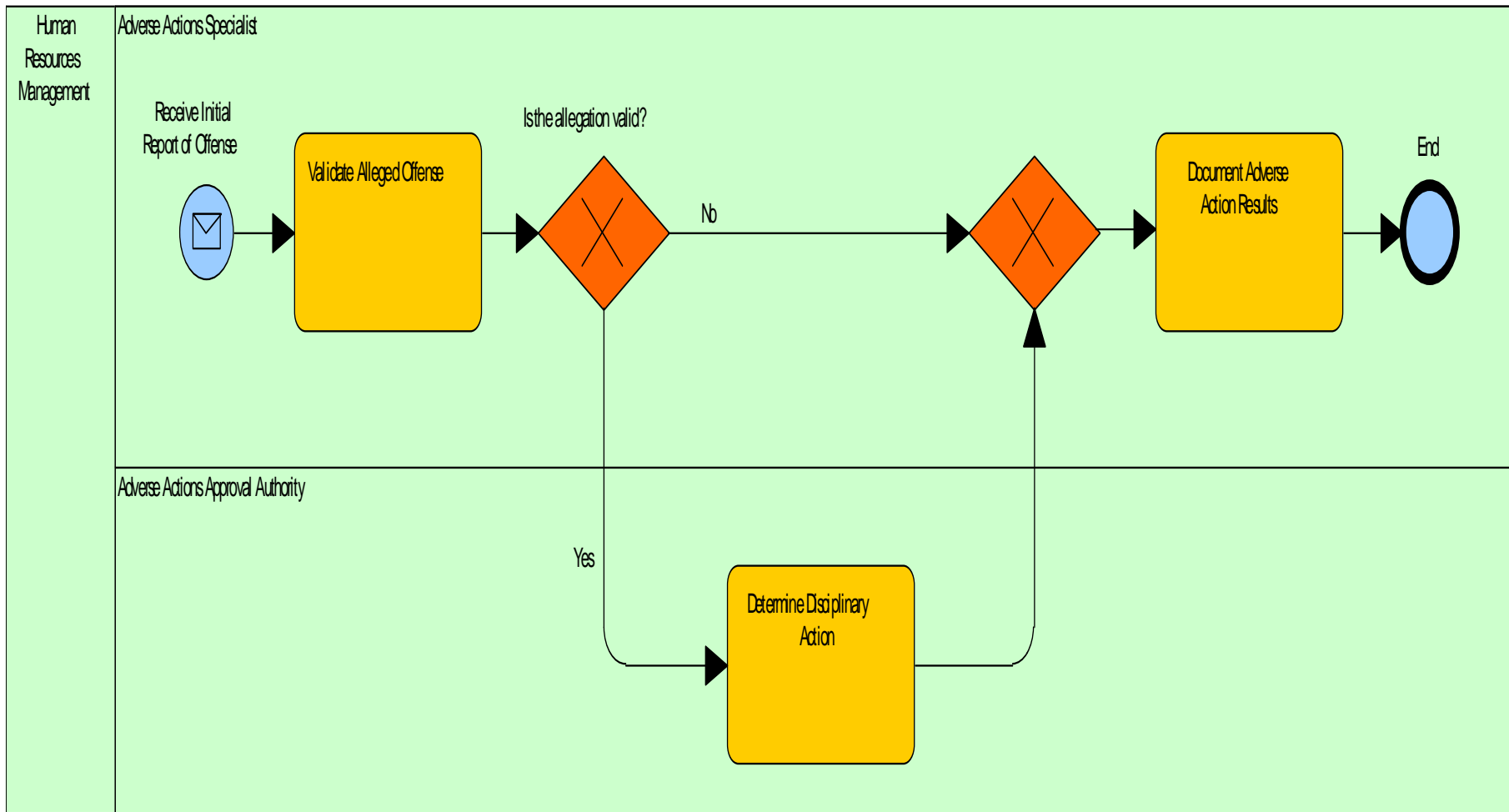

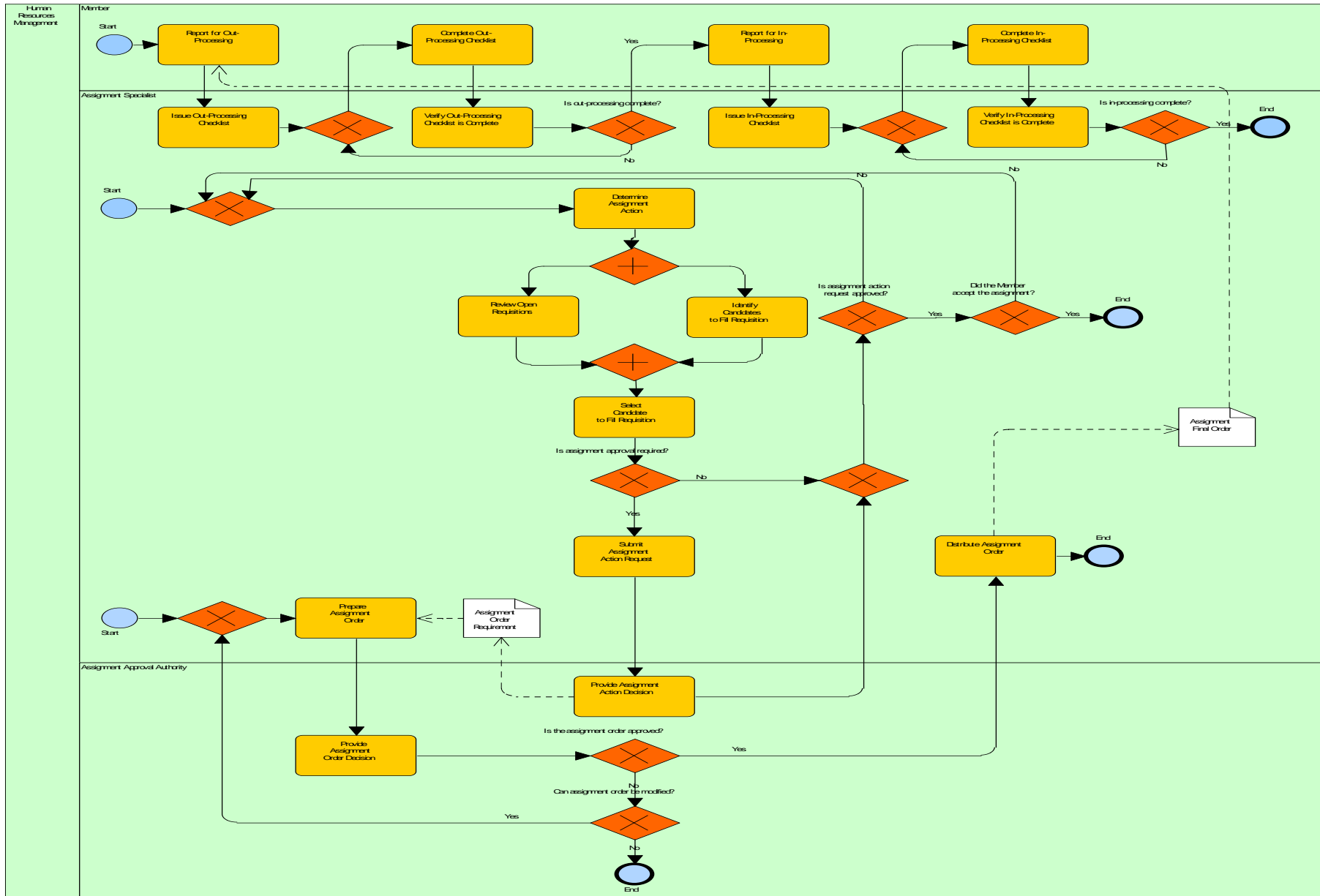

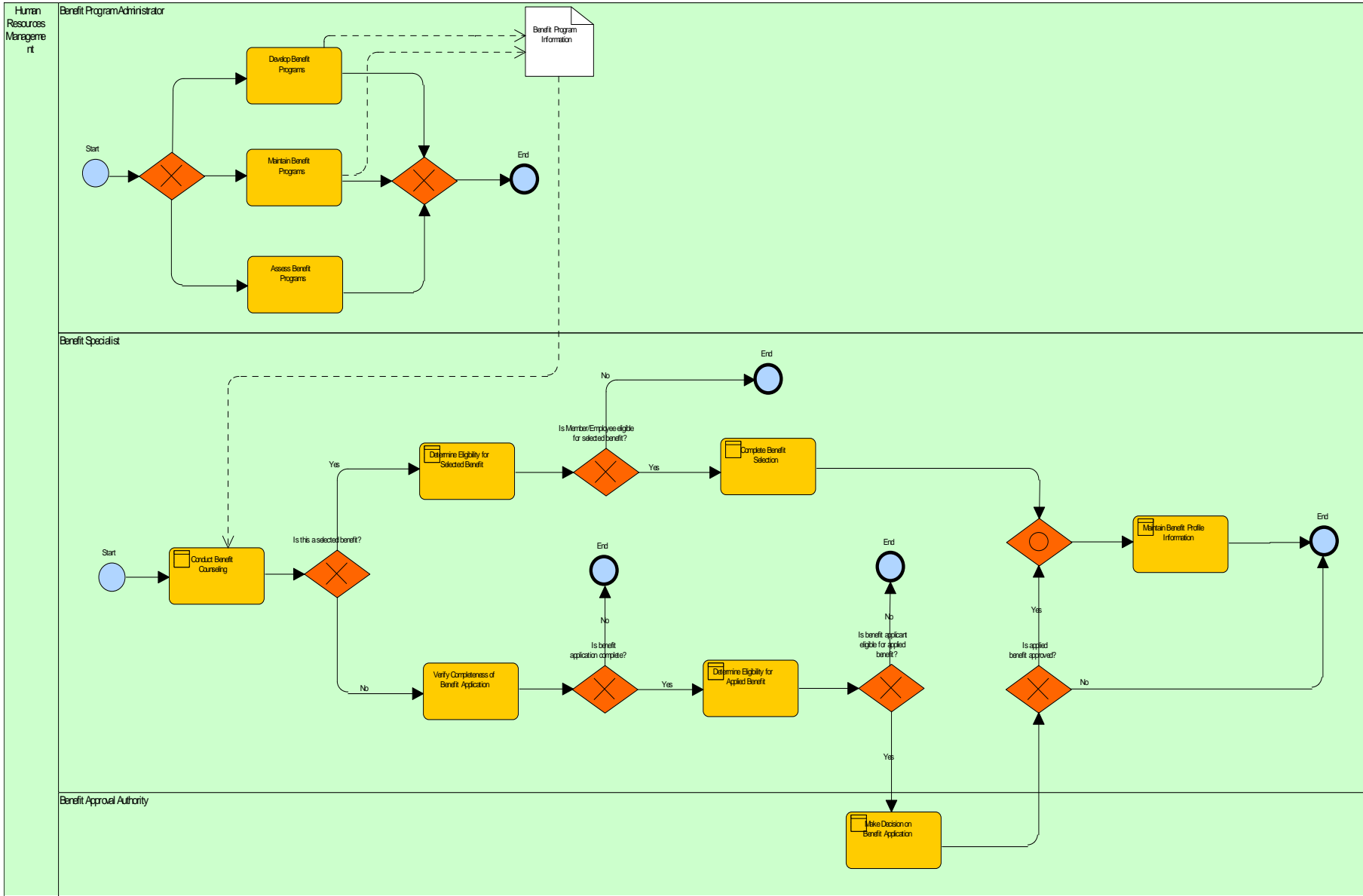

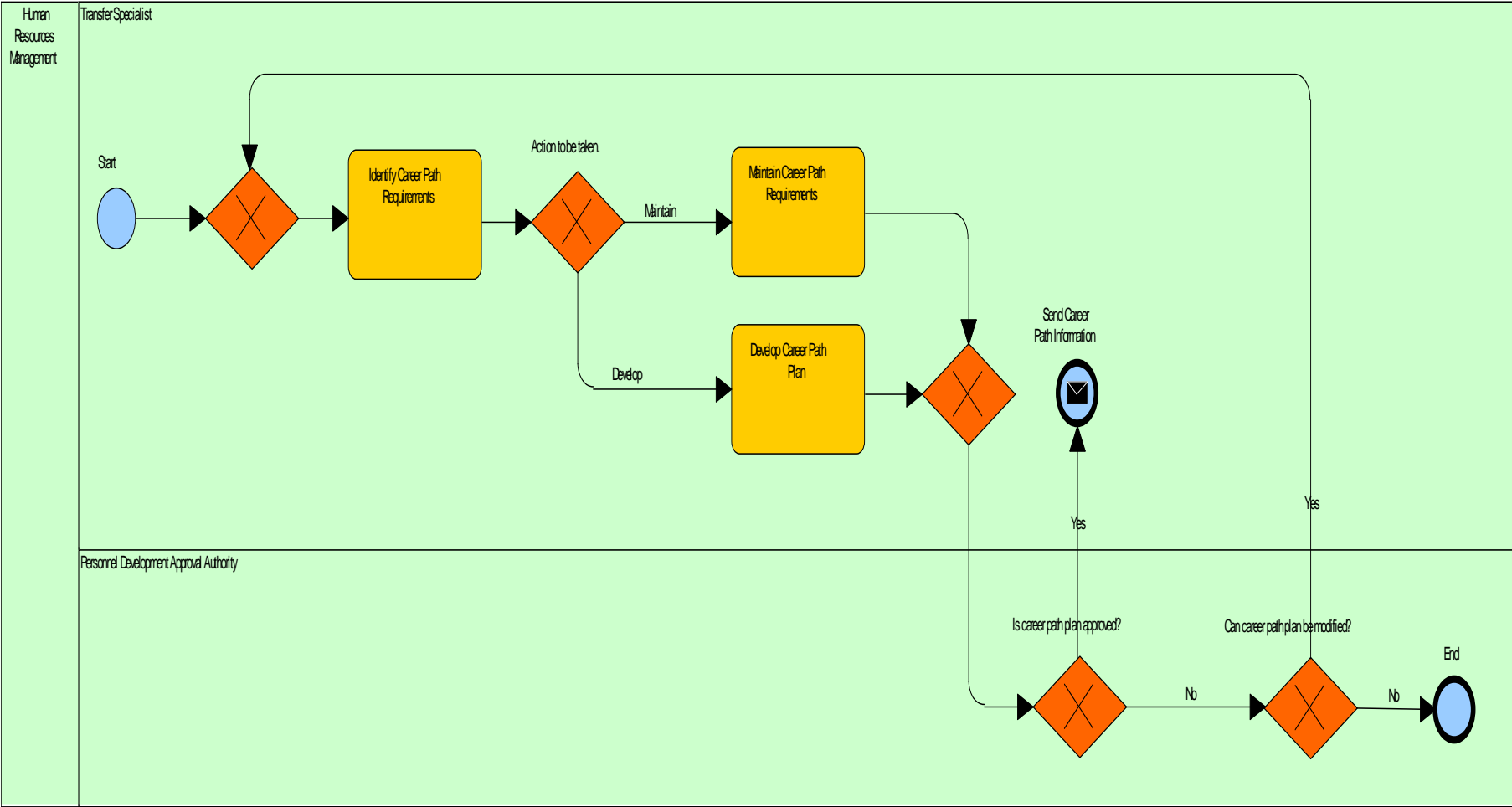

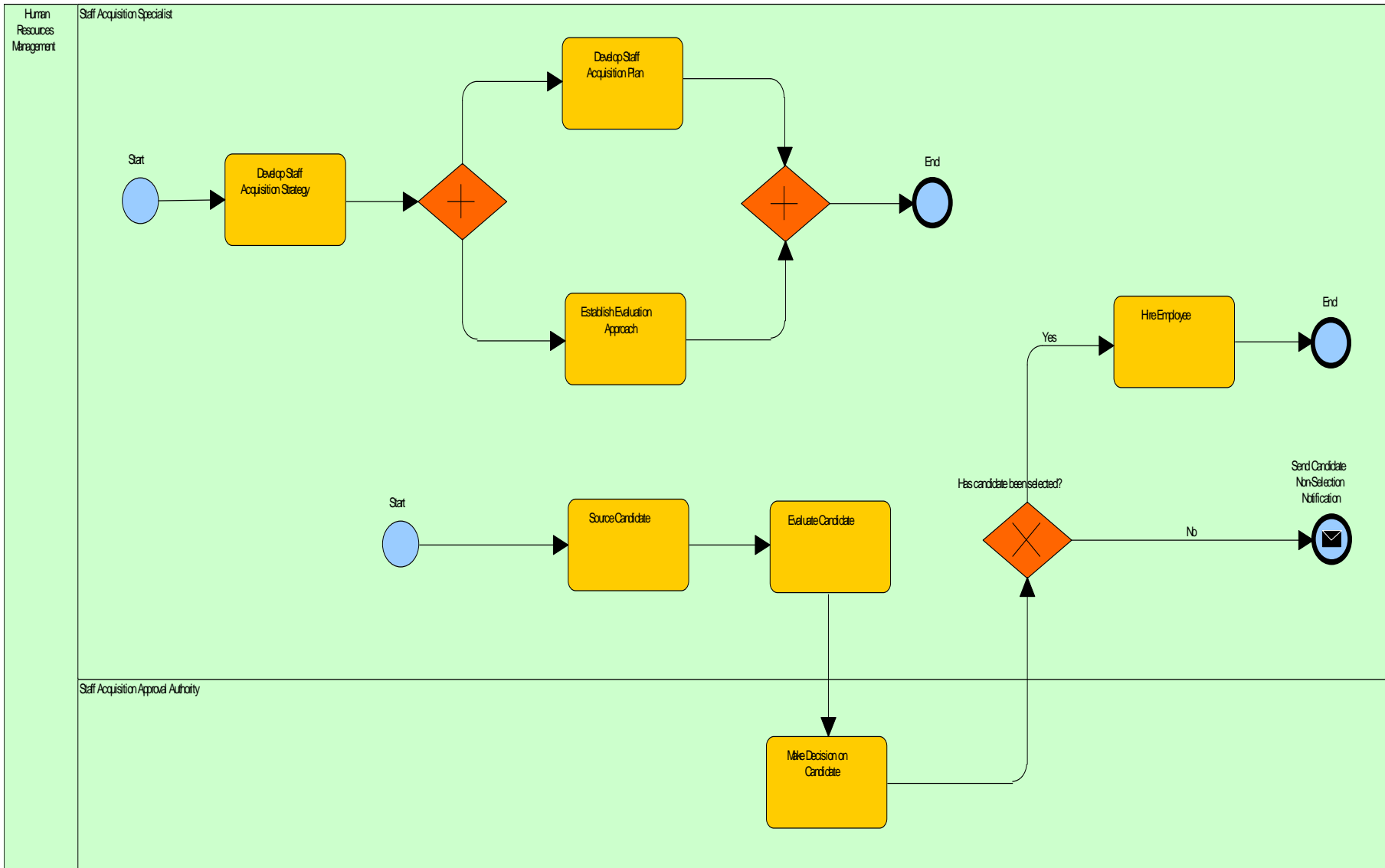

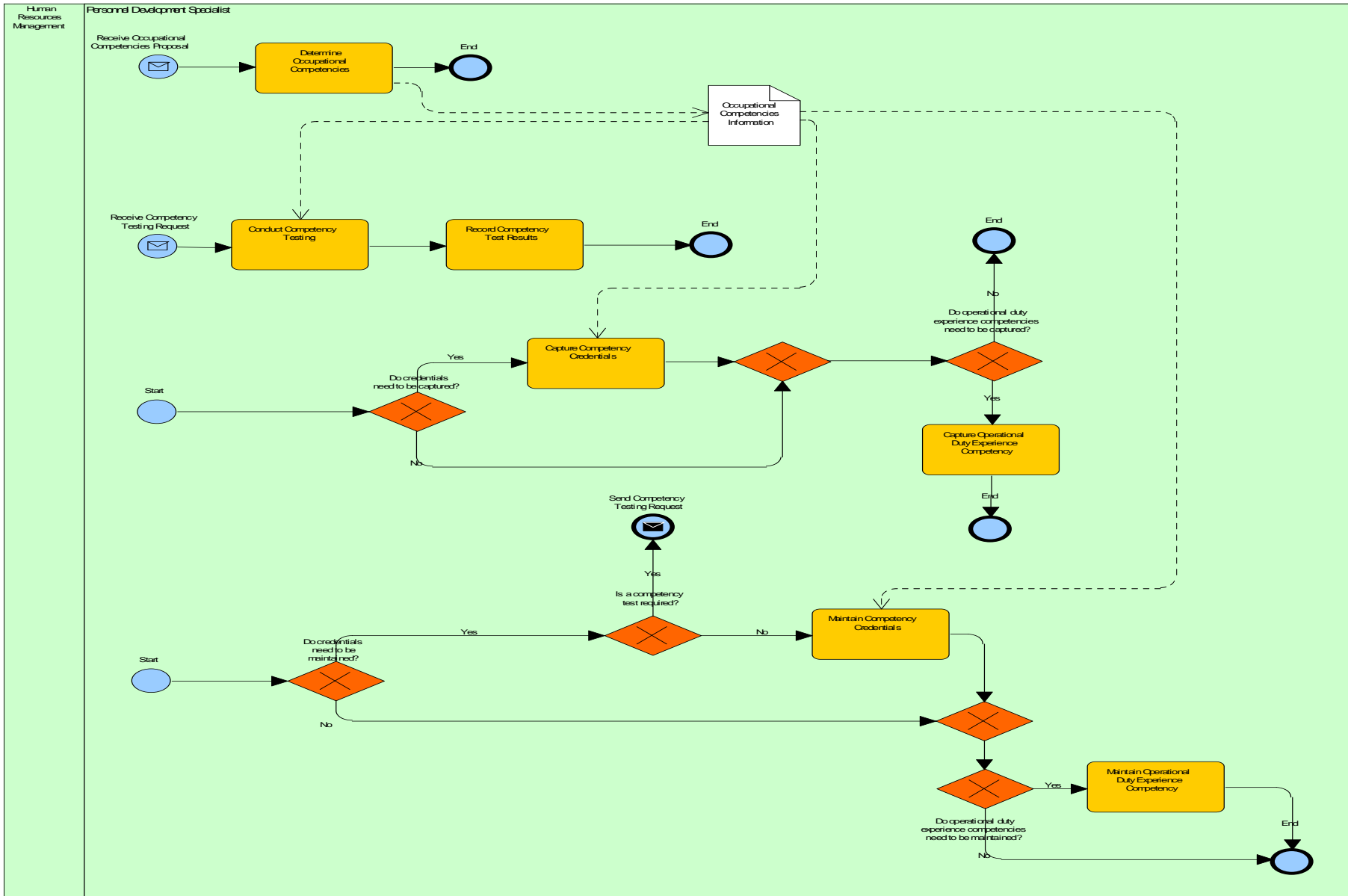

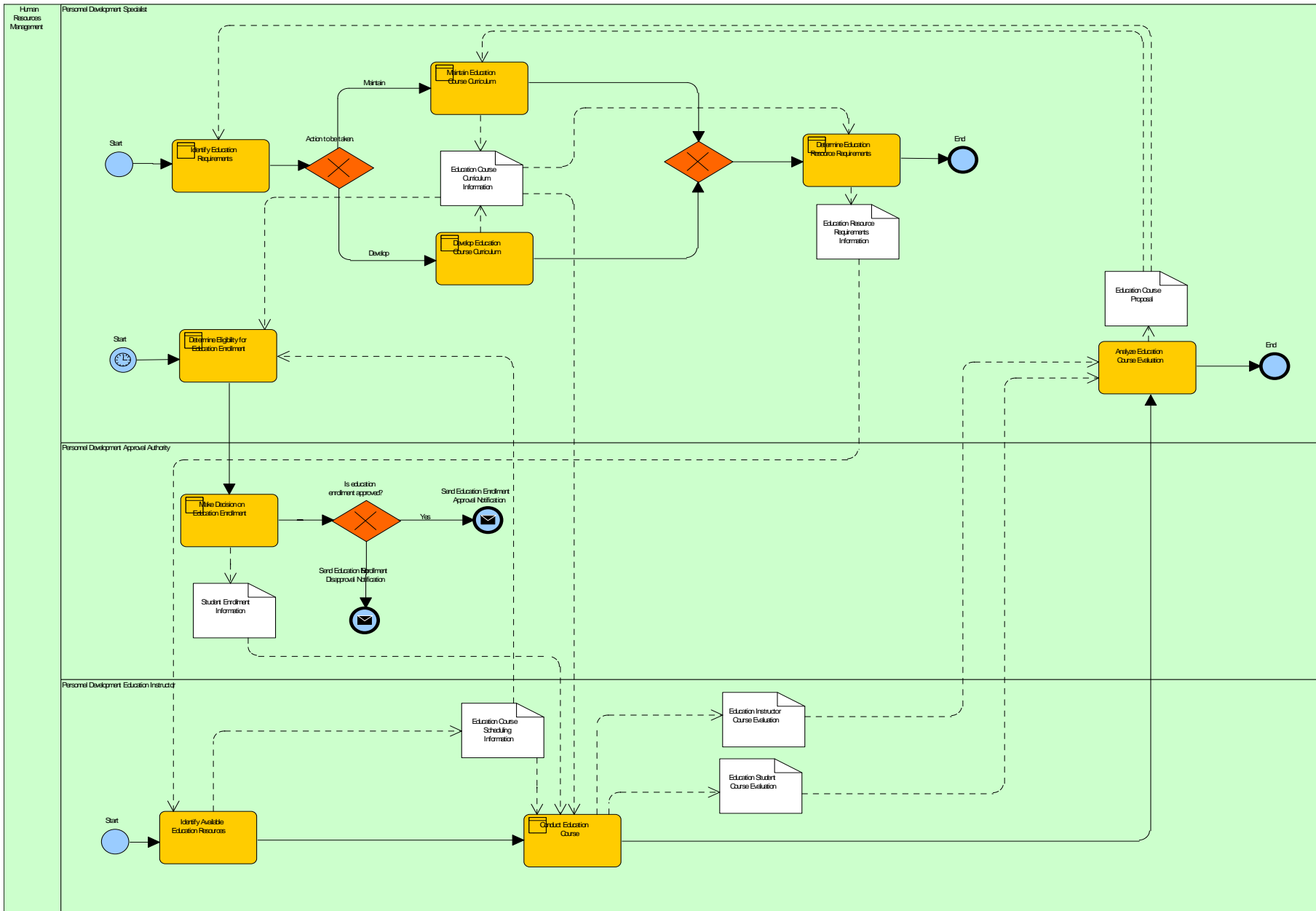

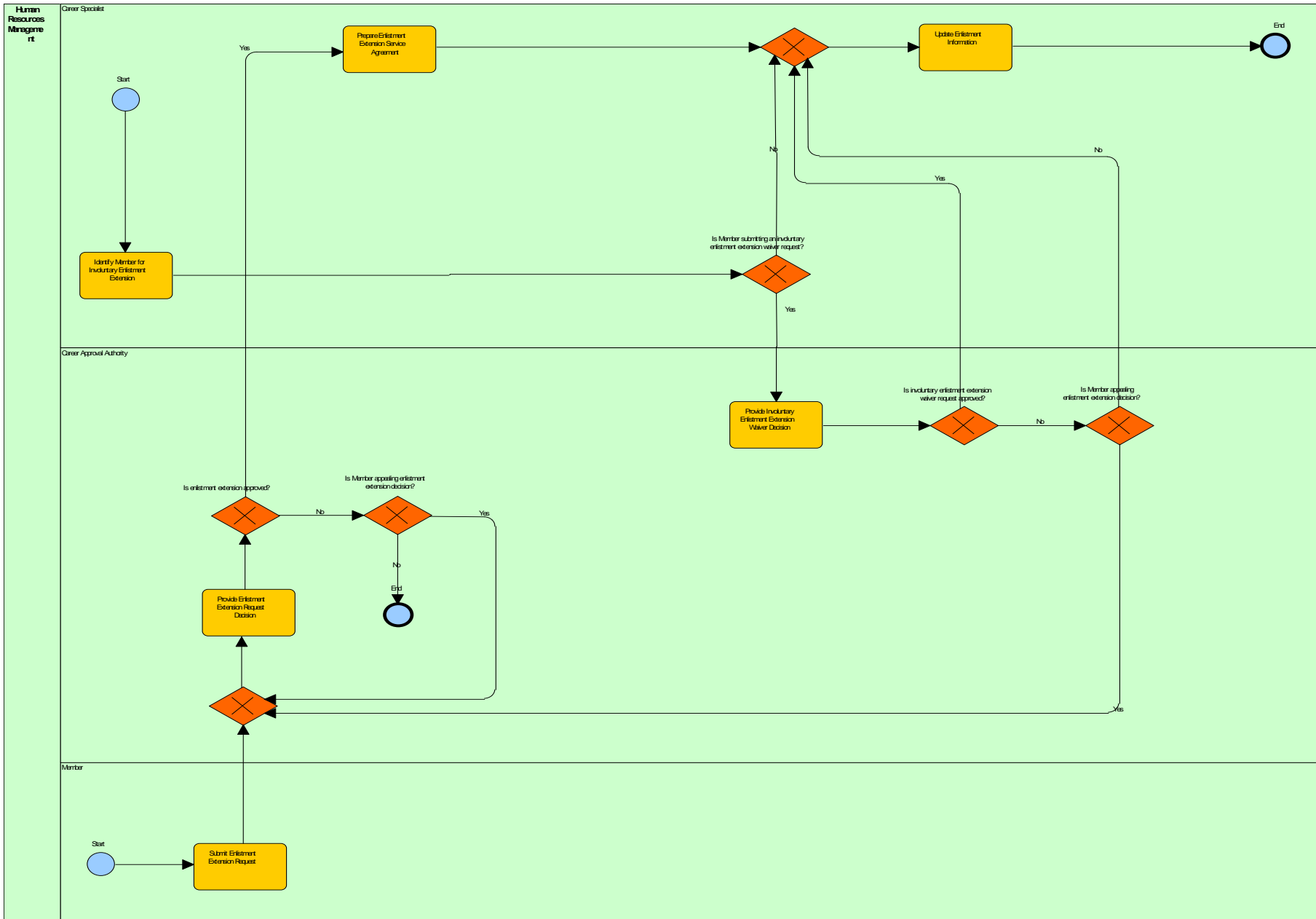

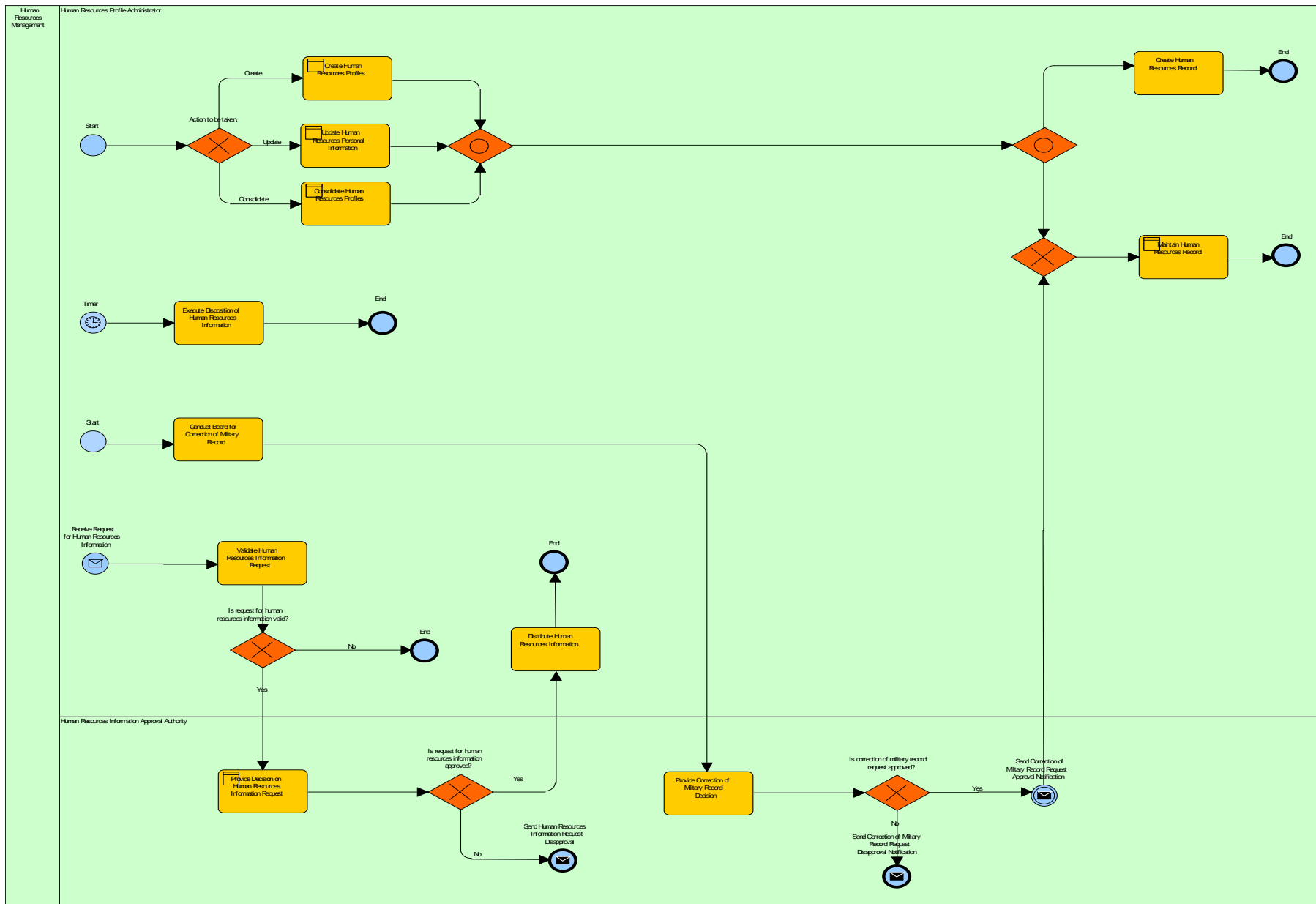

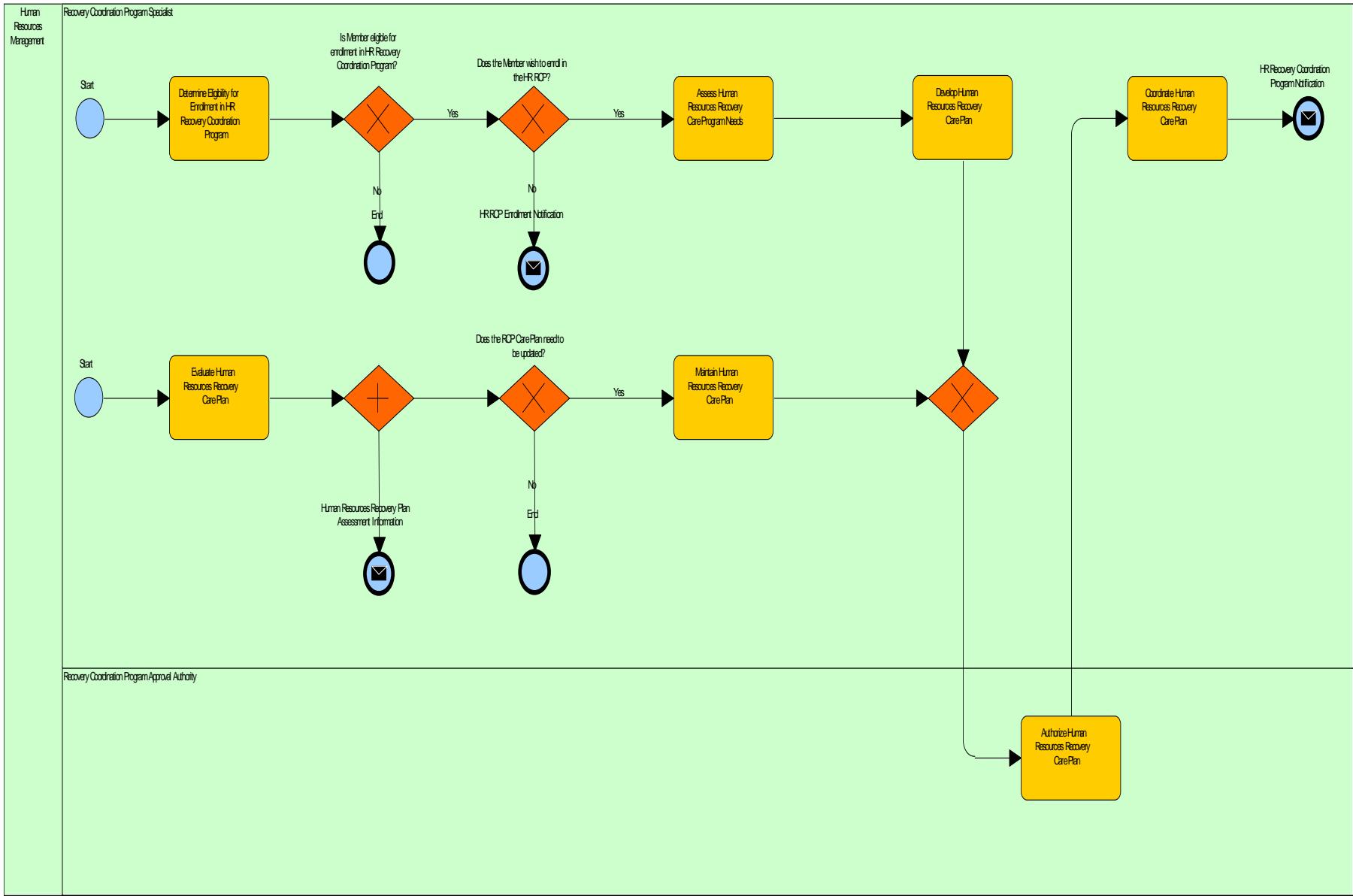

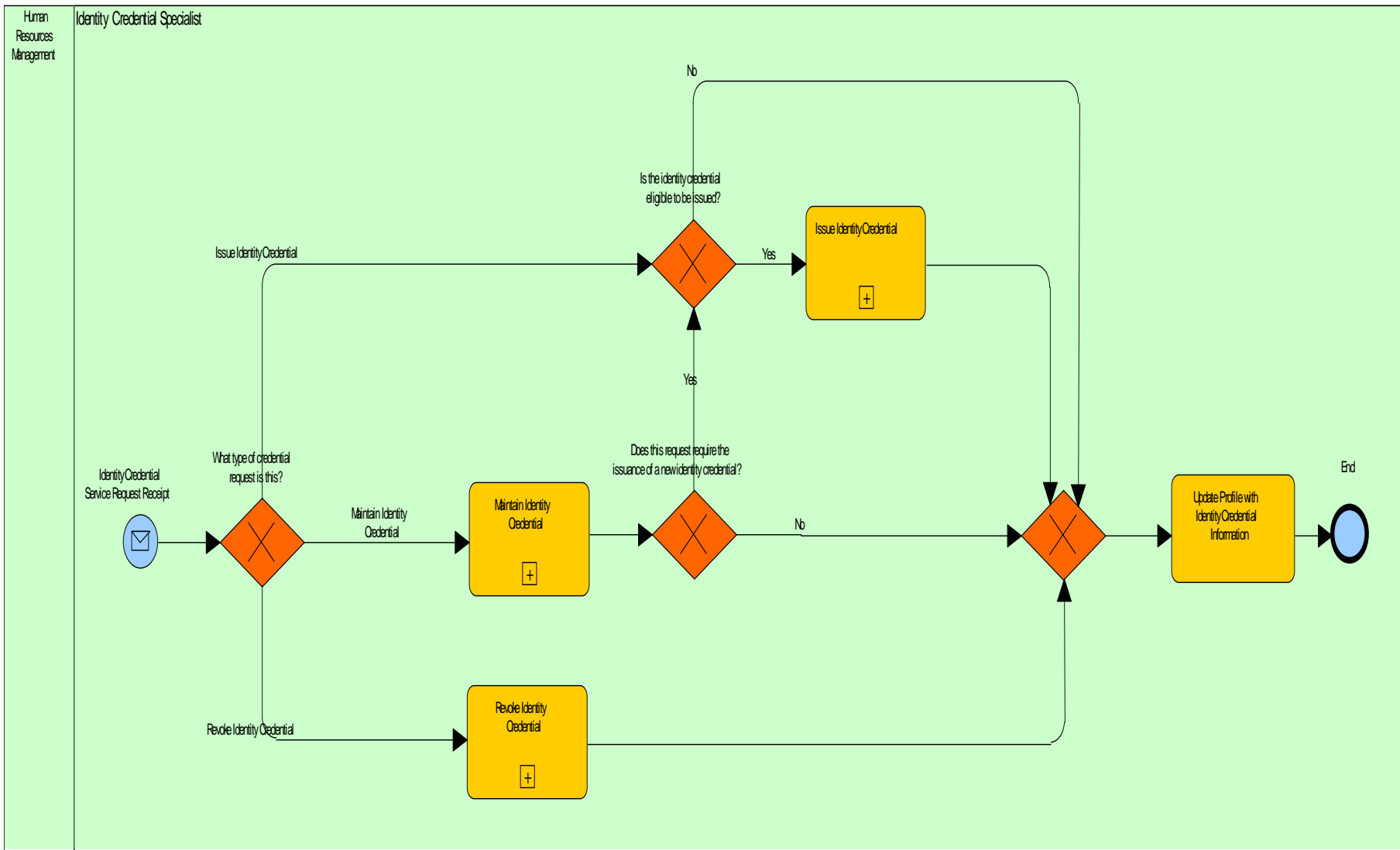

HL Manage Individual Development Plan (OV-6c Business Process)
System Architect
Thursday, January 10, 2013 10:28 AM

Comment

Human Resources Management

Personnel Development Specialist

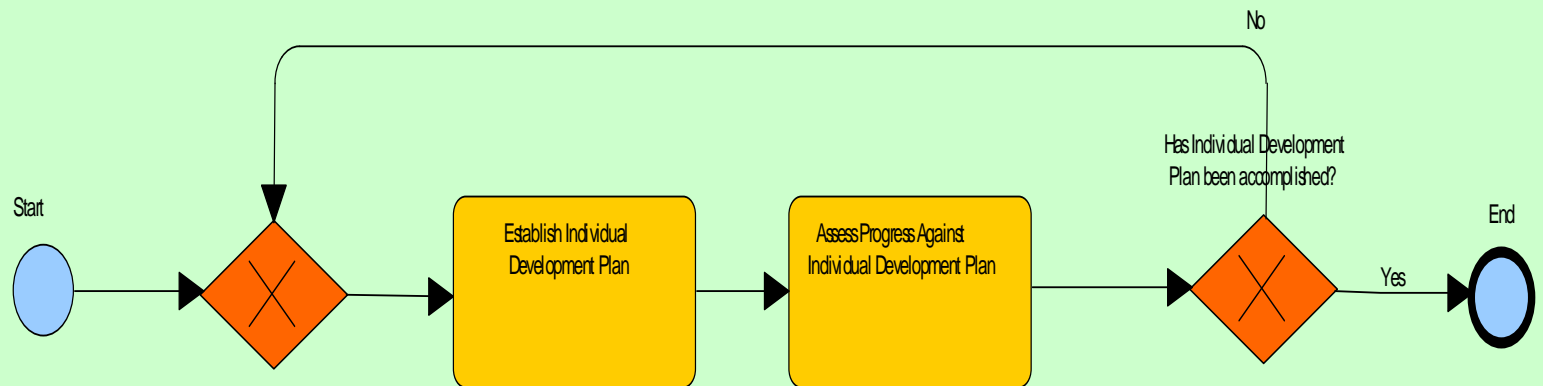

HL Manage Individual Training Course (OV-6c Business Process)

System Architect

Thursday, January 10, 2013 10:27 AM

Omnet

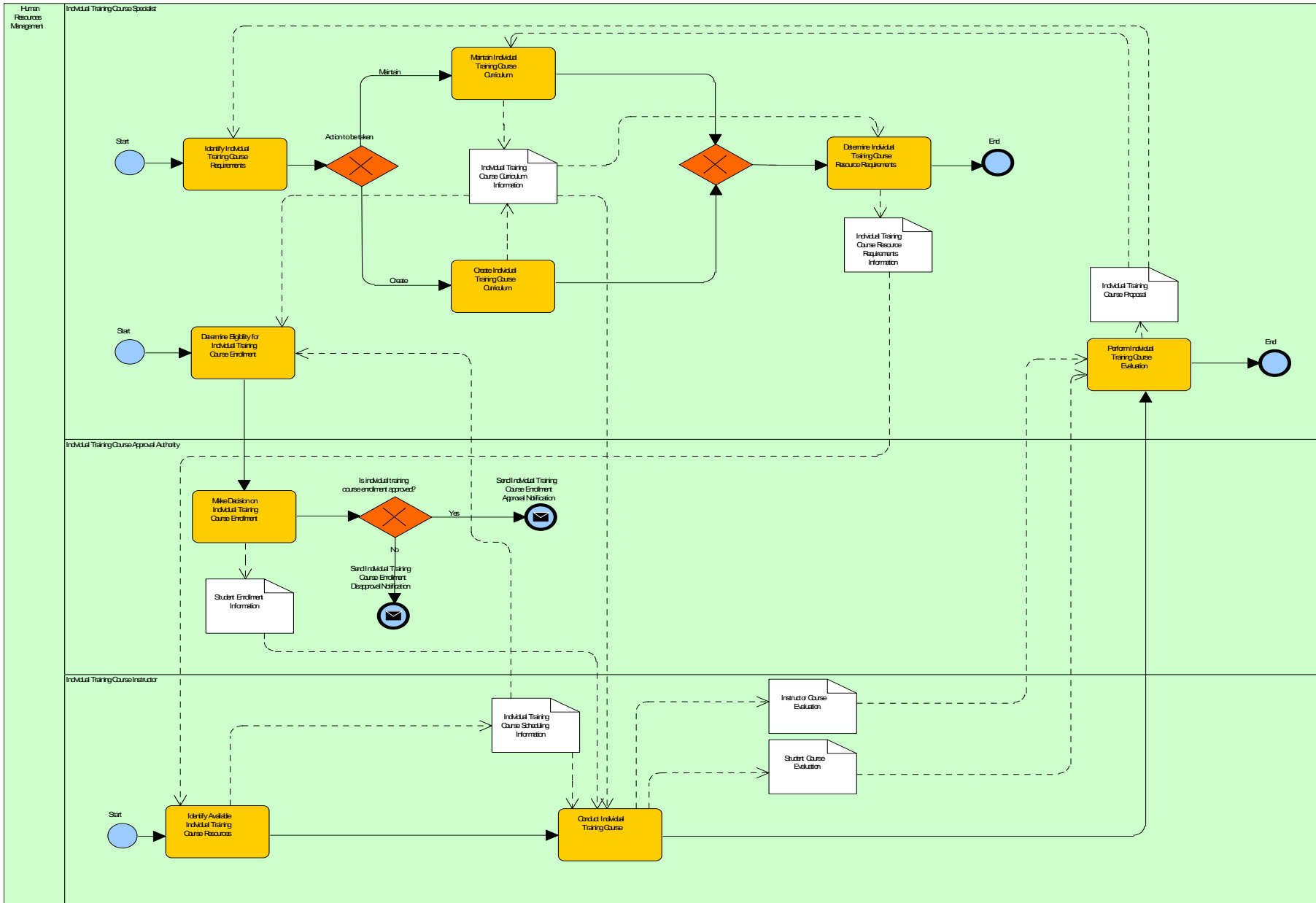

HL Manage Labor Relations (O/V-GC Business Process)

System Architect

Thursday, January 10, 2013 10:27 AM

Comment

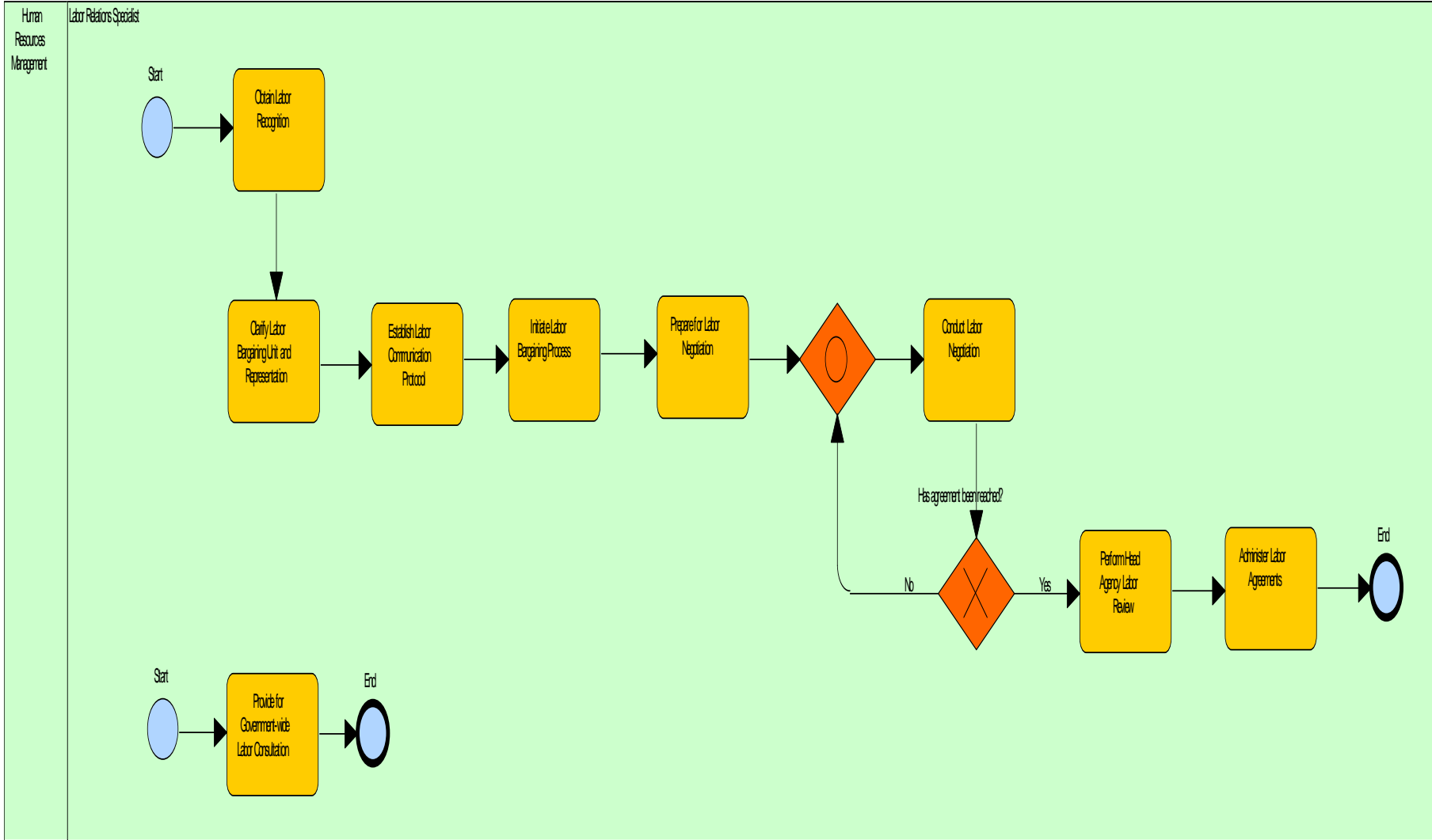

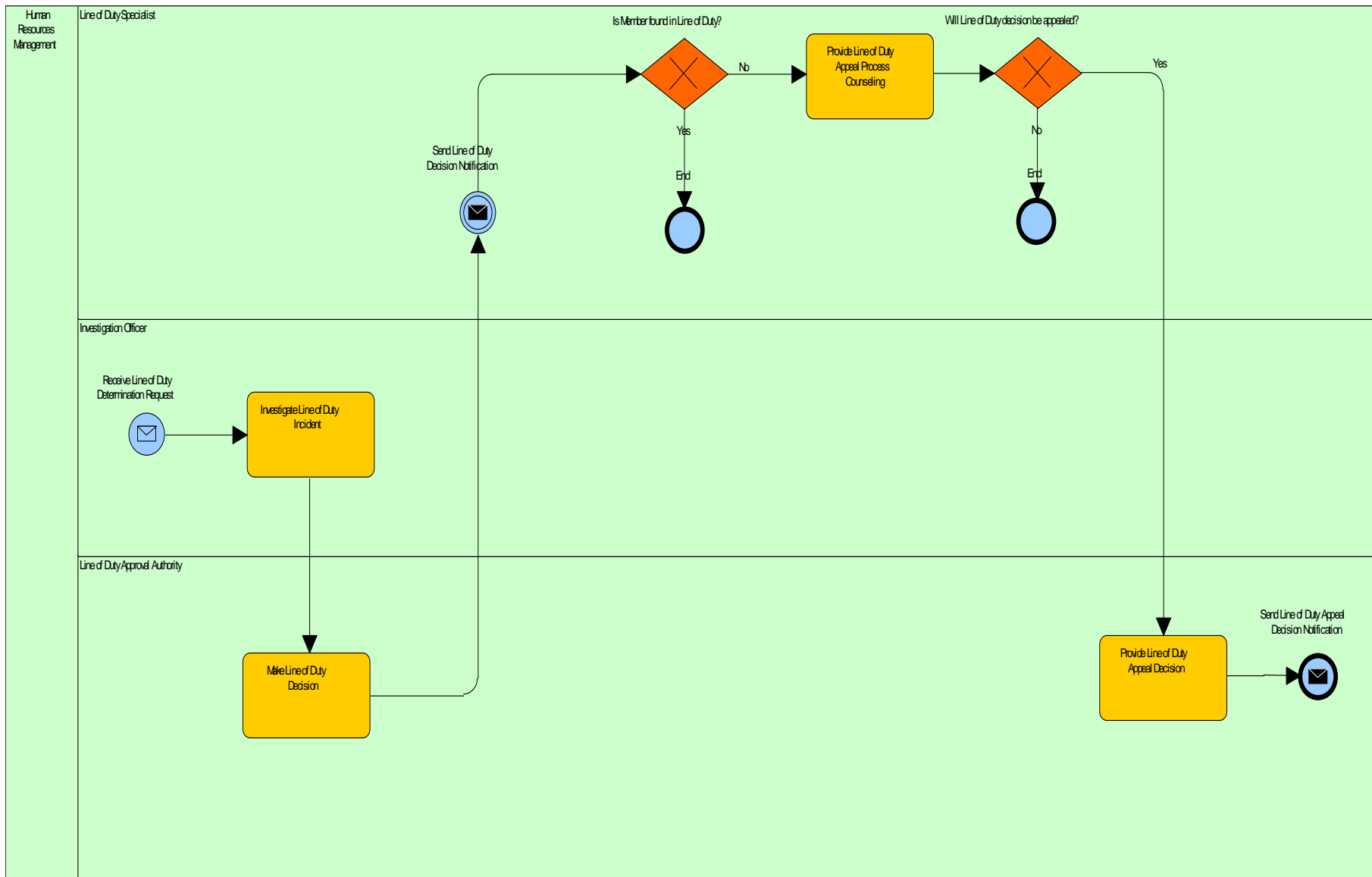

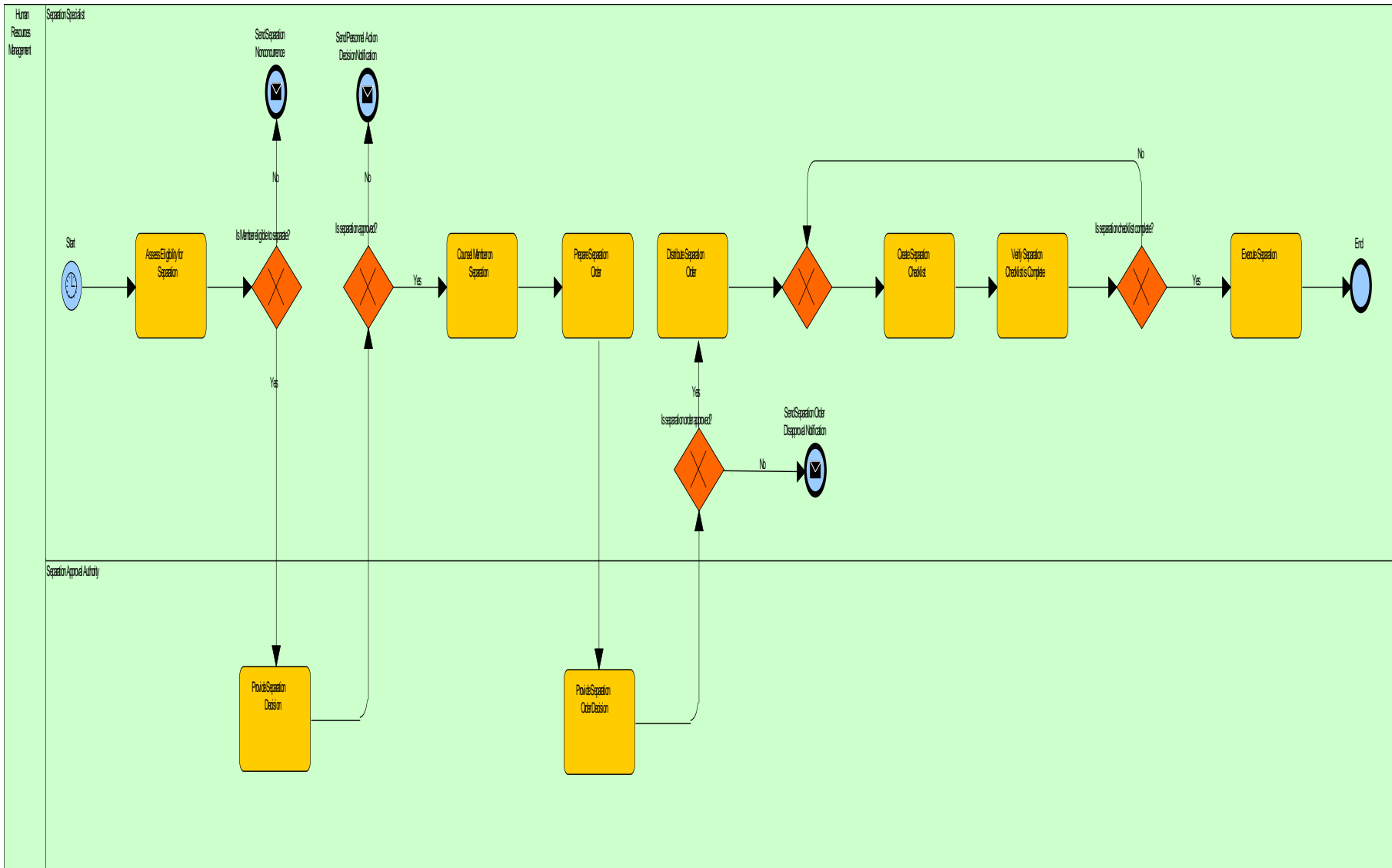

HL Manage Officer Involuntary
Retention (OV-6c Business Process)
System Architect
Thursday, January 10, 2013 10:25 AM

Comment

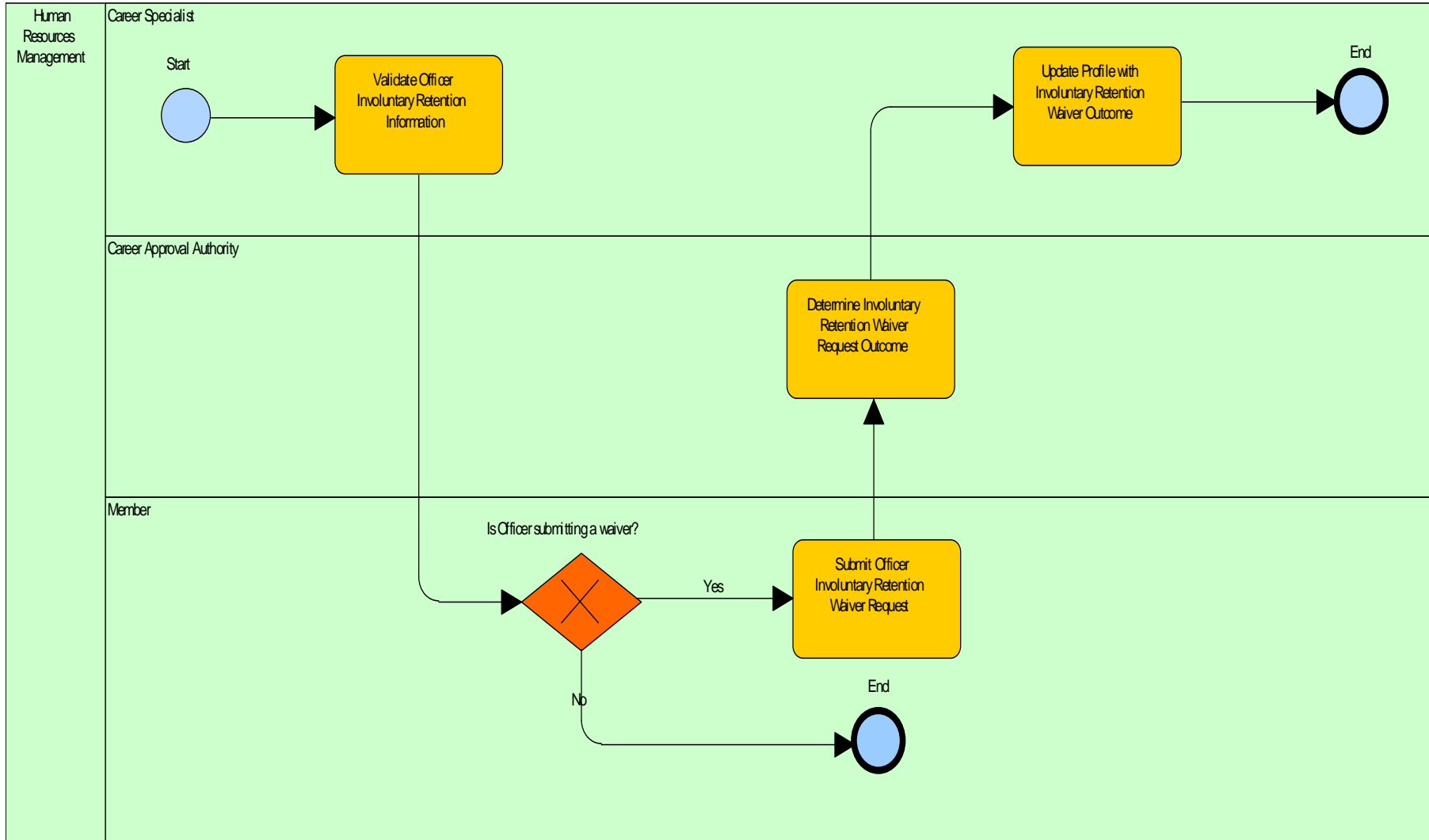

HL Manage Personnel Casualty (OV6c Business Process)

System Architect

Thursday, January 10, 2013 10:25 AM

Comment

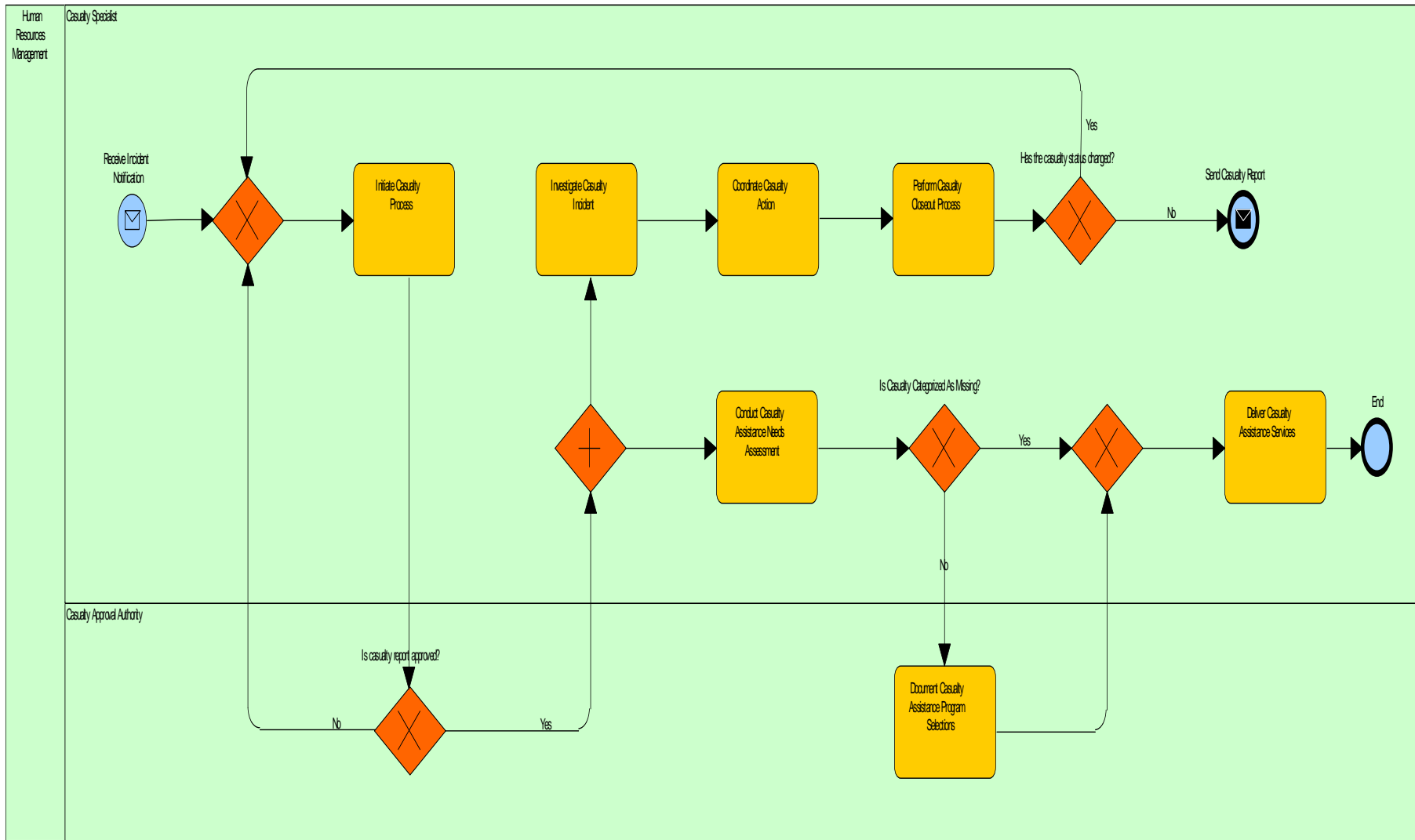

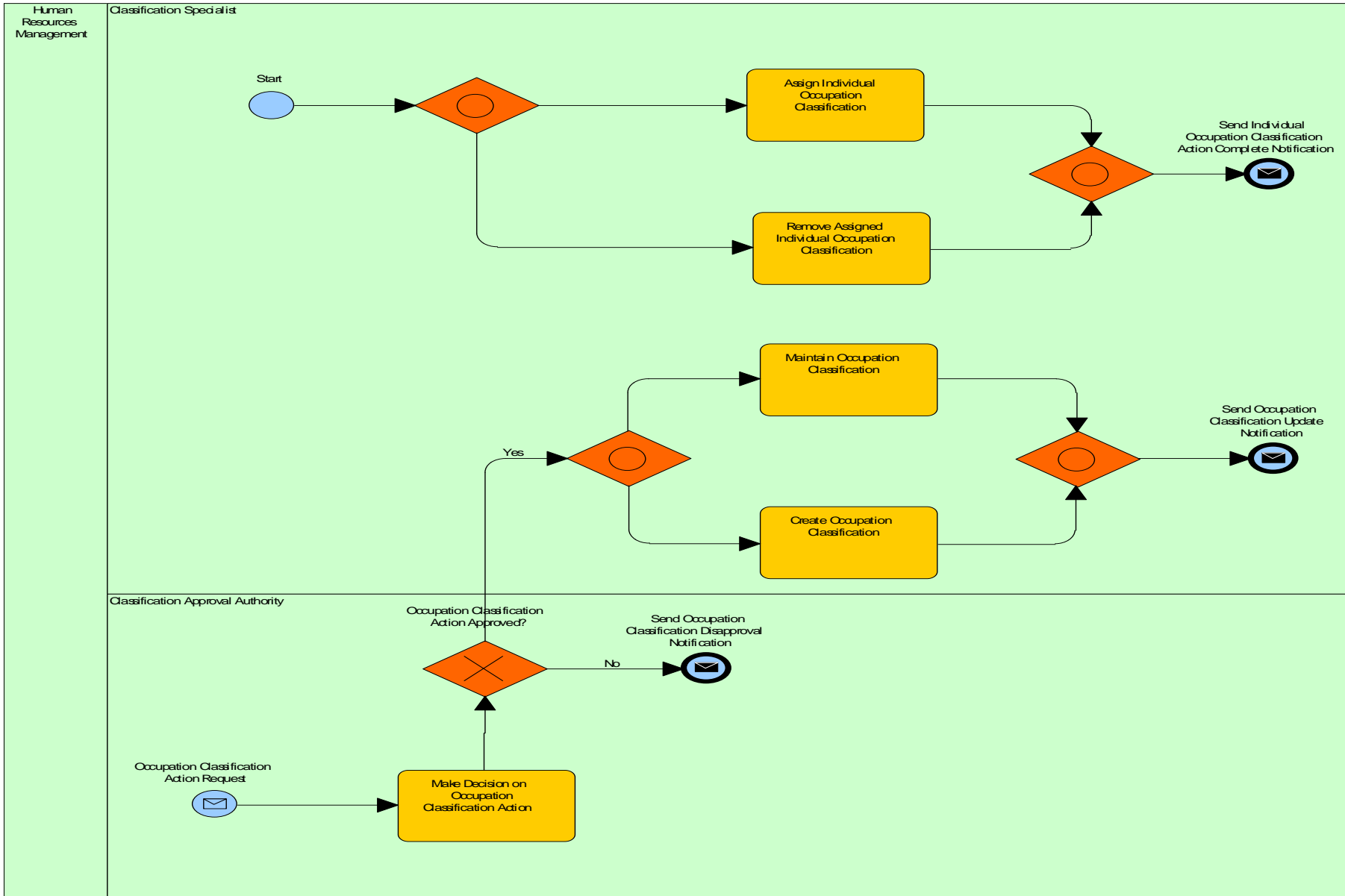

HL Manage Personnel Demotion (OV-6c Business Process)

System Architect

Friday, January 11, 2013 12:08 PM

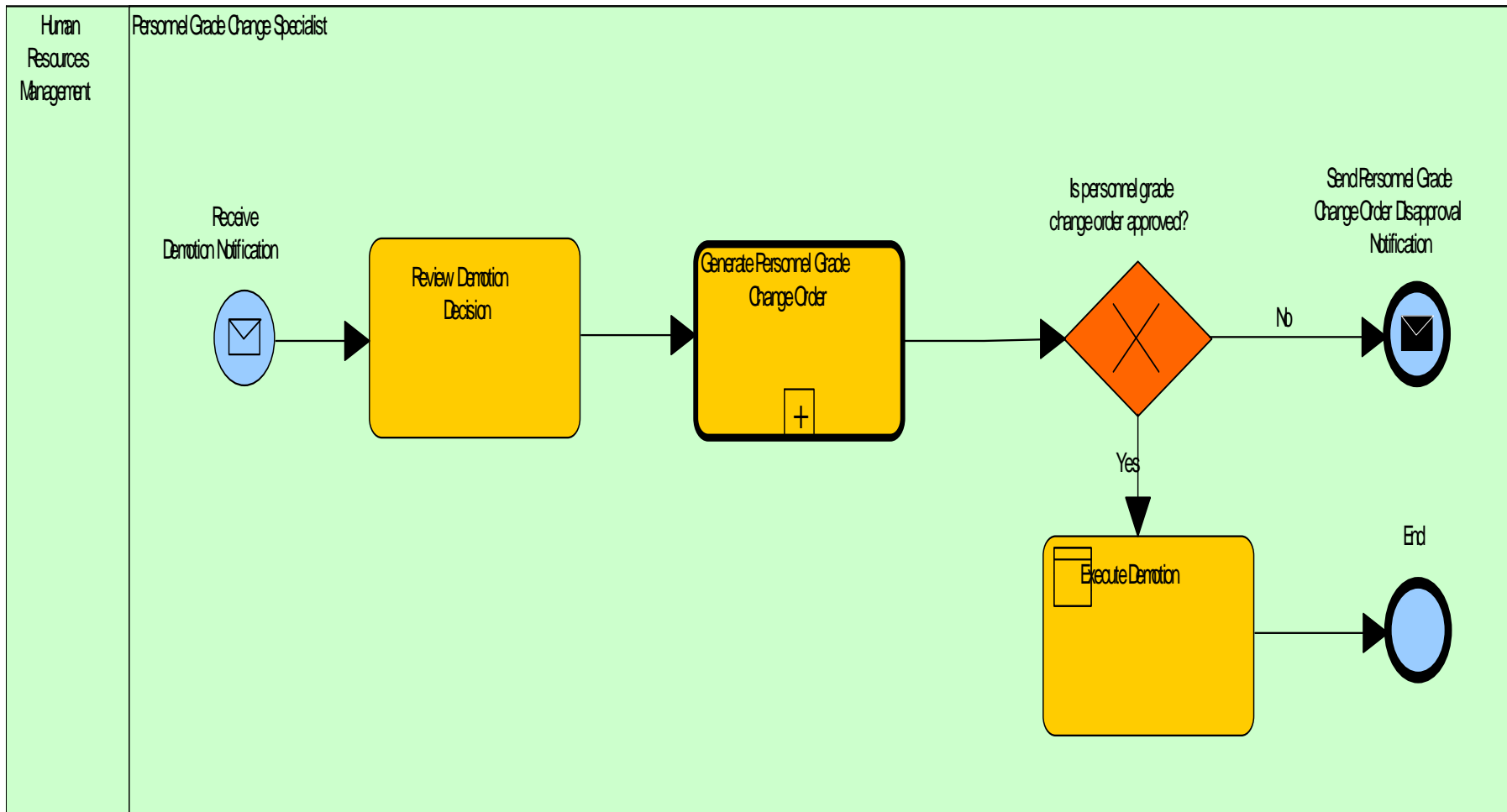

HL Manage Personnel Distribution
(OV-6c Business Process)

System Architect

Thursday, January 10, 2013 10:23 AM

Comment

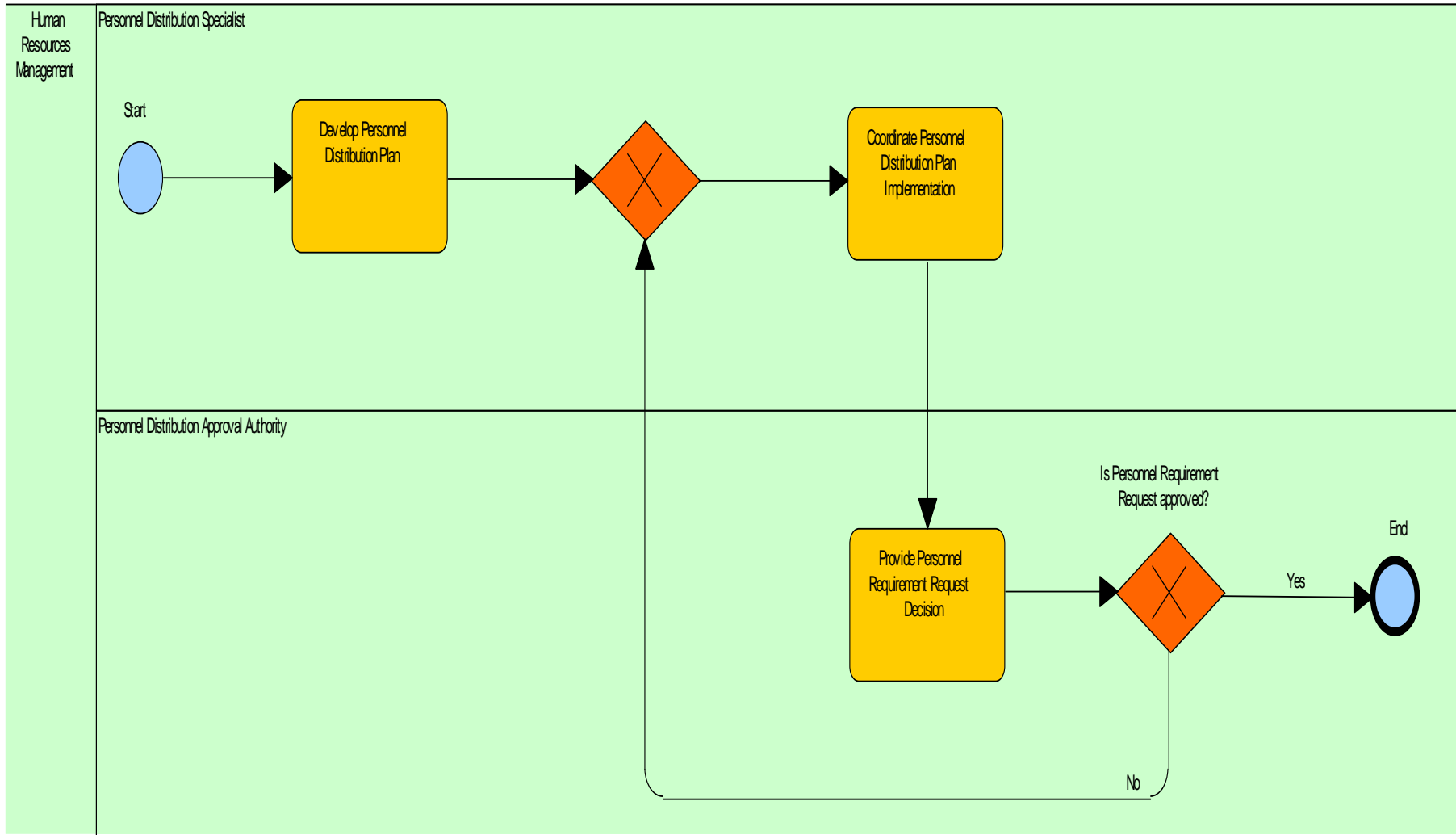

HL Manage Personnel Planning (OV/6c Business Process)

System Architect

Thursday, January 10, 2013 10:22 AM

Comment

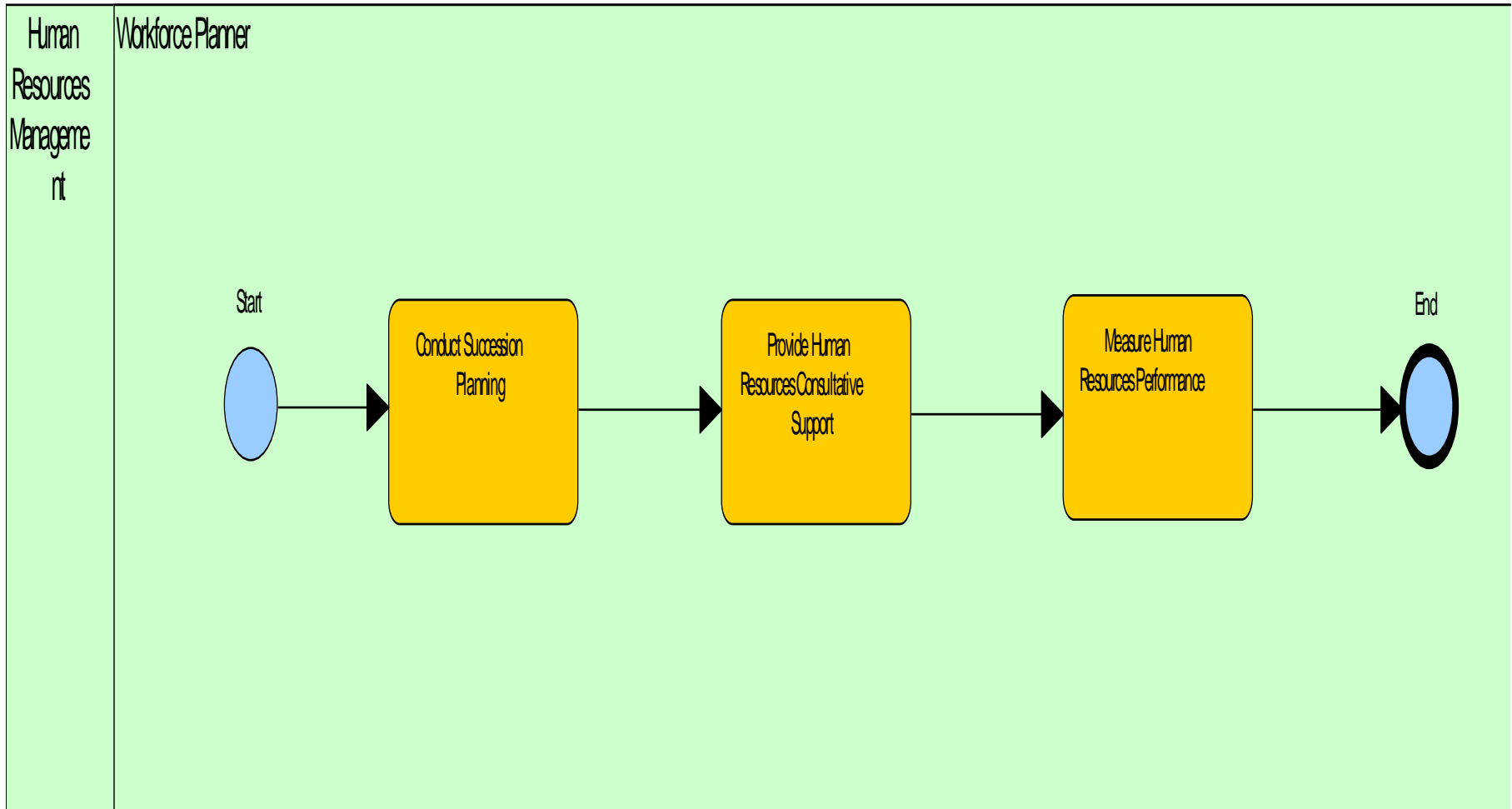

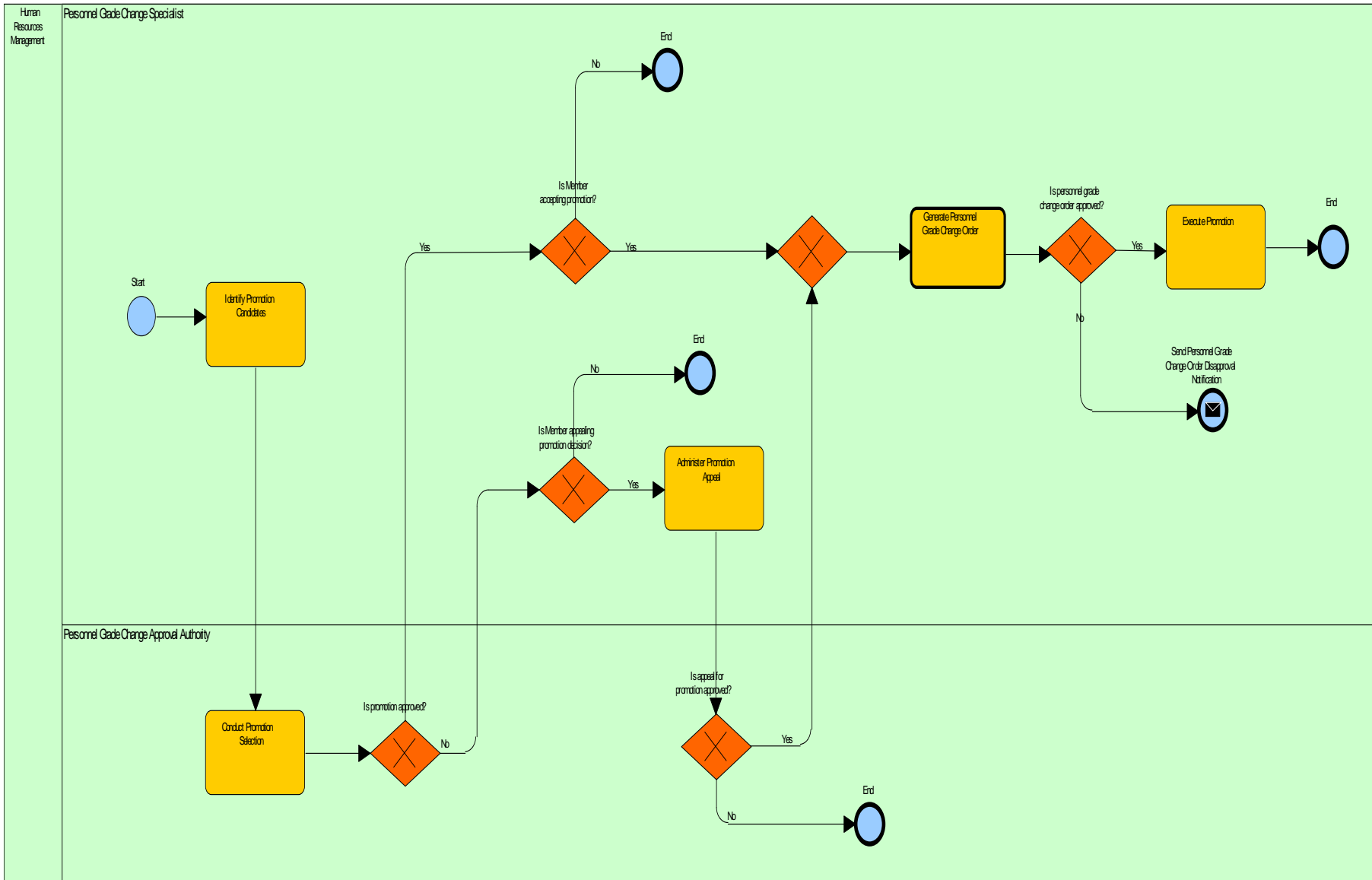

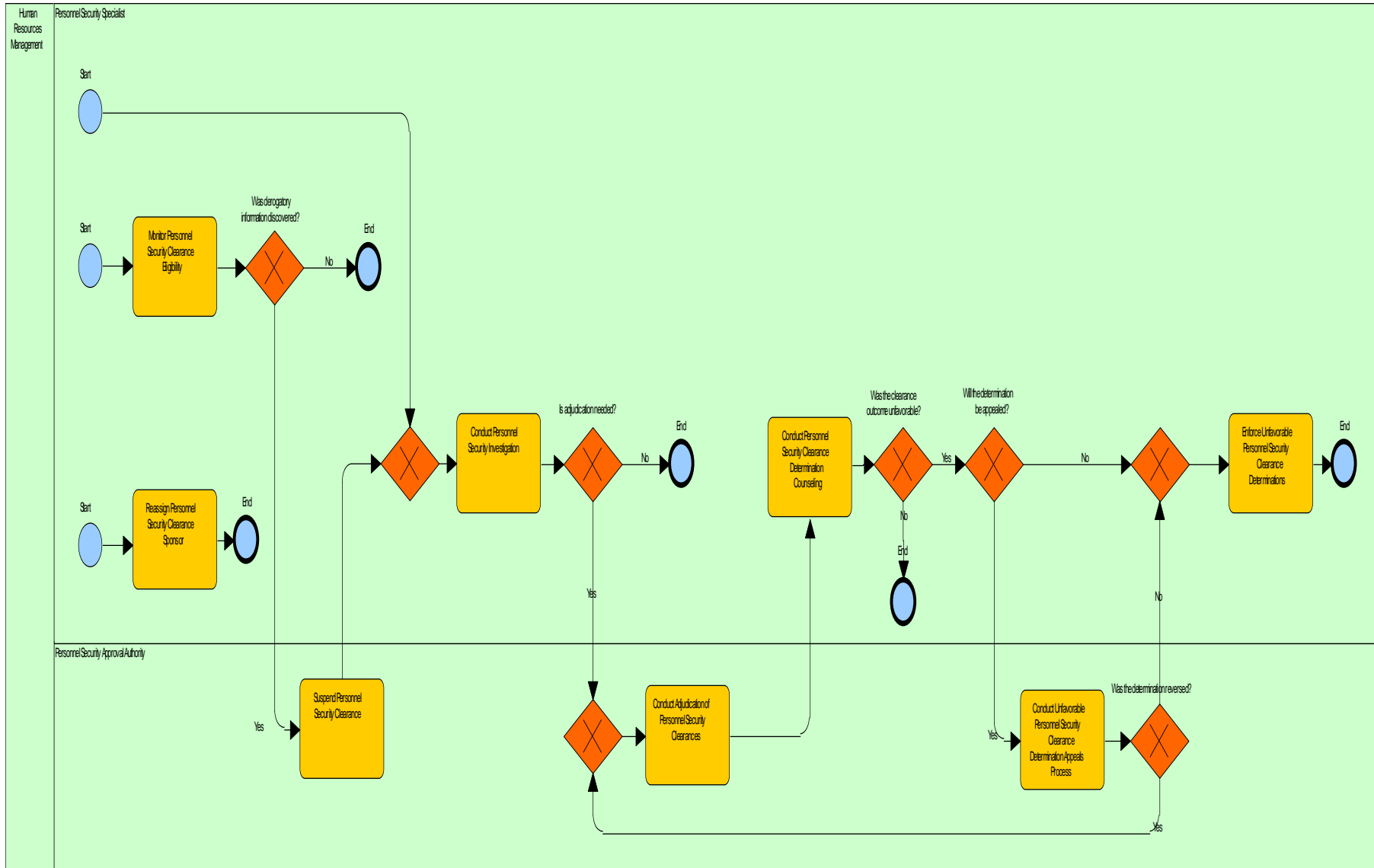

H. Manage Physical Evaluation Process
(OV-6c Business Process)
System Architect
Thursday, January 10, 2013 10:20 AM

Comment

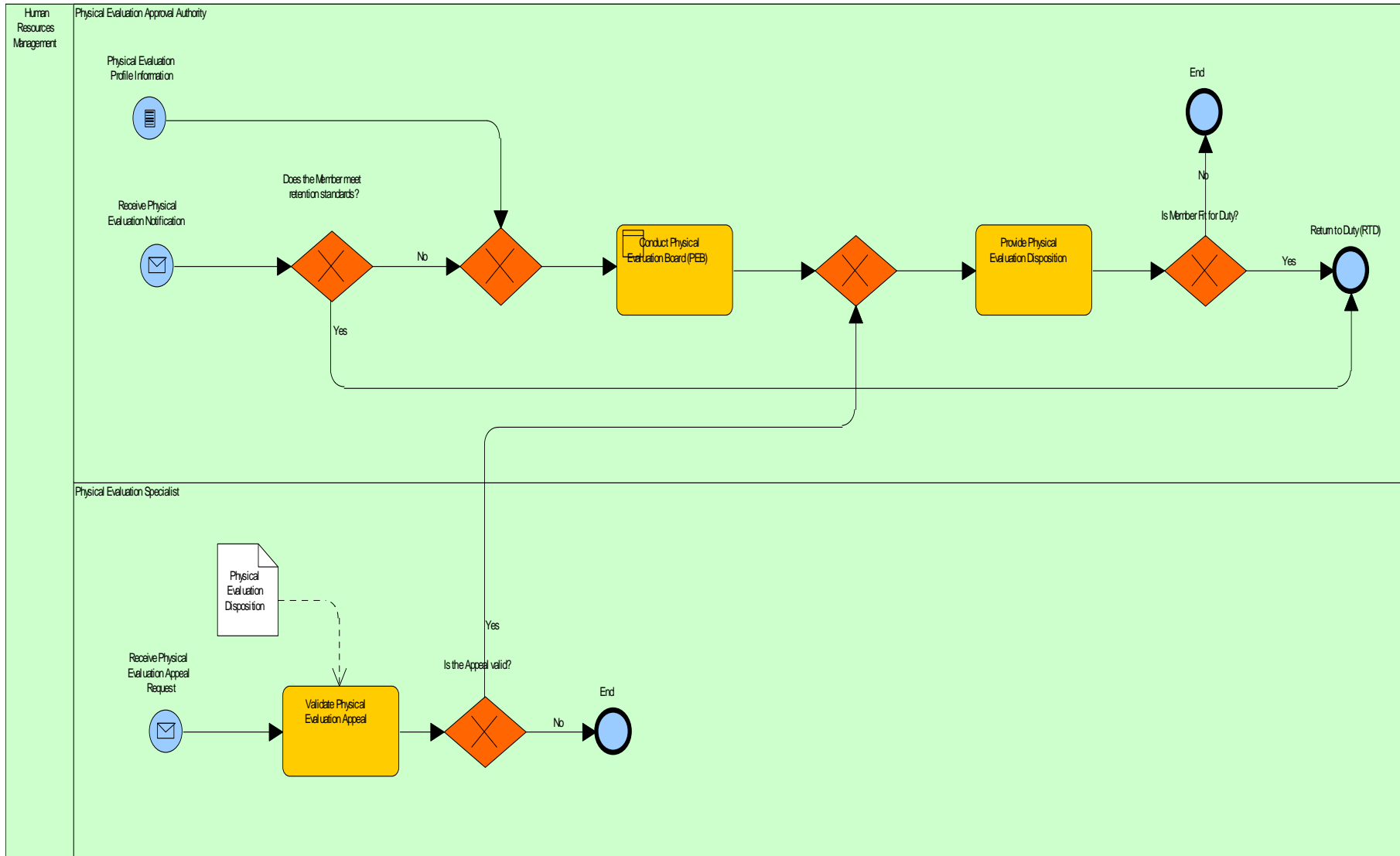

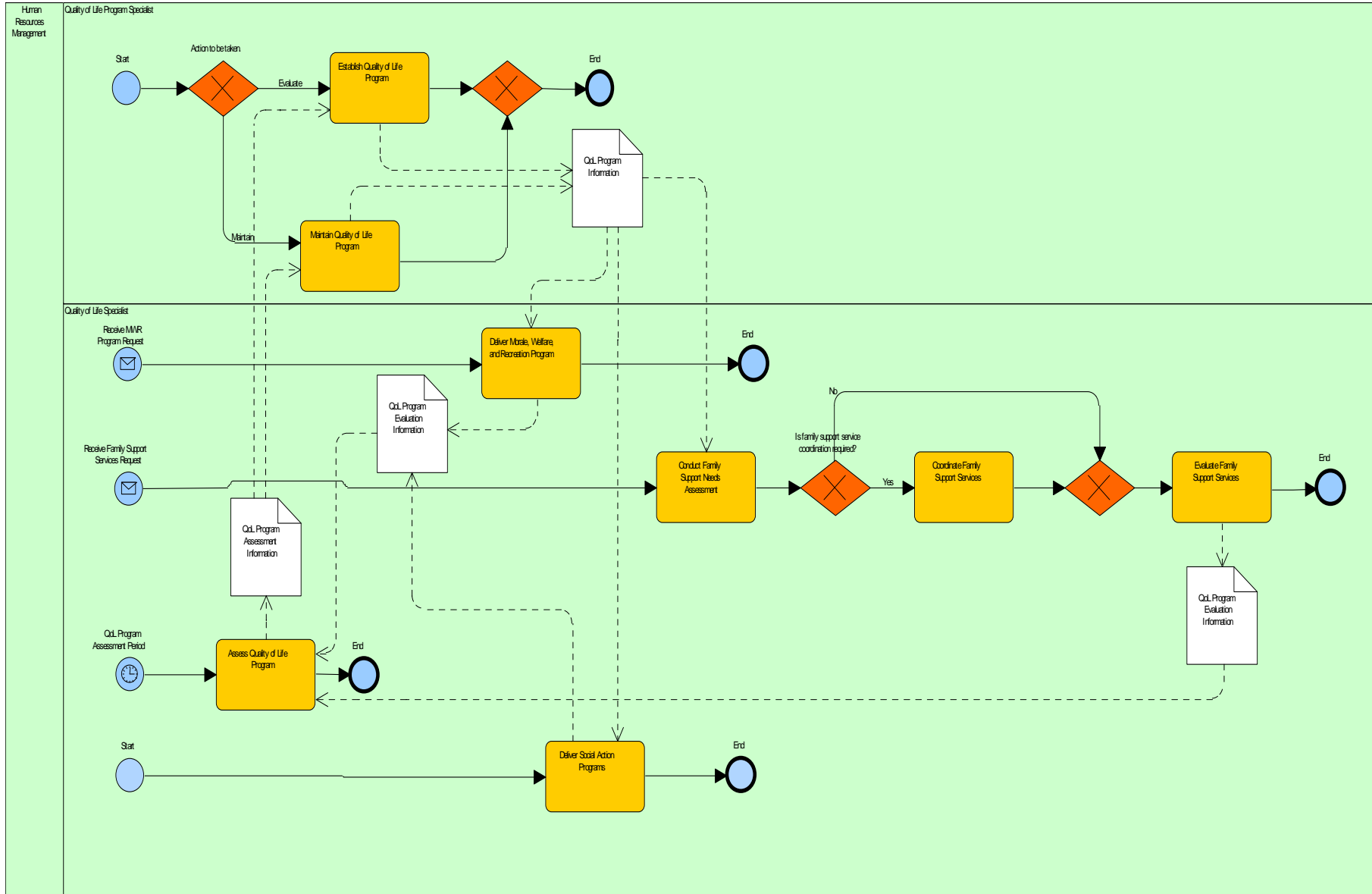

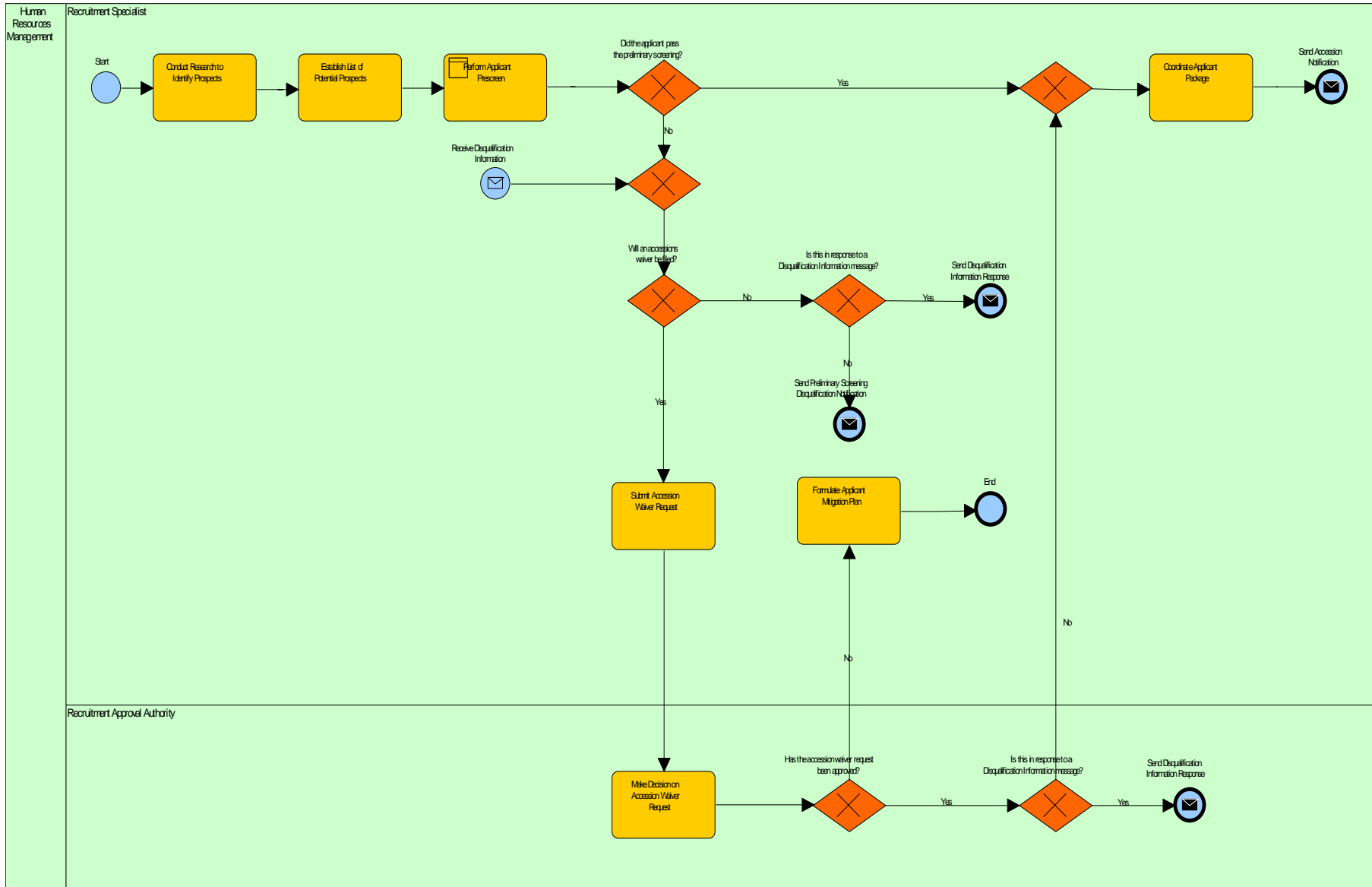

HL Manage Reimbursements
(CV-6c Business Process)
System Architect
Thursday, January 10, 2013

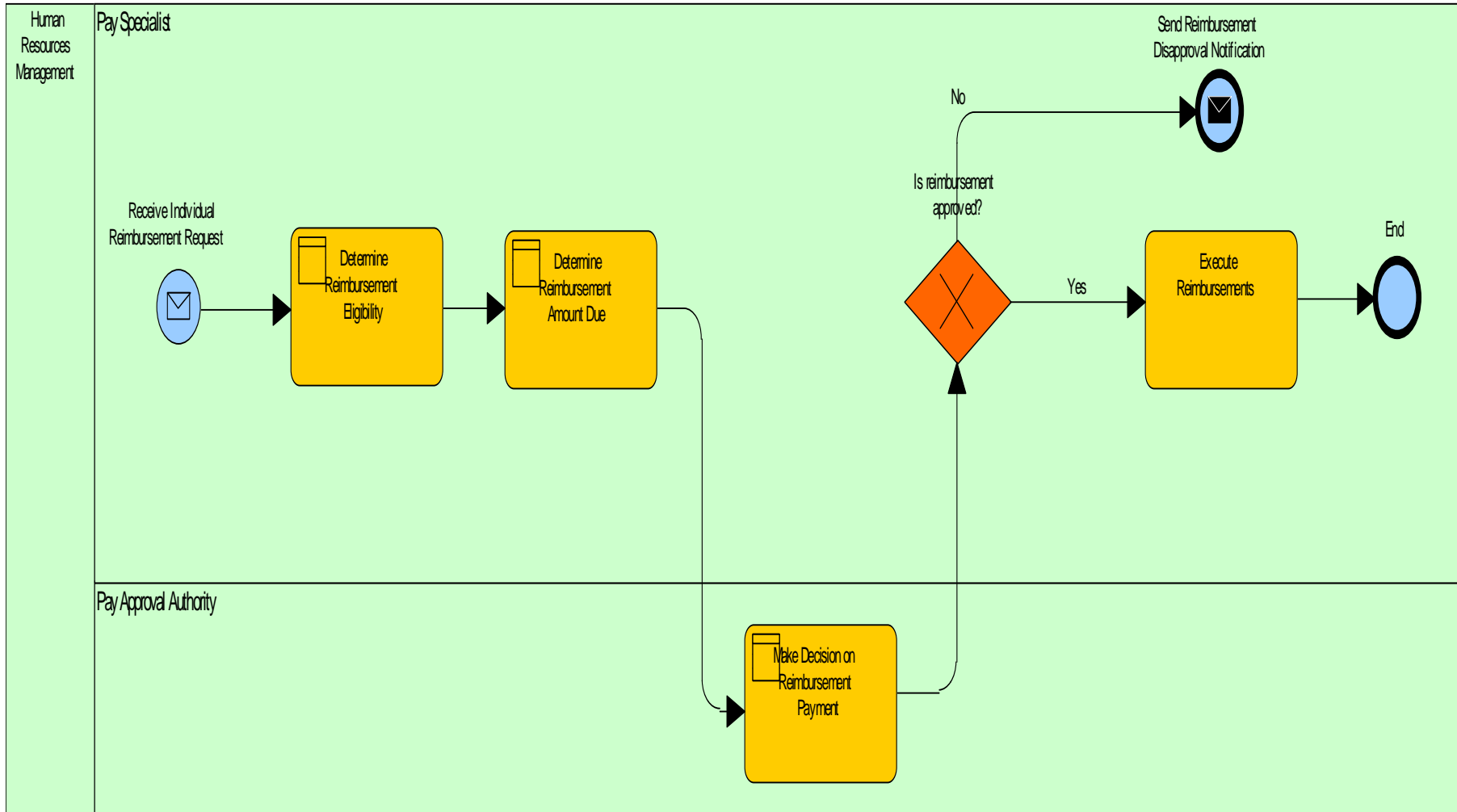

HL Manage Special Category
Retention (OV-6c Business
Process)
System Architect

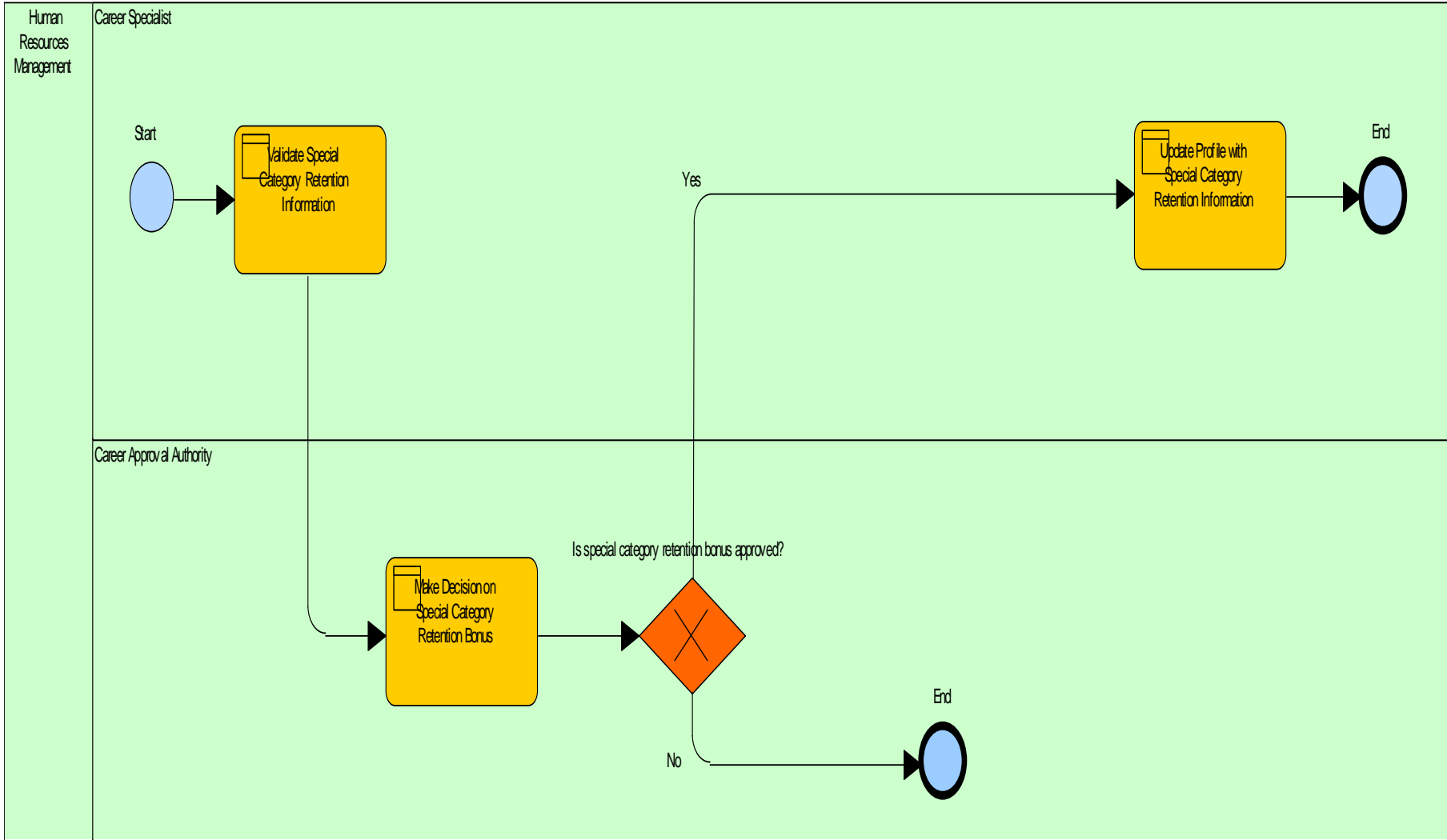

H.L Manage Transition Assistance
(CV-6c Business Process)
System Architect
Thursday, January 10, 2013 10:17

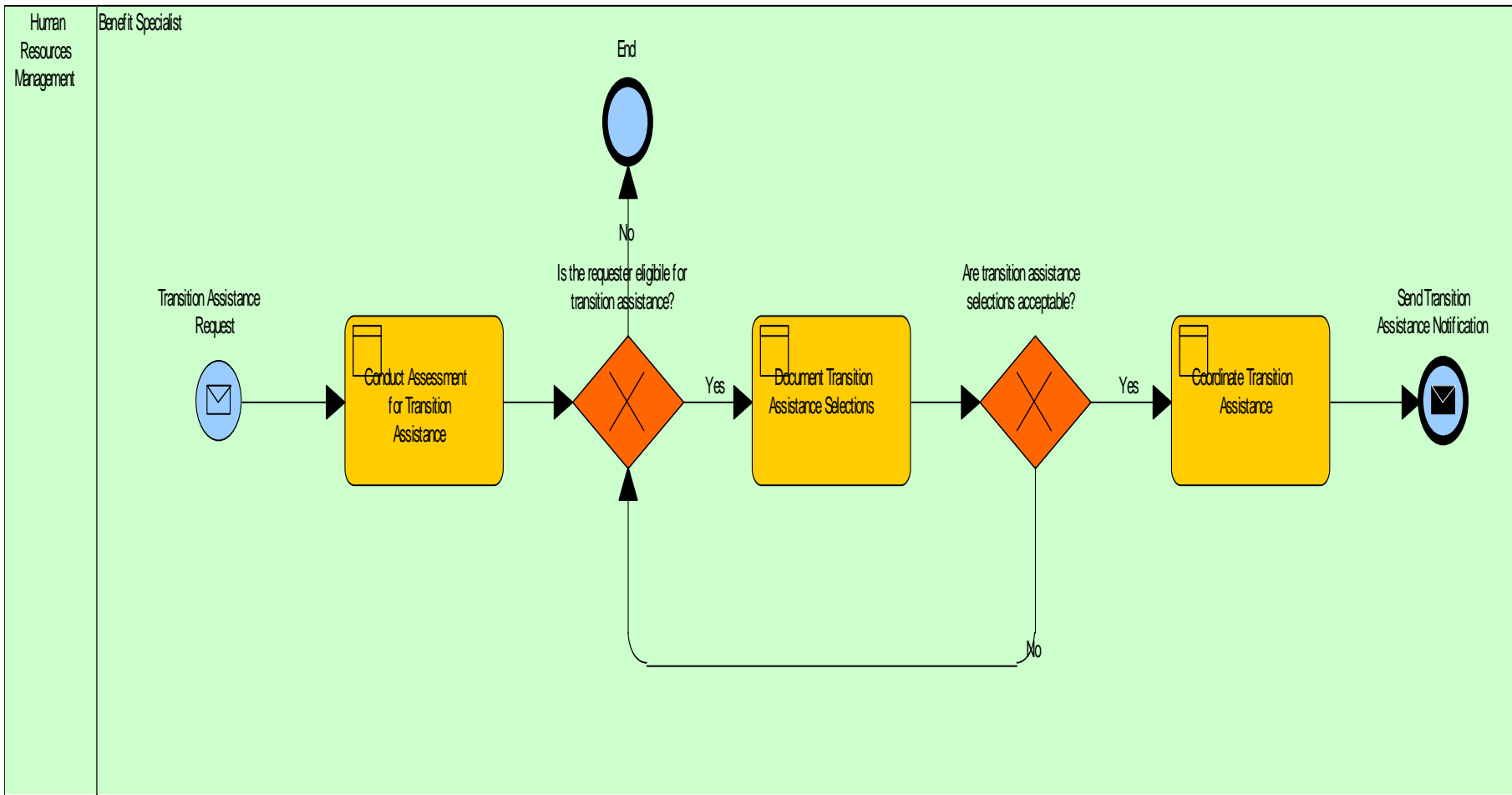

HL Manpower - Administer OUID (OV-

6c Business Process)

System Architect

Thursday, January 10, 2013 10:16 AM

Comment

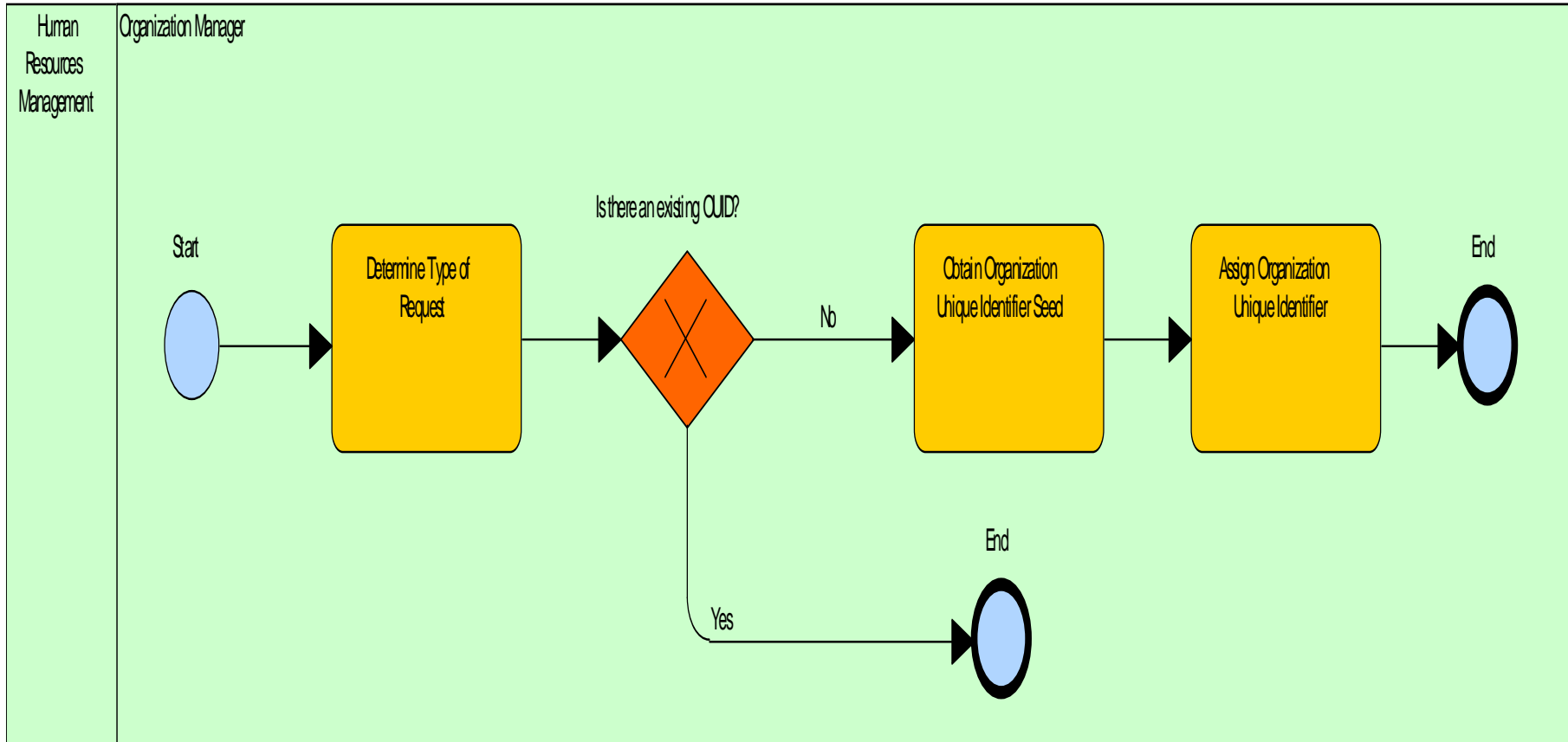

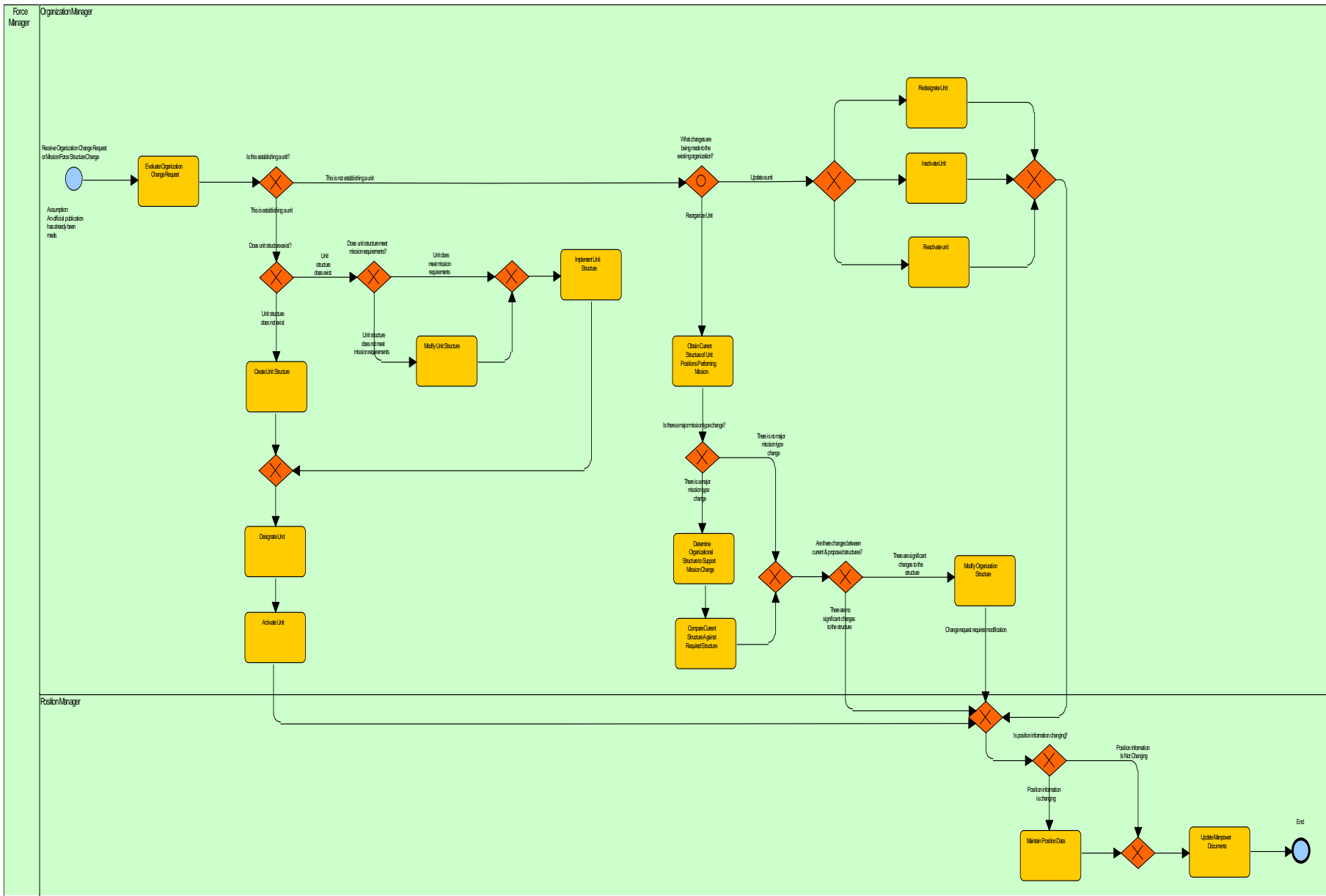

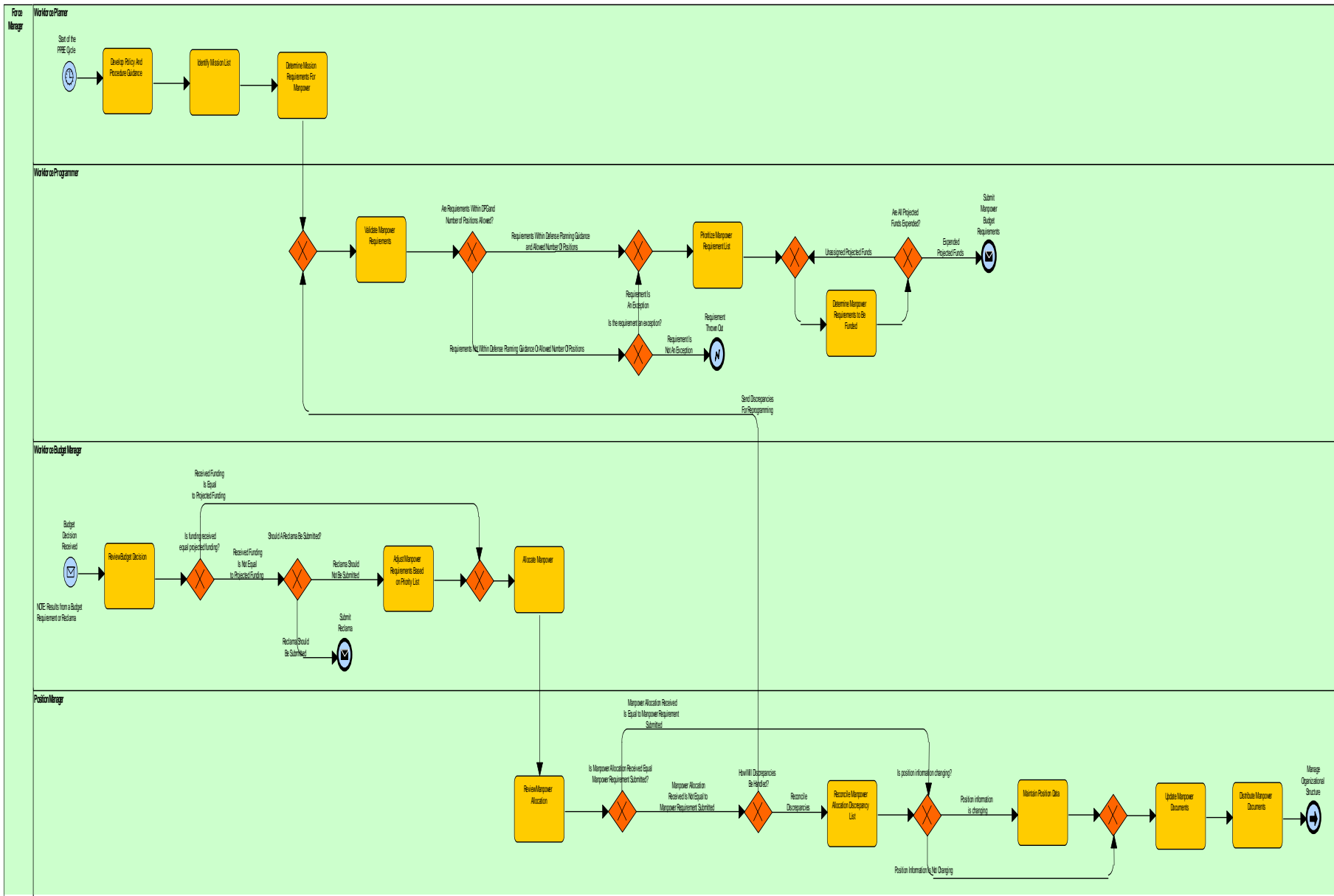

HL Manpower - Process Manpower Change (OV4c
Business Process)
System Architect
Thursday, January 10, 2013 10:15 AM

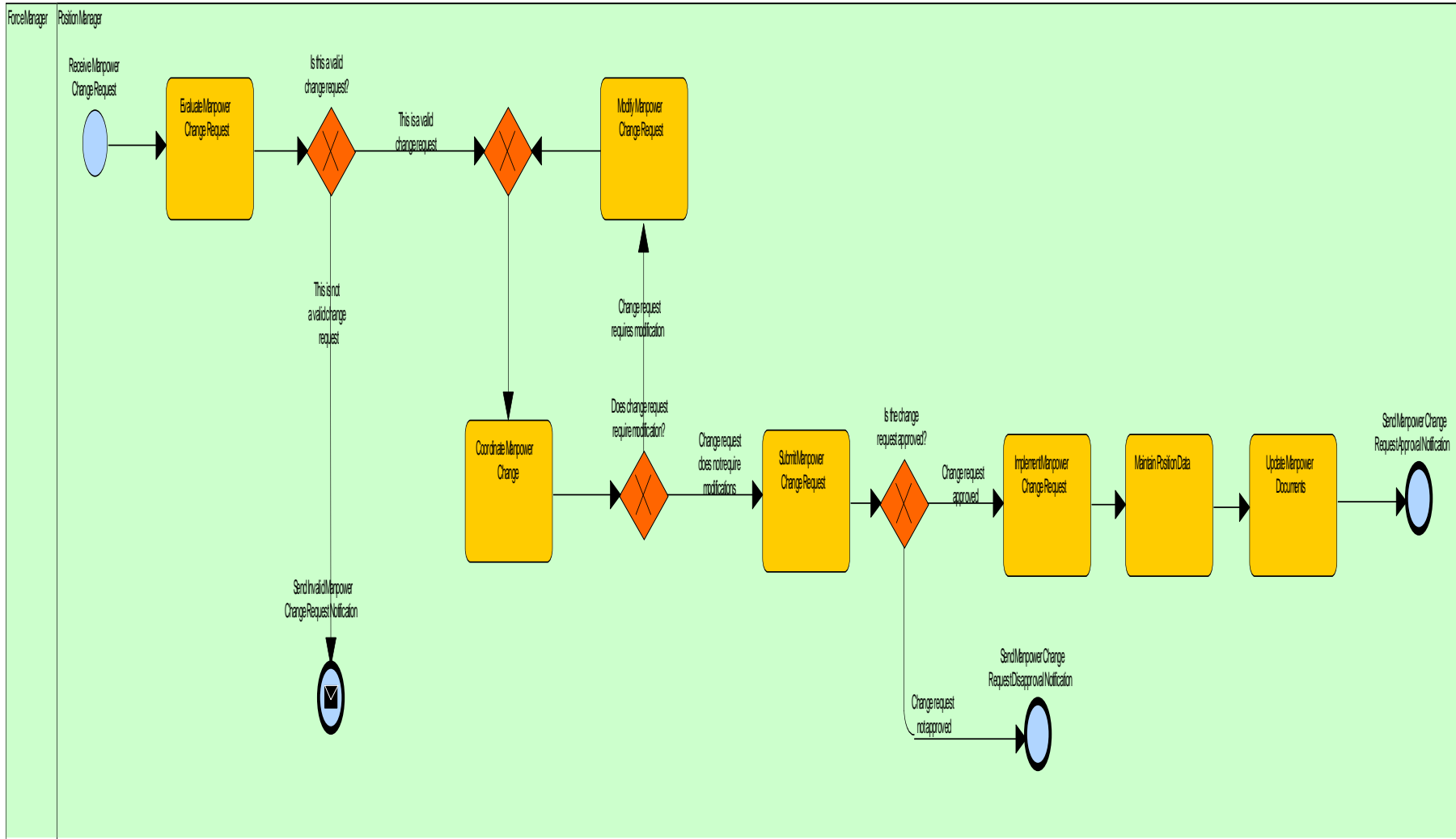

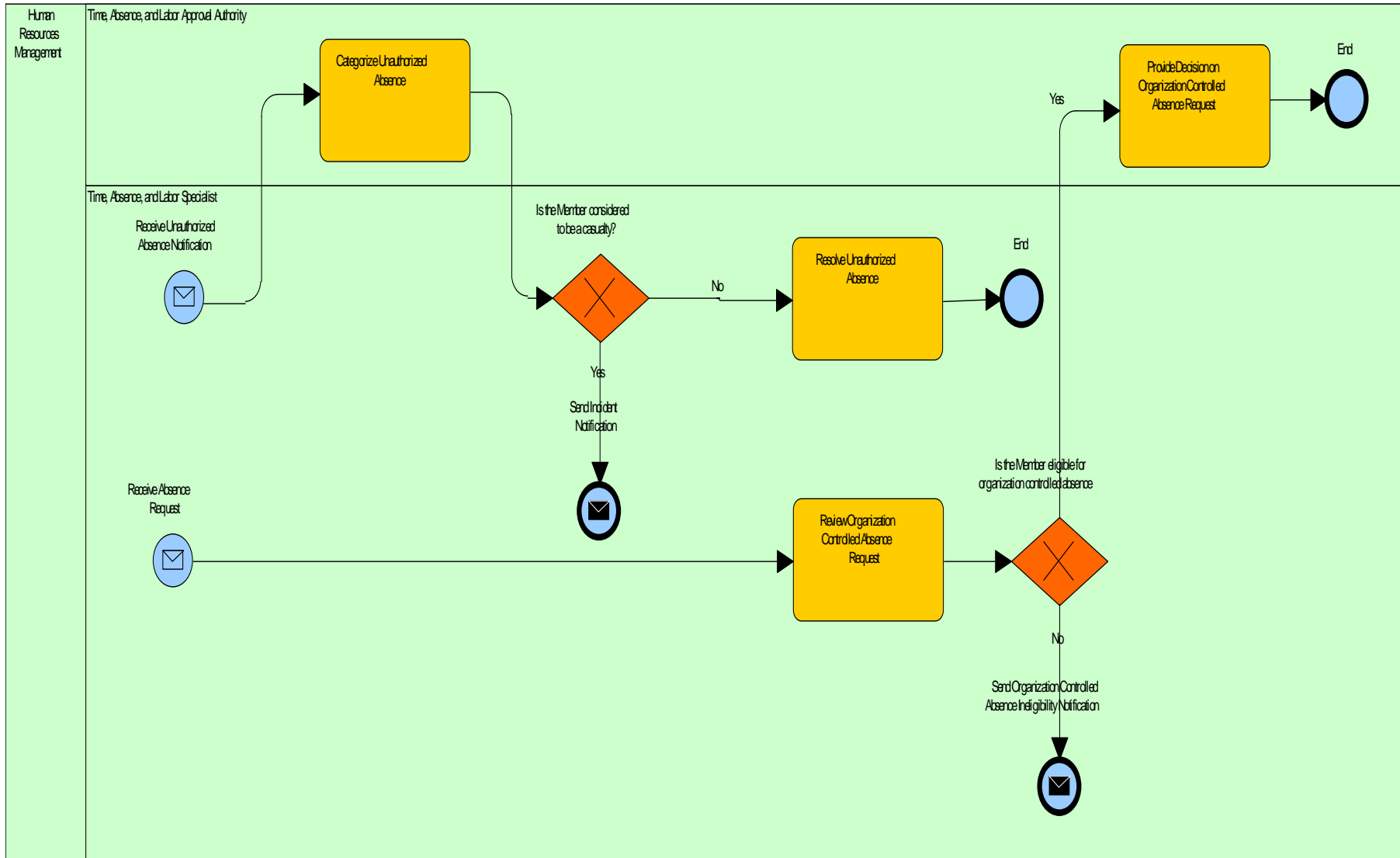

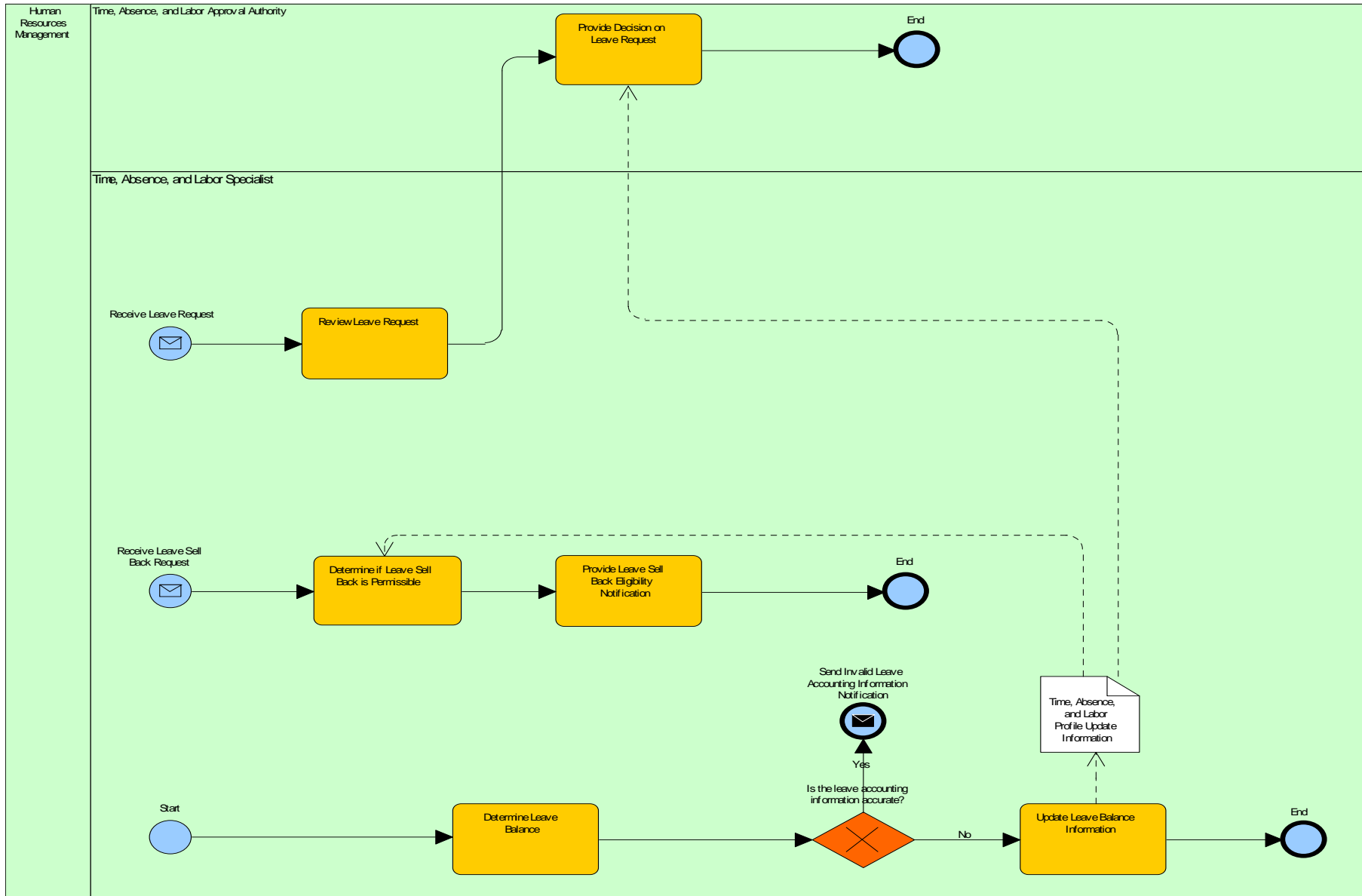

HL Perform Personnel Readiness Assessment (OV-6c Business Process)
System Architect
Thursday, January 10, 2013 10:13 AM

Comment

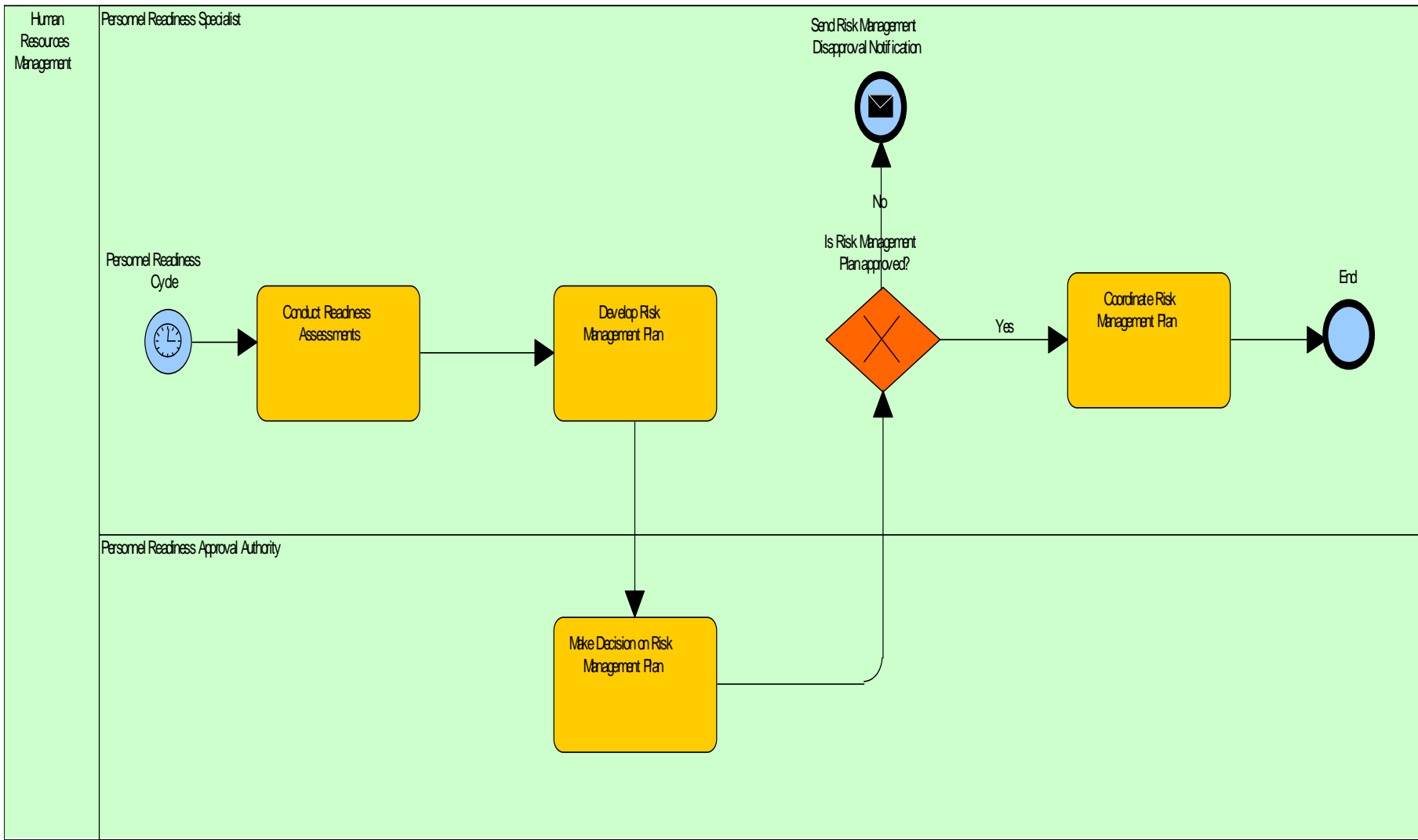

H. Perform Workforce Analysis (OV-6c
Business Process)

System Architect

Thursday, January 10, 2013 10:05 AM

Comment

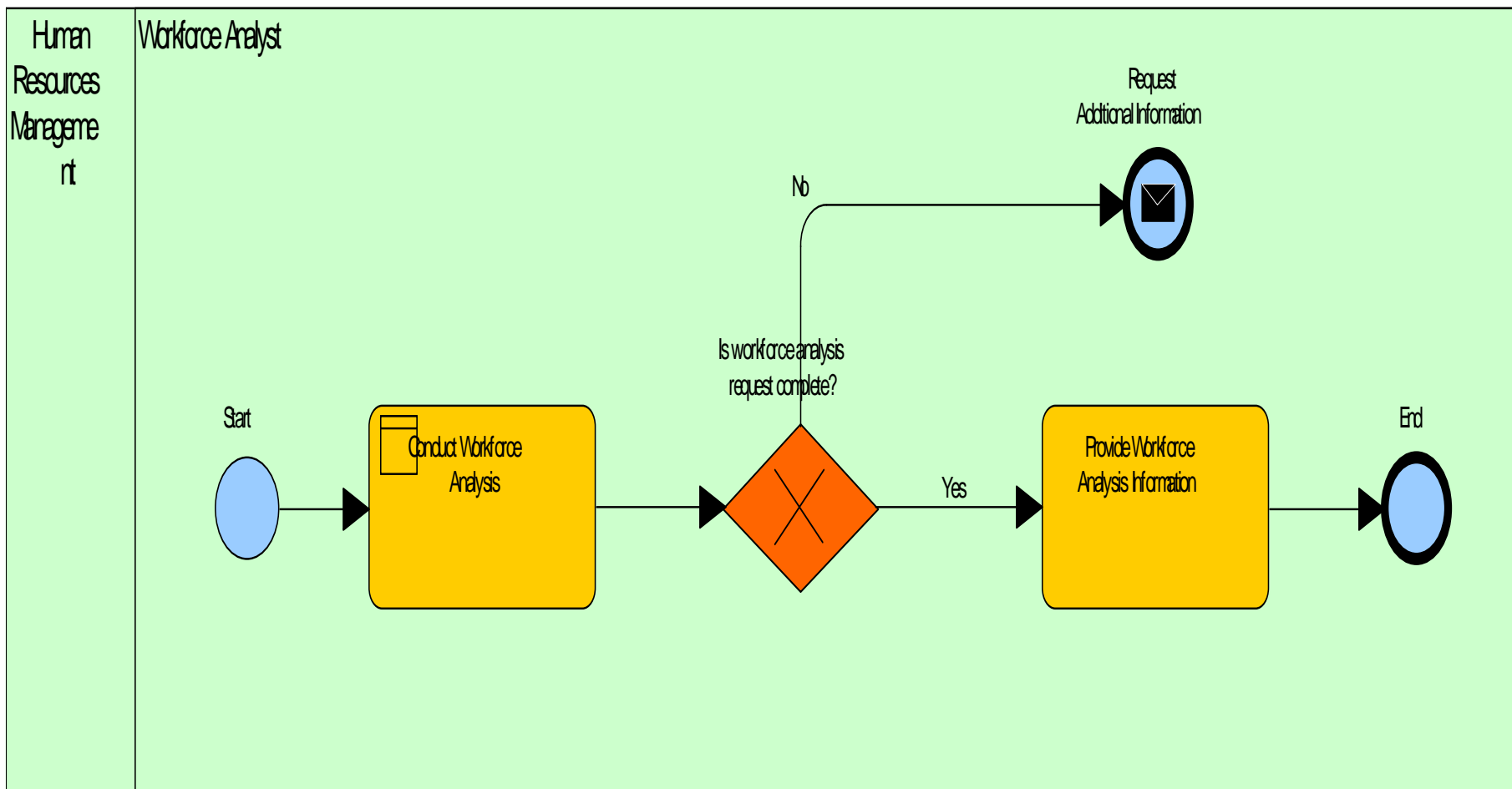

Implement Case in Foreign Military Sales Trust Fund
 (O&G Business Process)
 System Architect
 Tuesday, February 14, 2012 11:29 AM

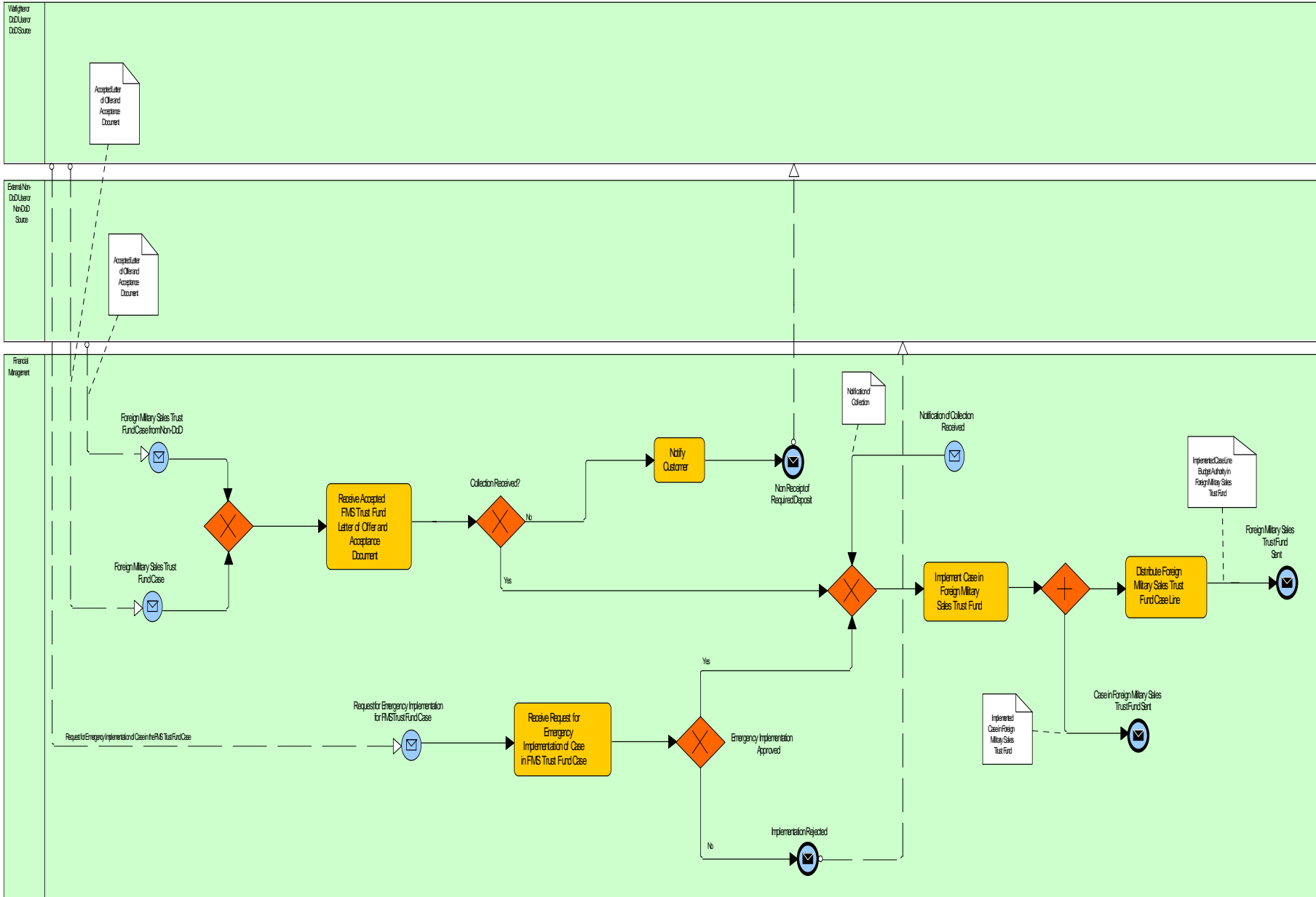

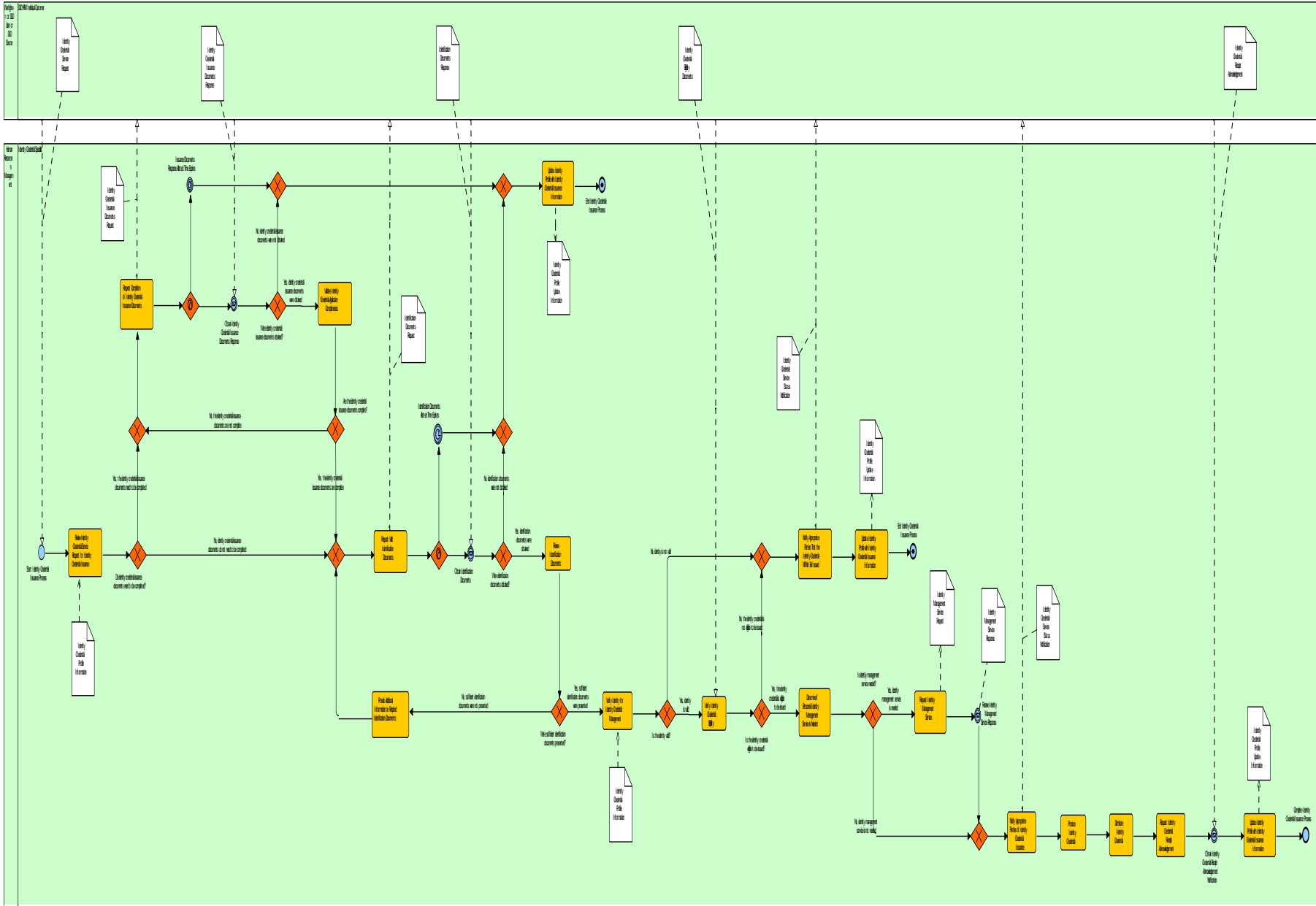

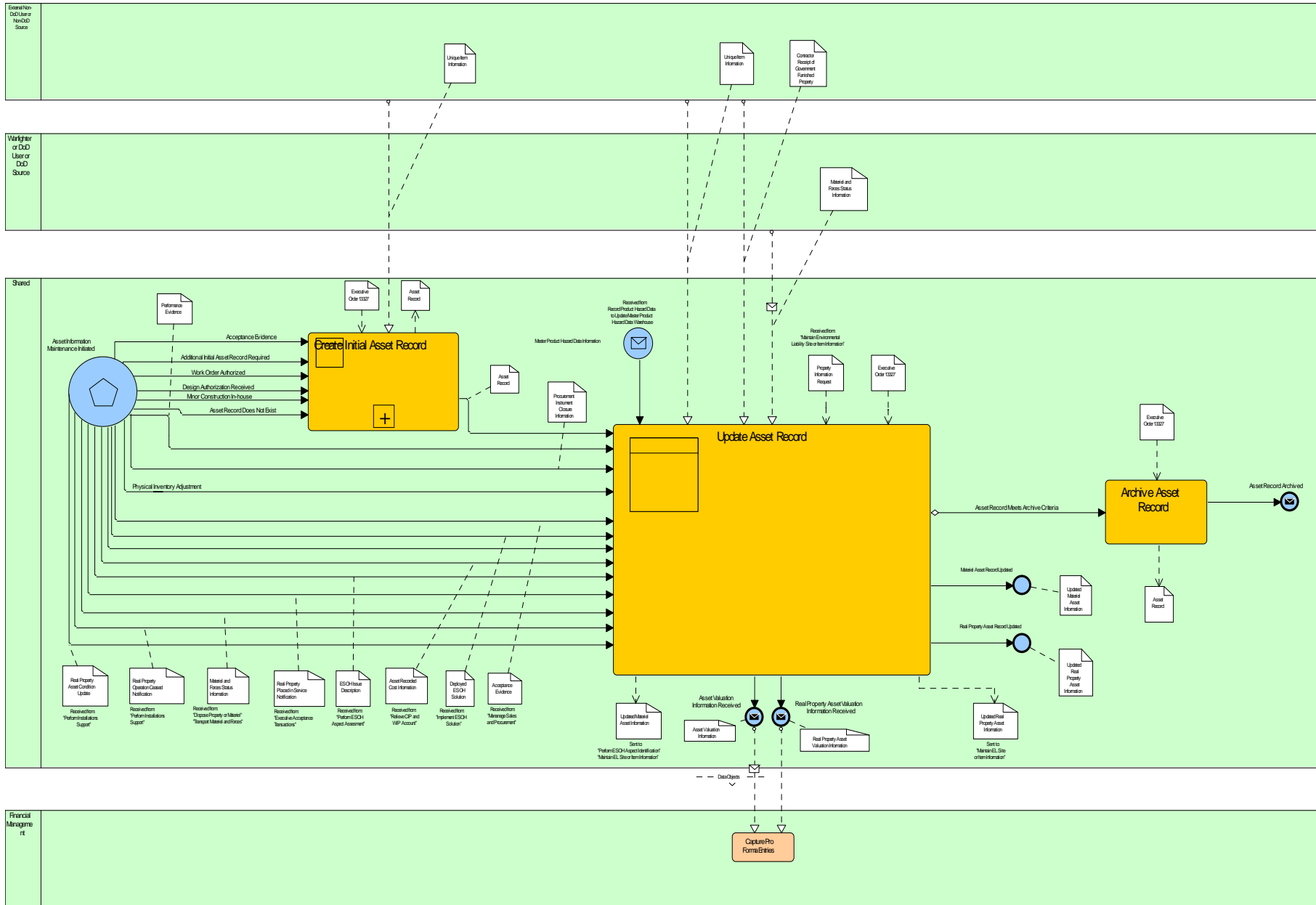

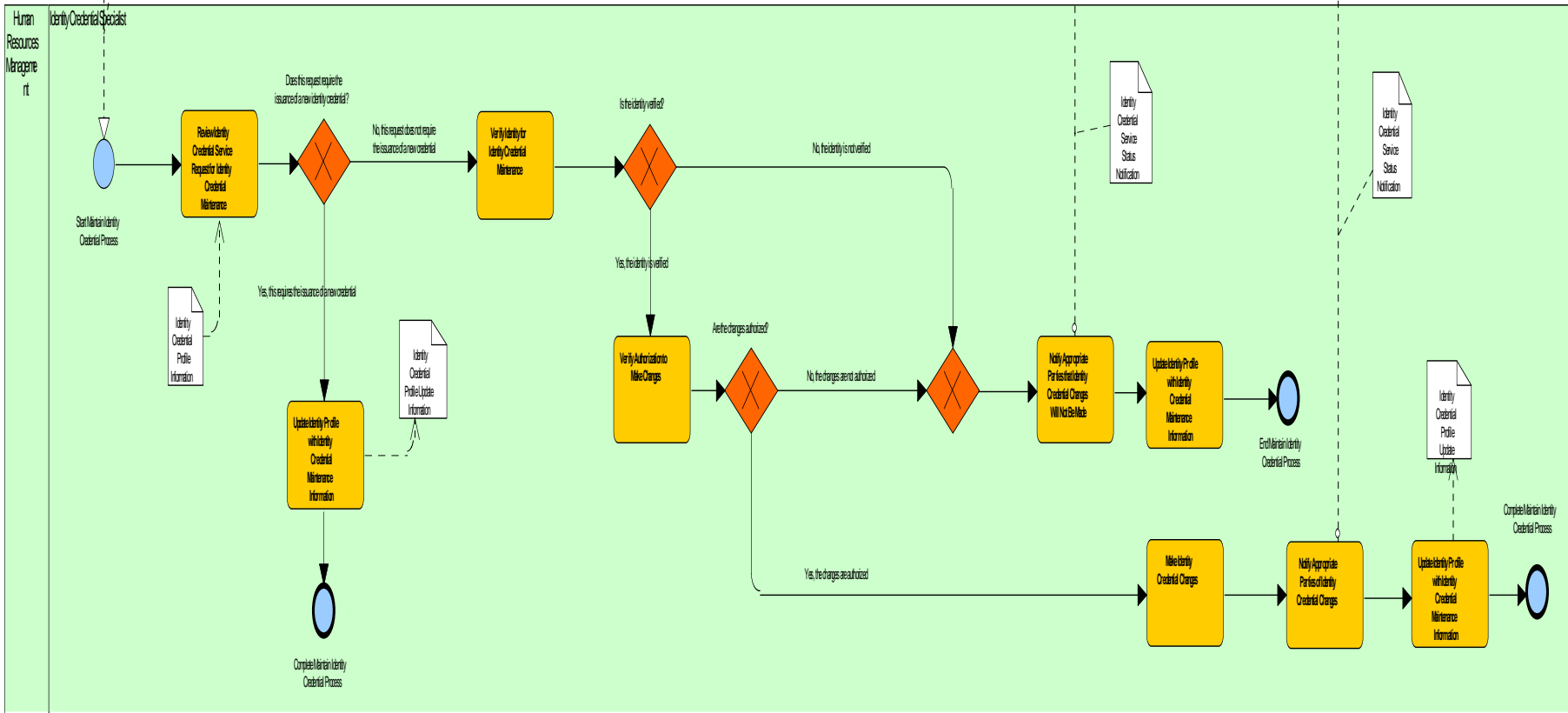
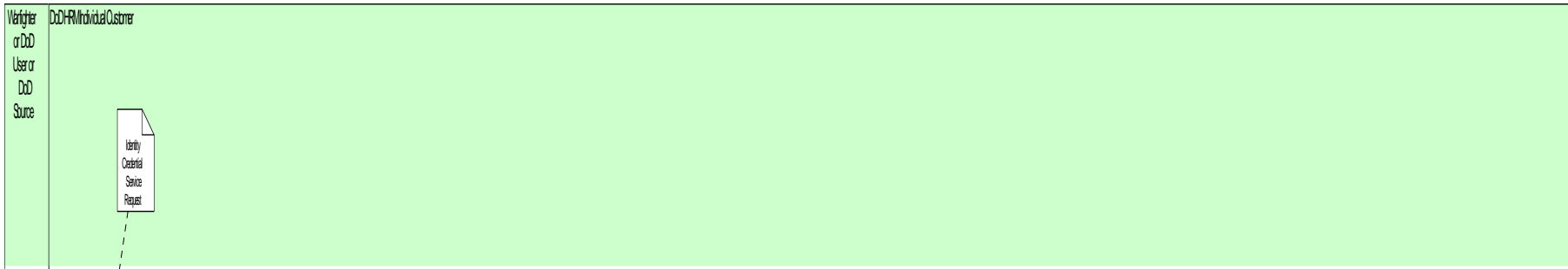

Financial Management

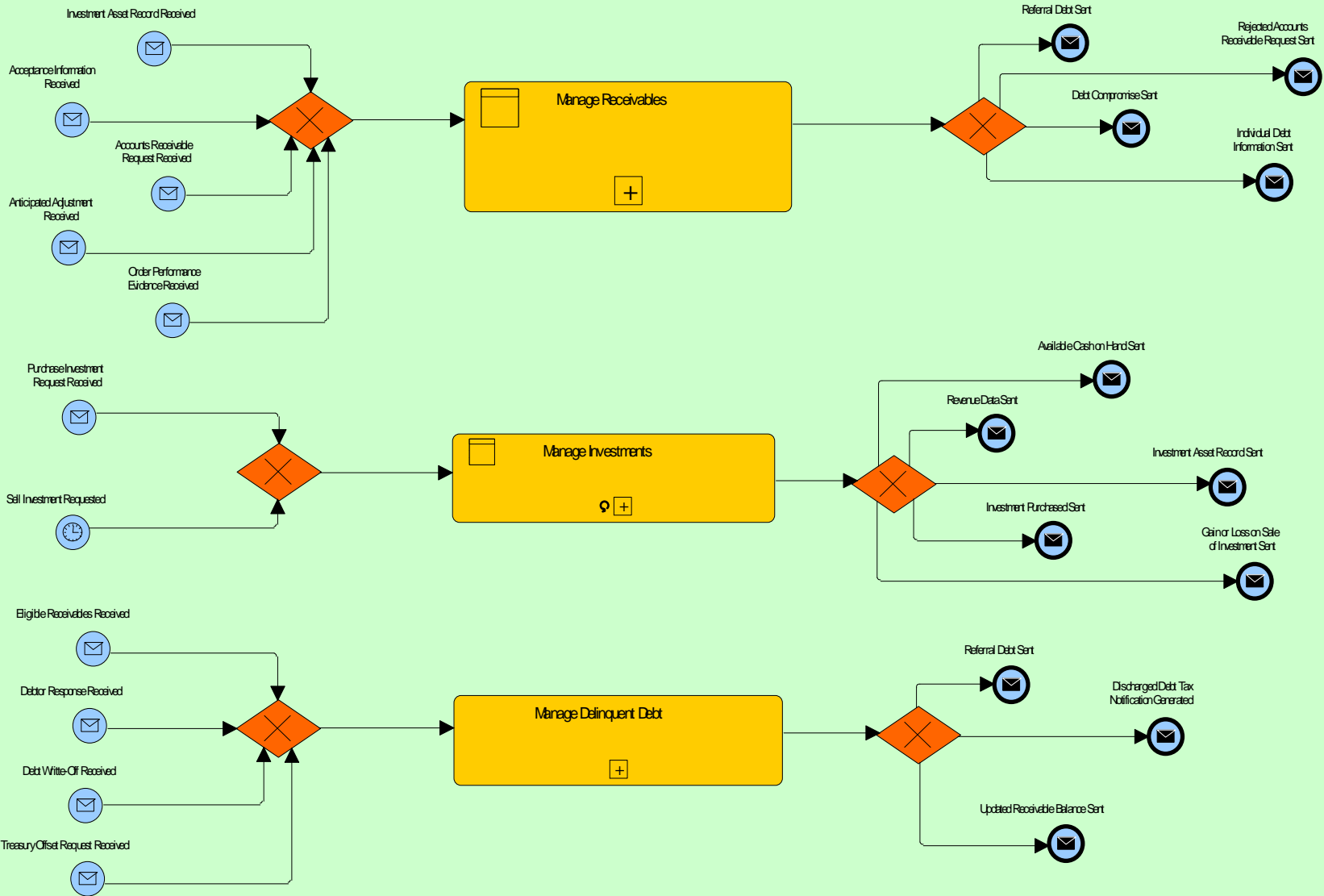

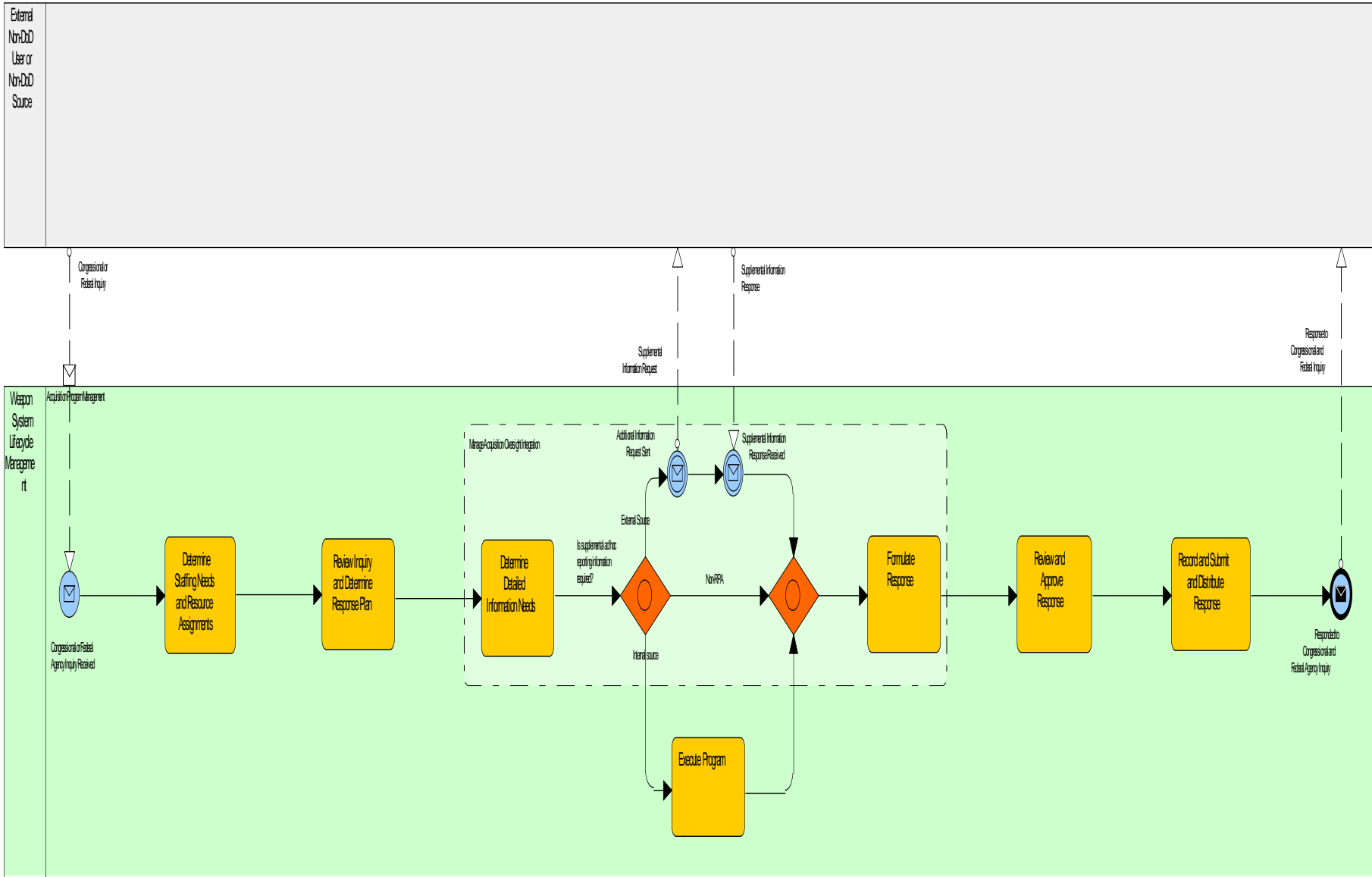

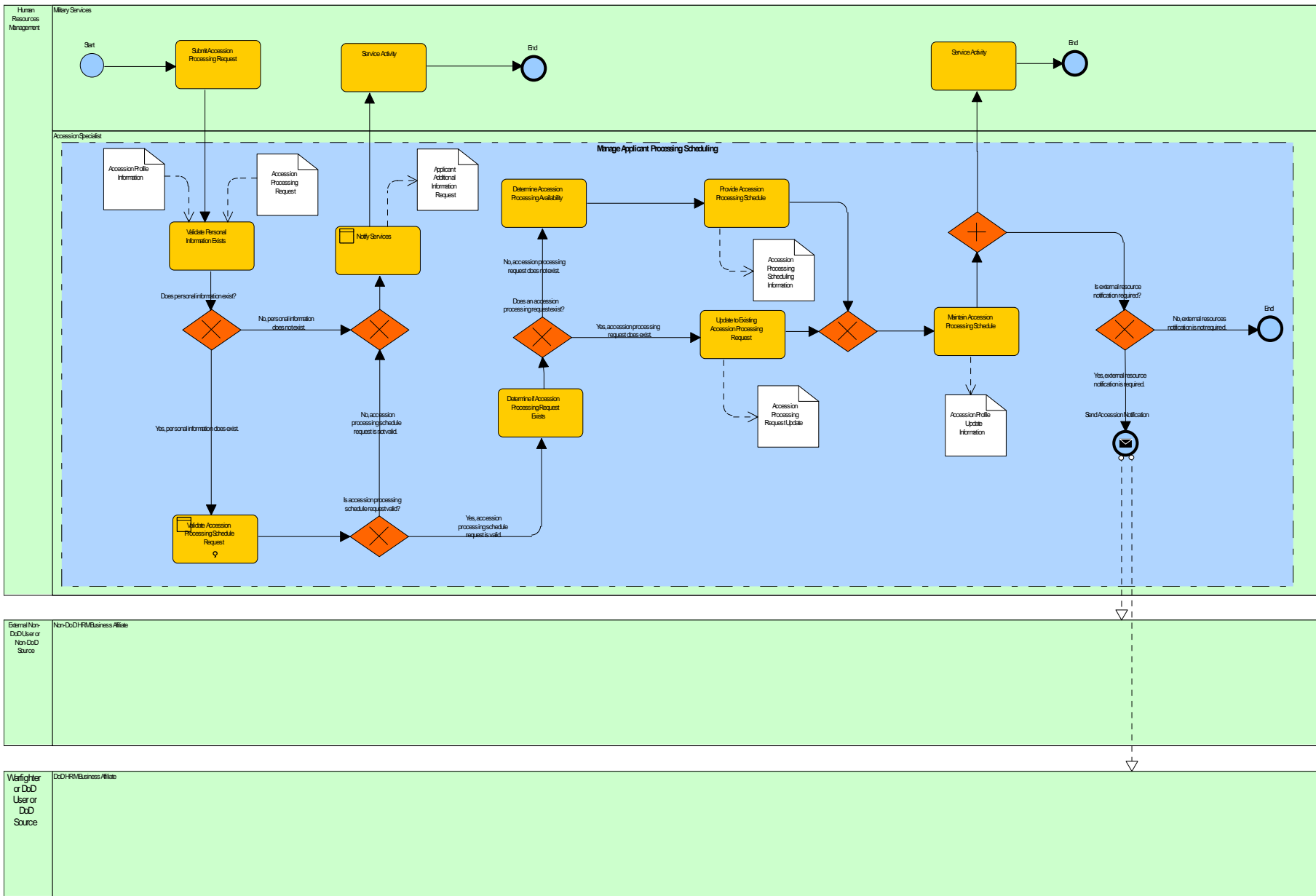

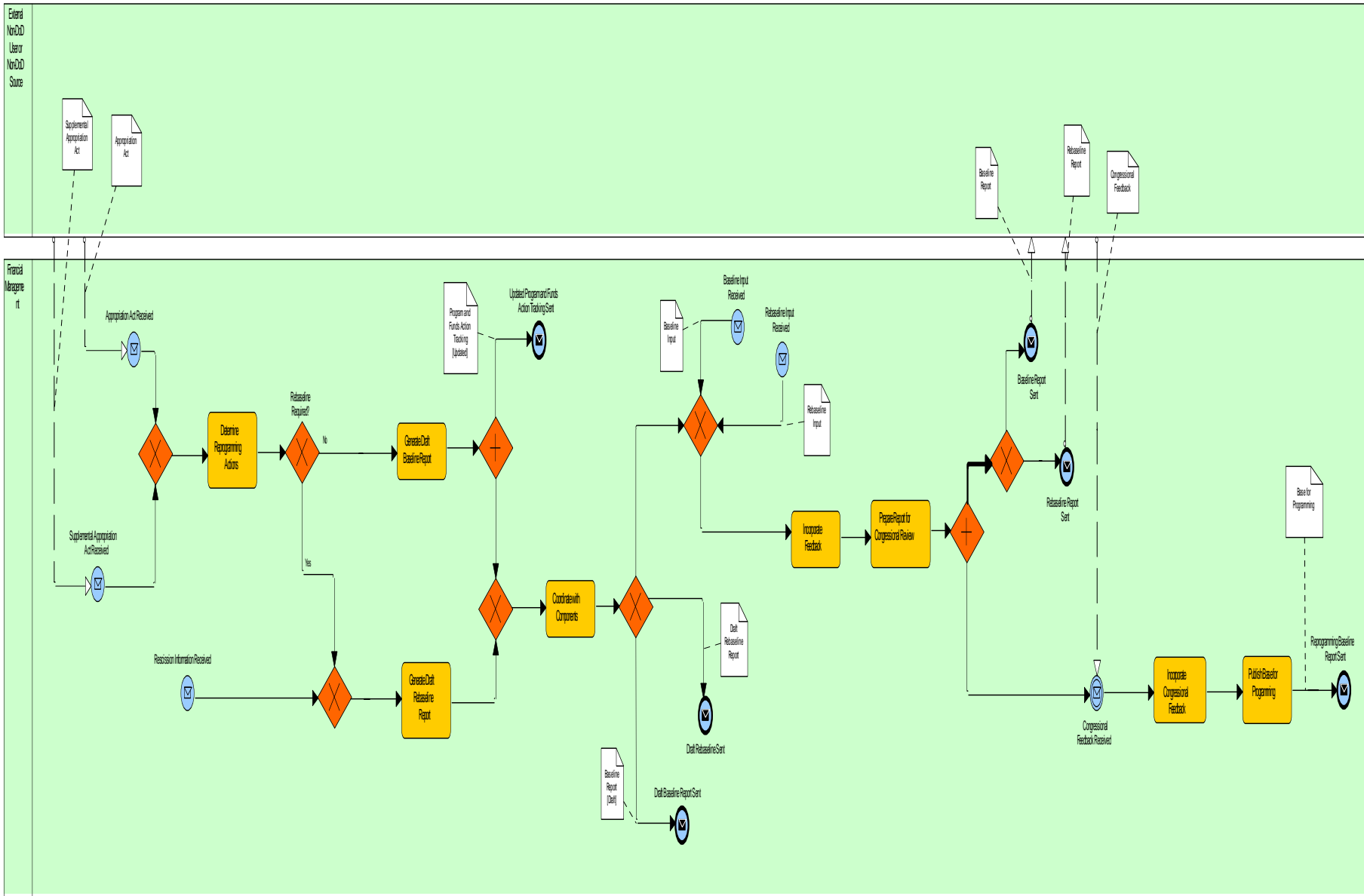

Financial Management

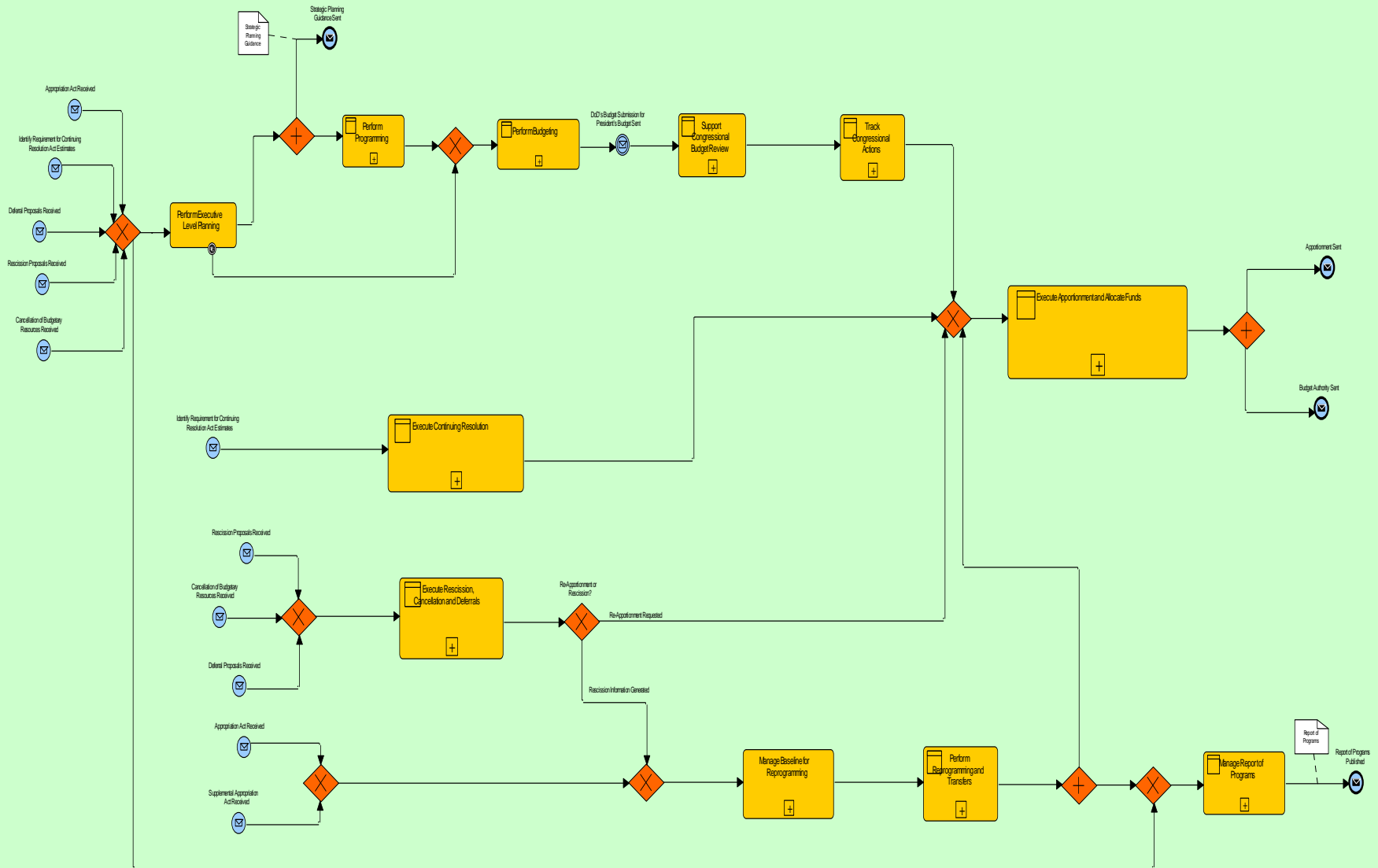

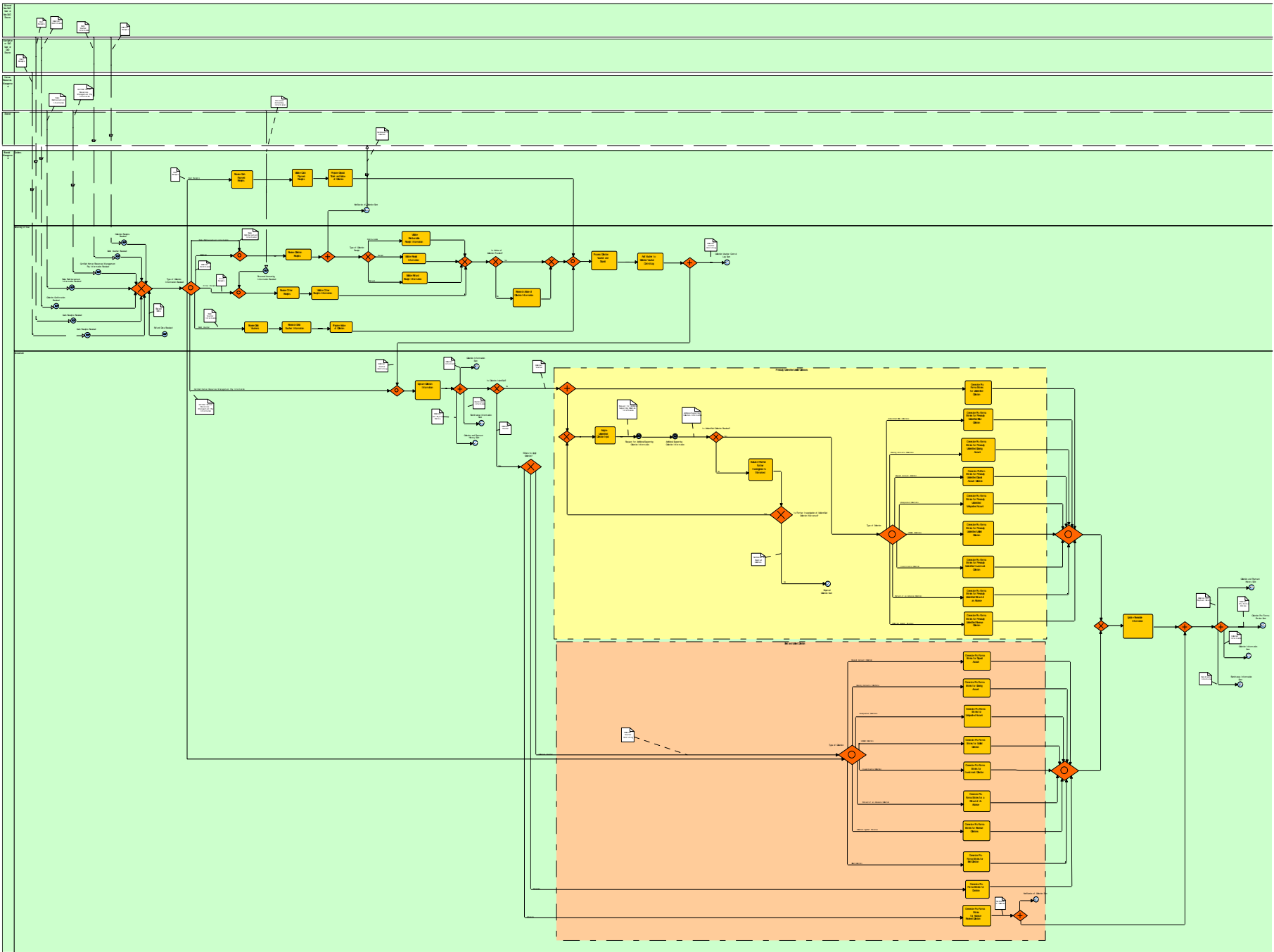

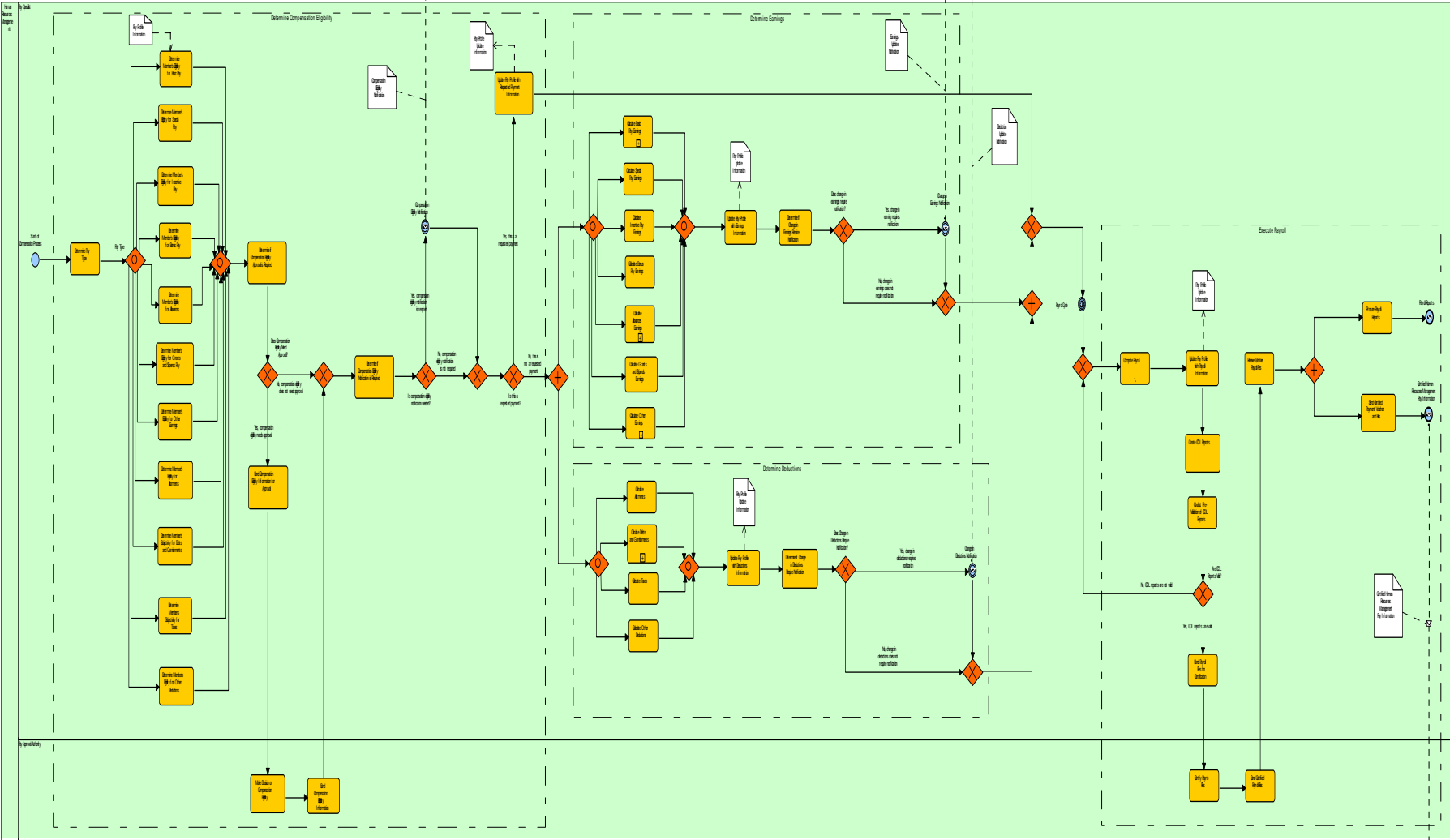
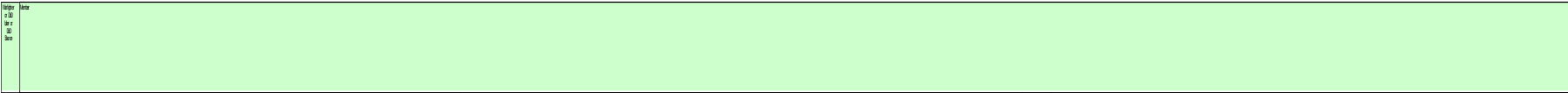

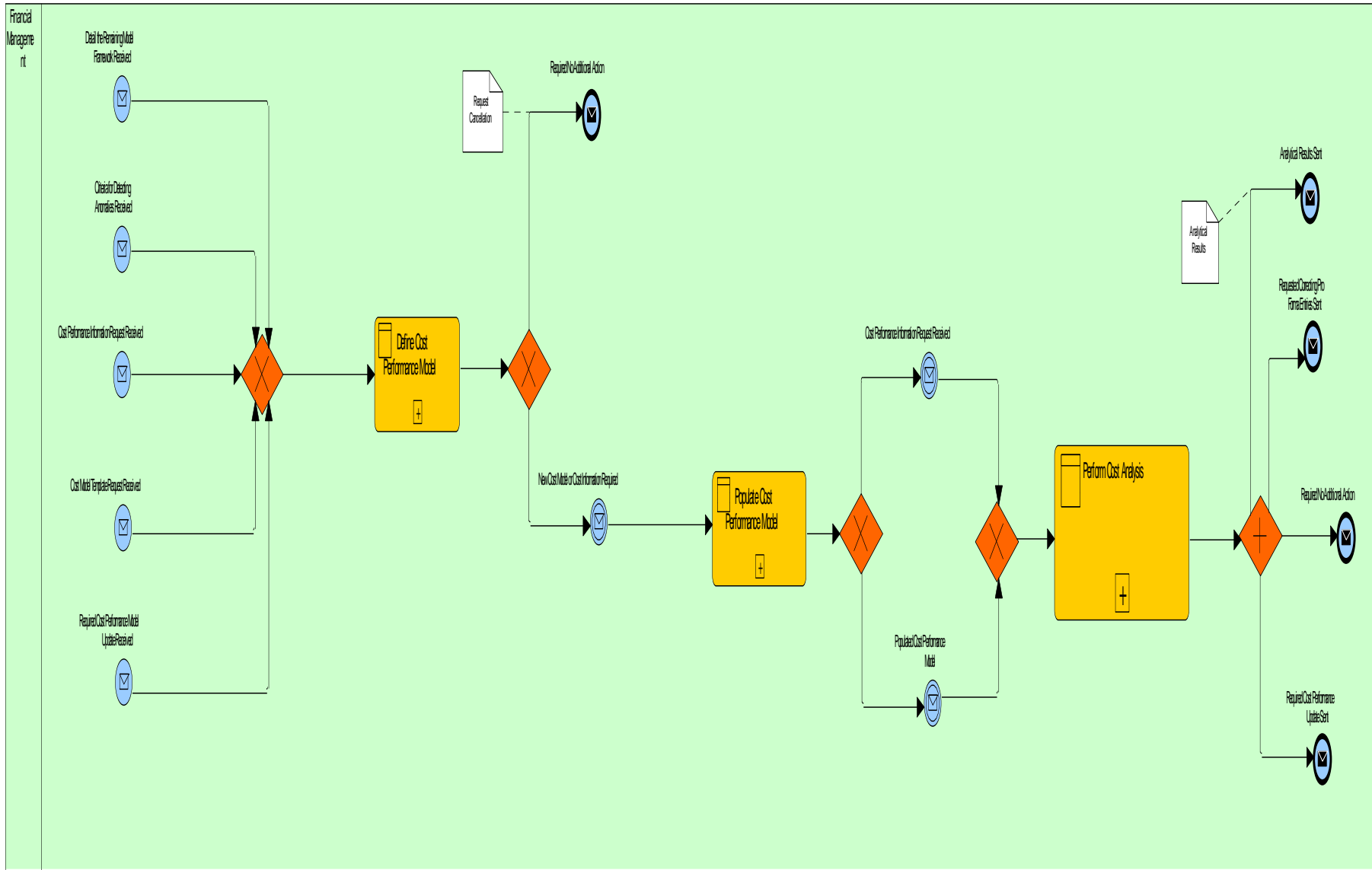

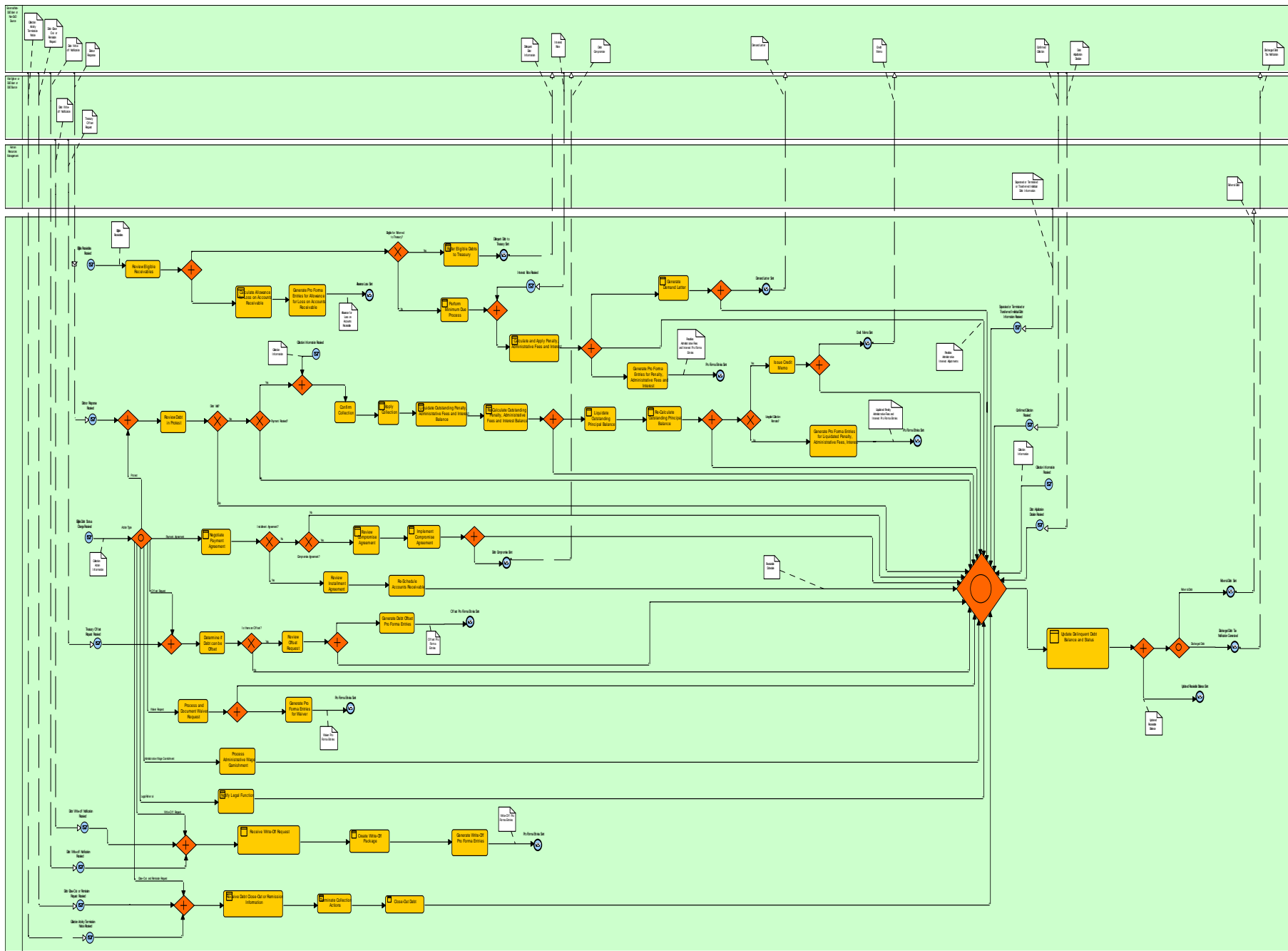

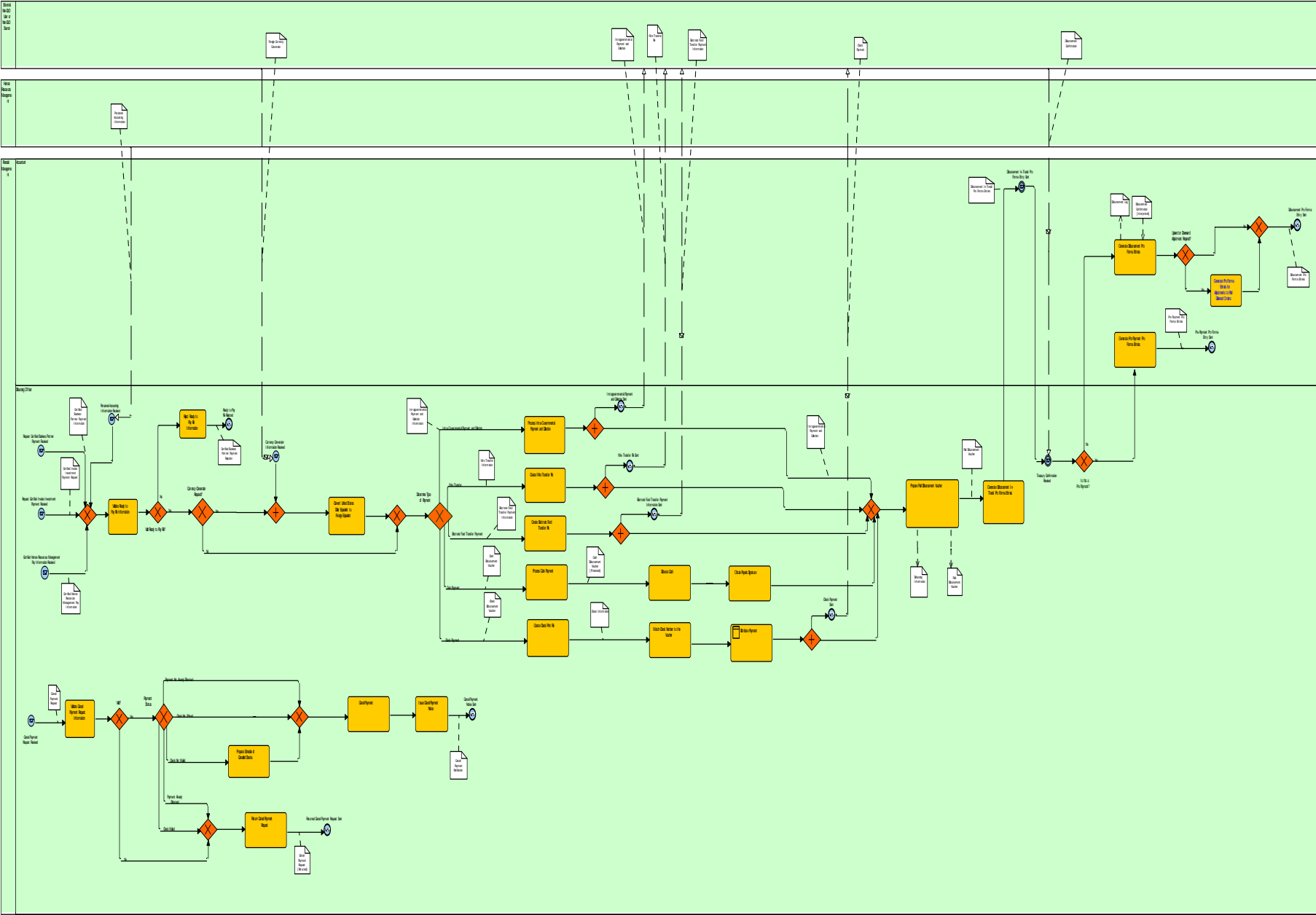

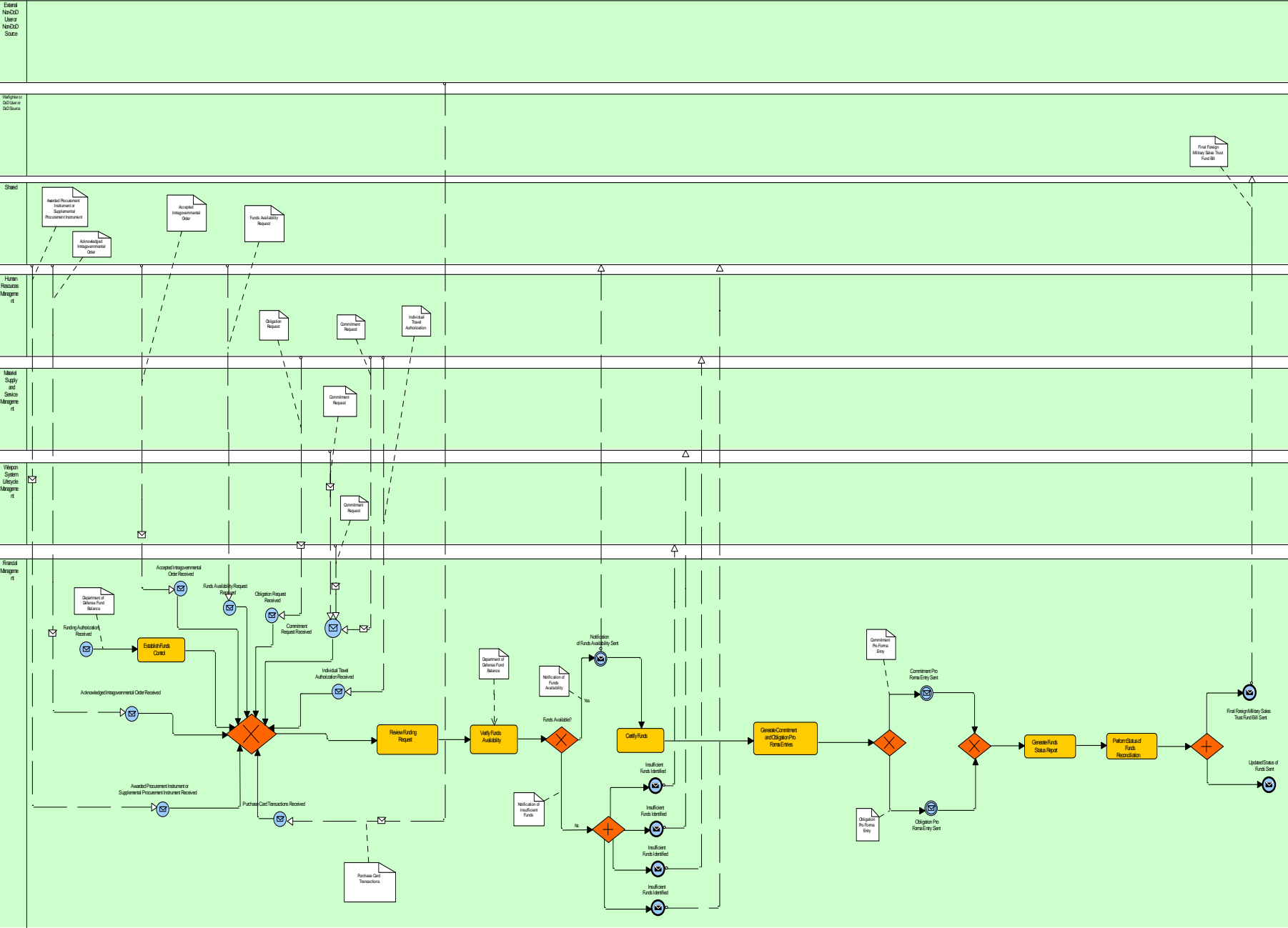

Manage Facility Energy (O&A: Business Process)
 System Architect
 Thursday, February 07, 2013 5:39 PM
 —Comment—
 This process is where energy program managers take all actions needed to manage facility energy reporting, facility energy goals, and facility energy analytics.

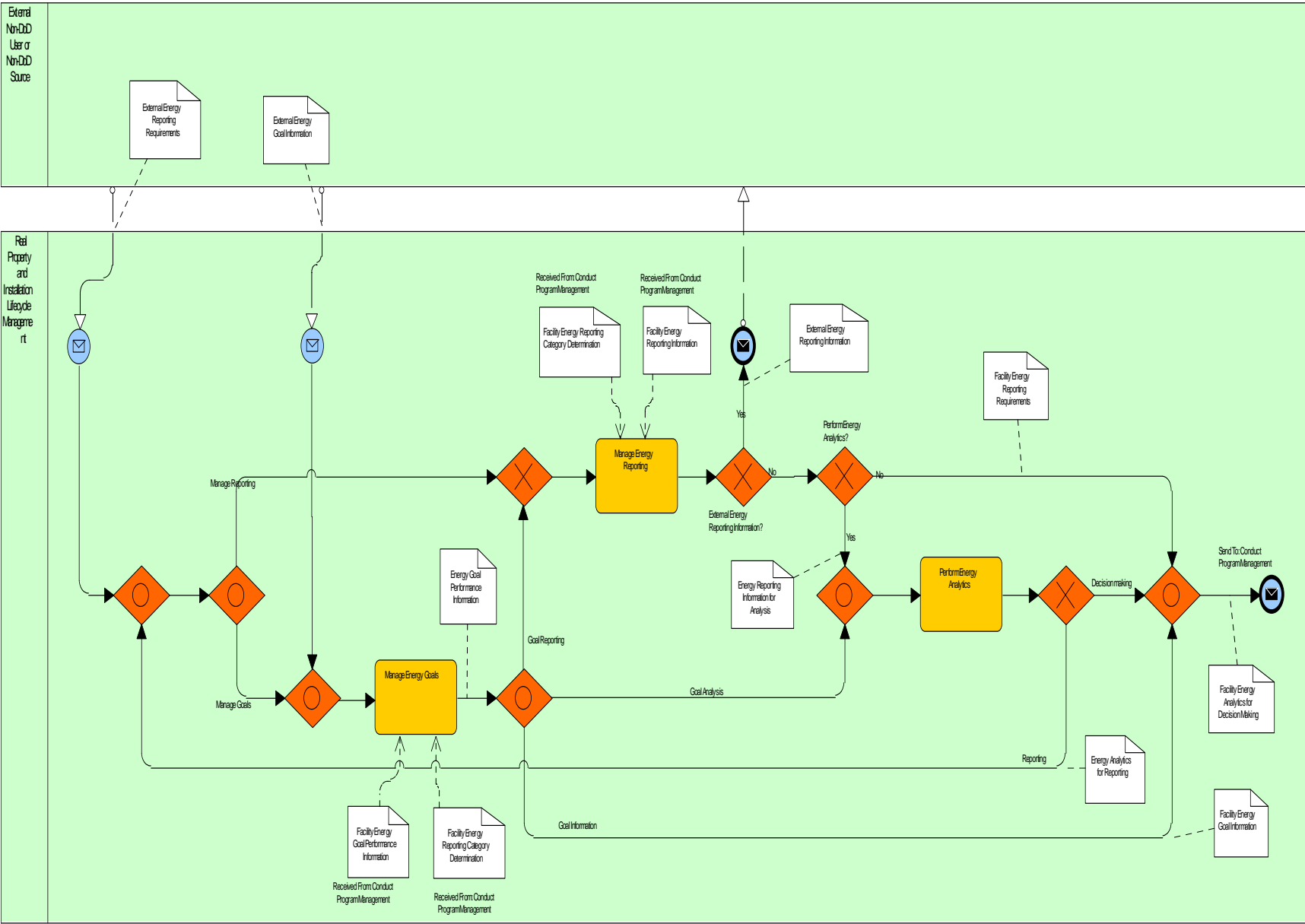

Manage Facility Energy Conservation (OV-6) Business Process
 System Architect
 Thursday, February 07, 2013 4:40 PM

This process is where energy managers take all actions needed to manage facility energy conservation, including performance of facility energy reviews, selecting energy conservation measures to implement, determining energy conservation measure implementation schedules, and performing energy project measurement and verification.

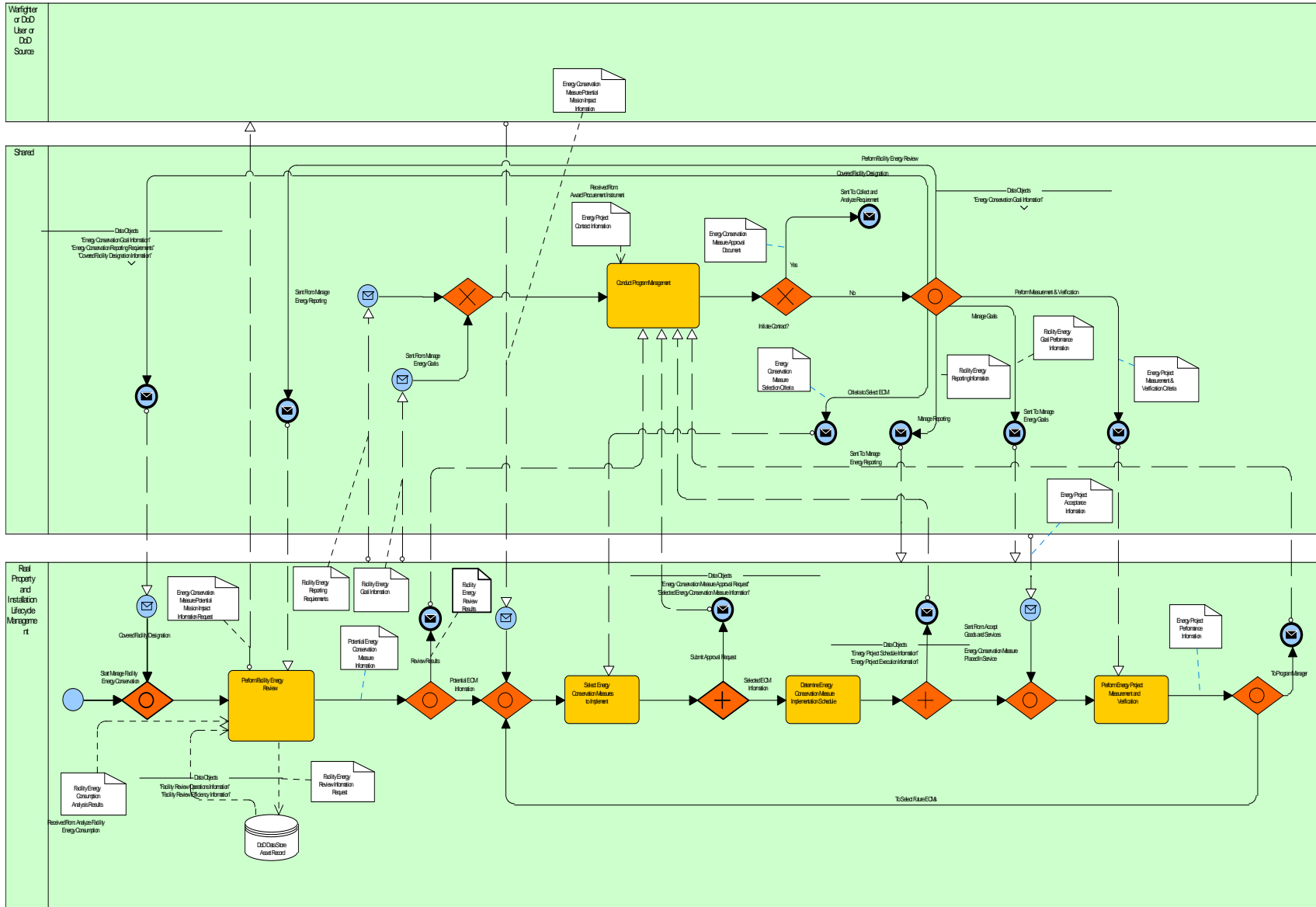

Manage Facility Energy Consumption (O/6c Business Process)
 System Architect
 Thursday, February 07, 2013 4:59 PM
 Comment
 This process is where energy managers take all actions needed to manage facility energy consumption, including determination of facility energy consumption parameters, recording facility energy consumption, and analyzing facility energy consumption.

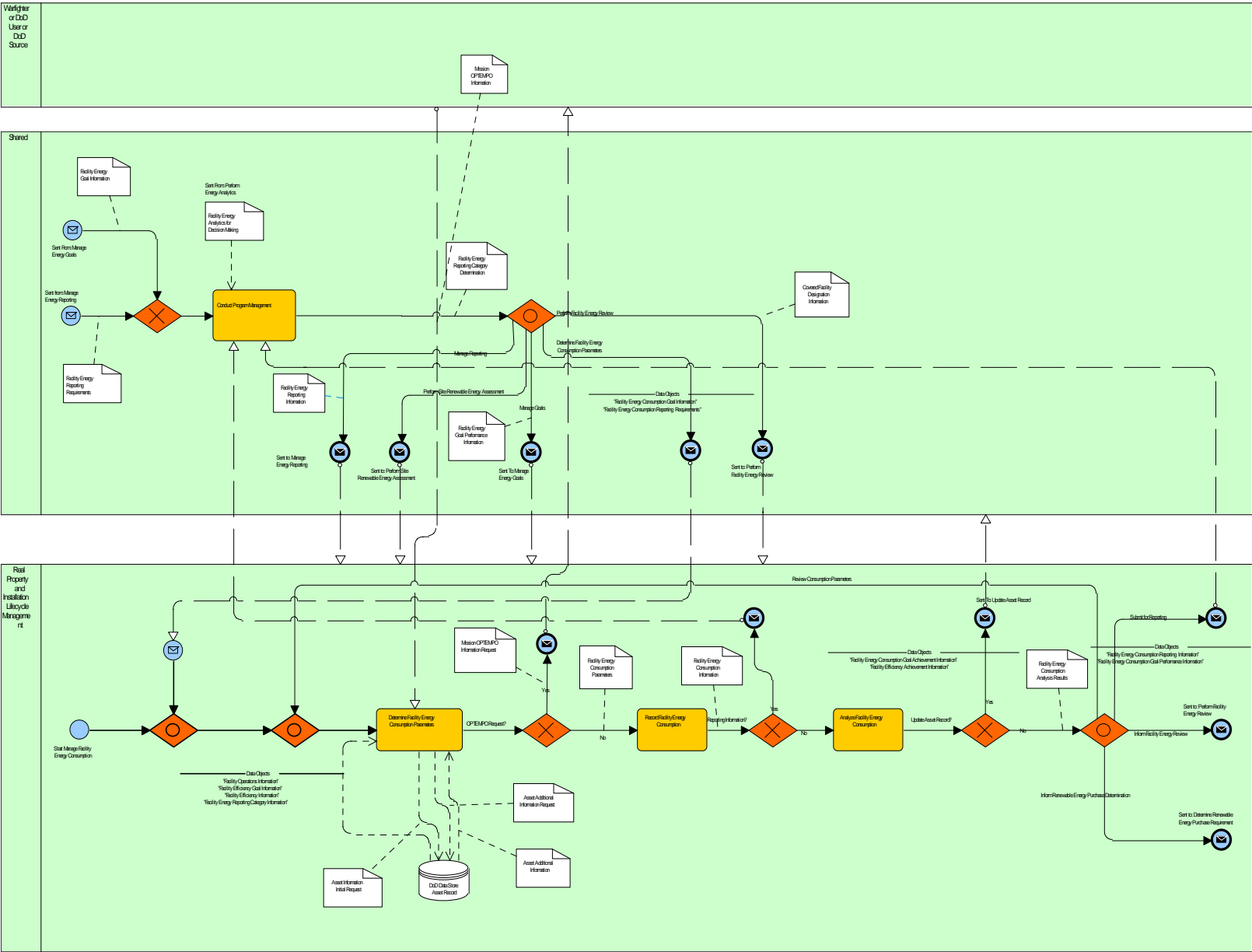

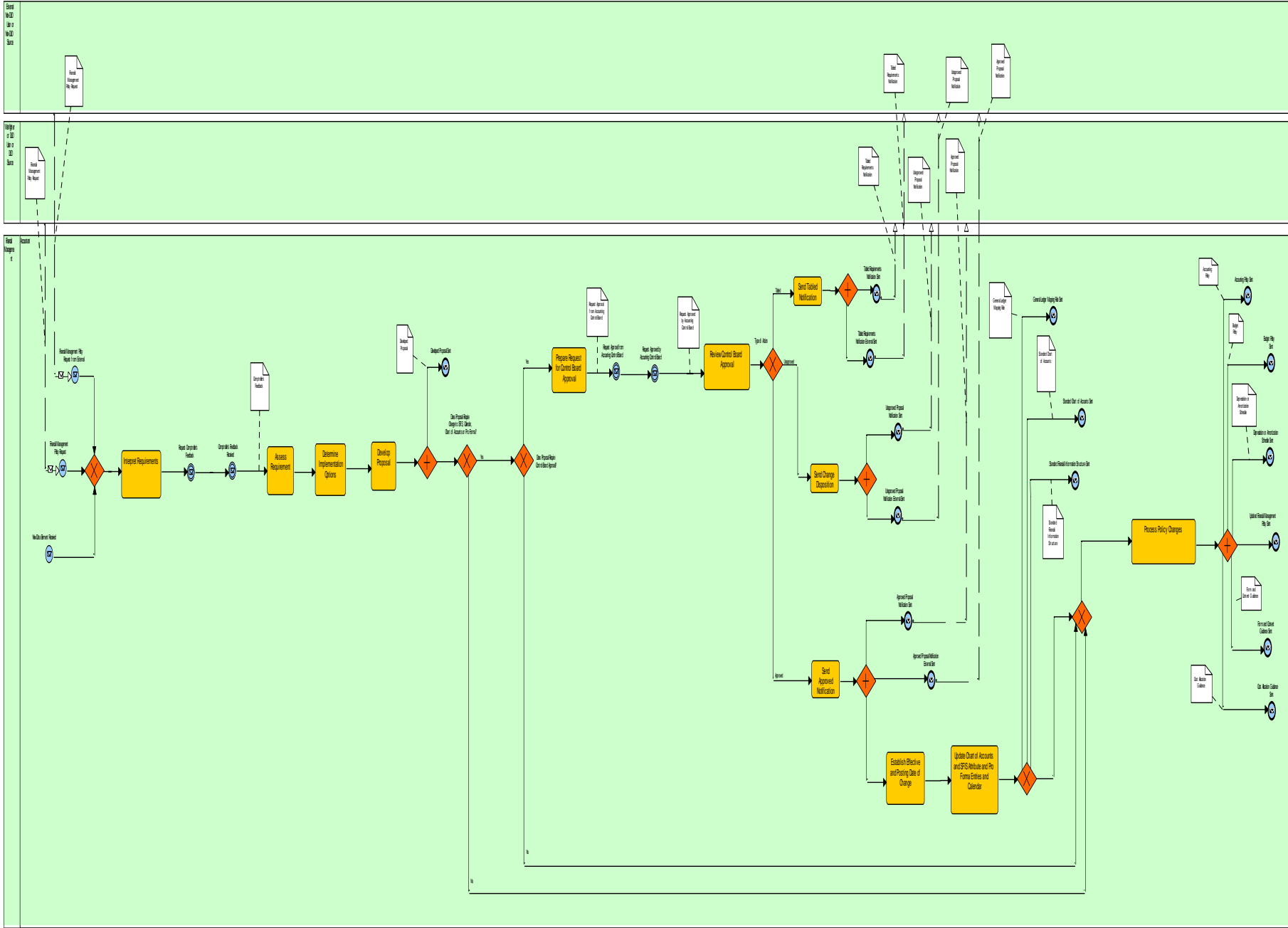

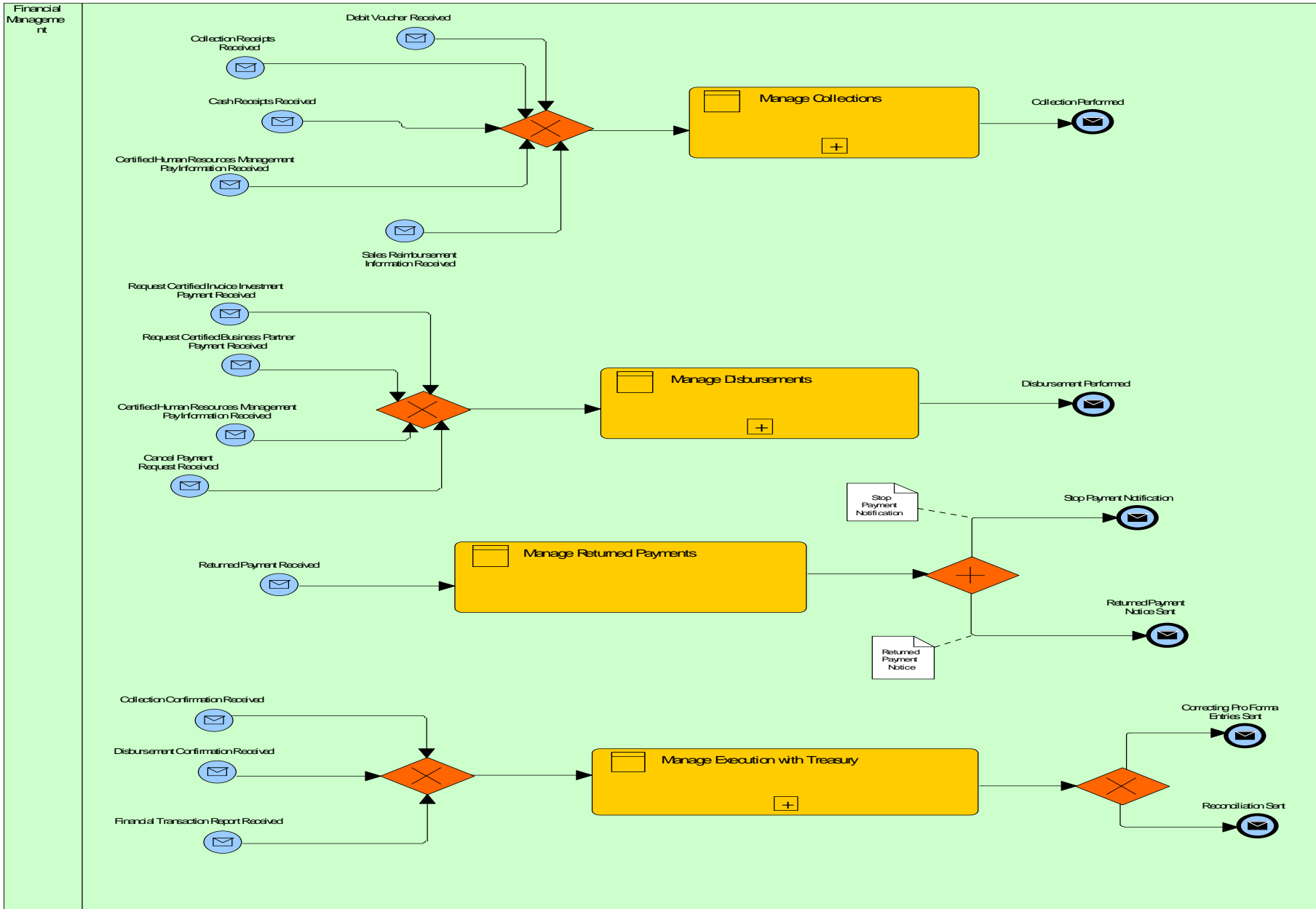

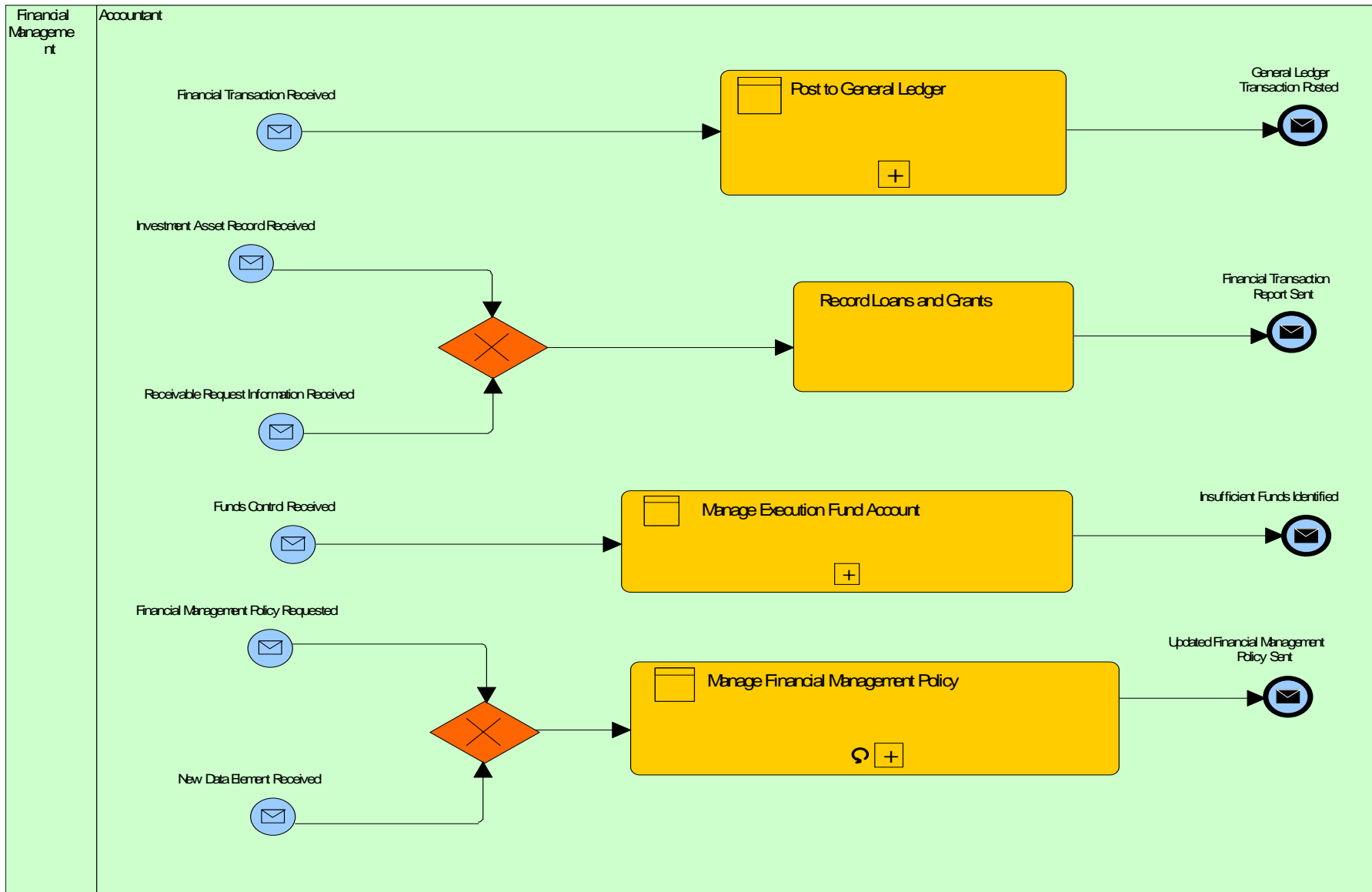

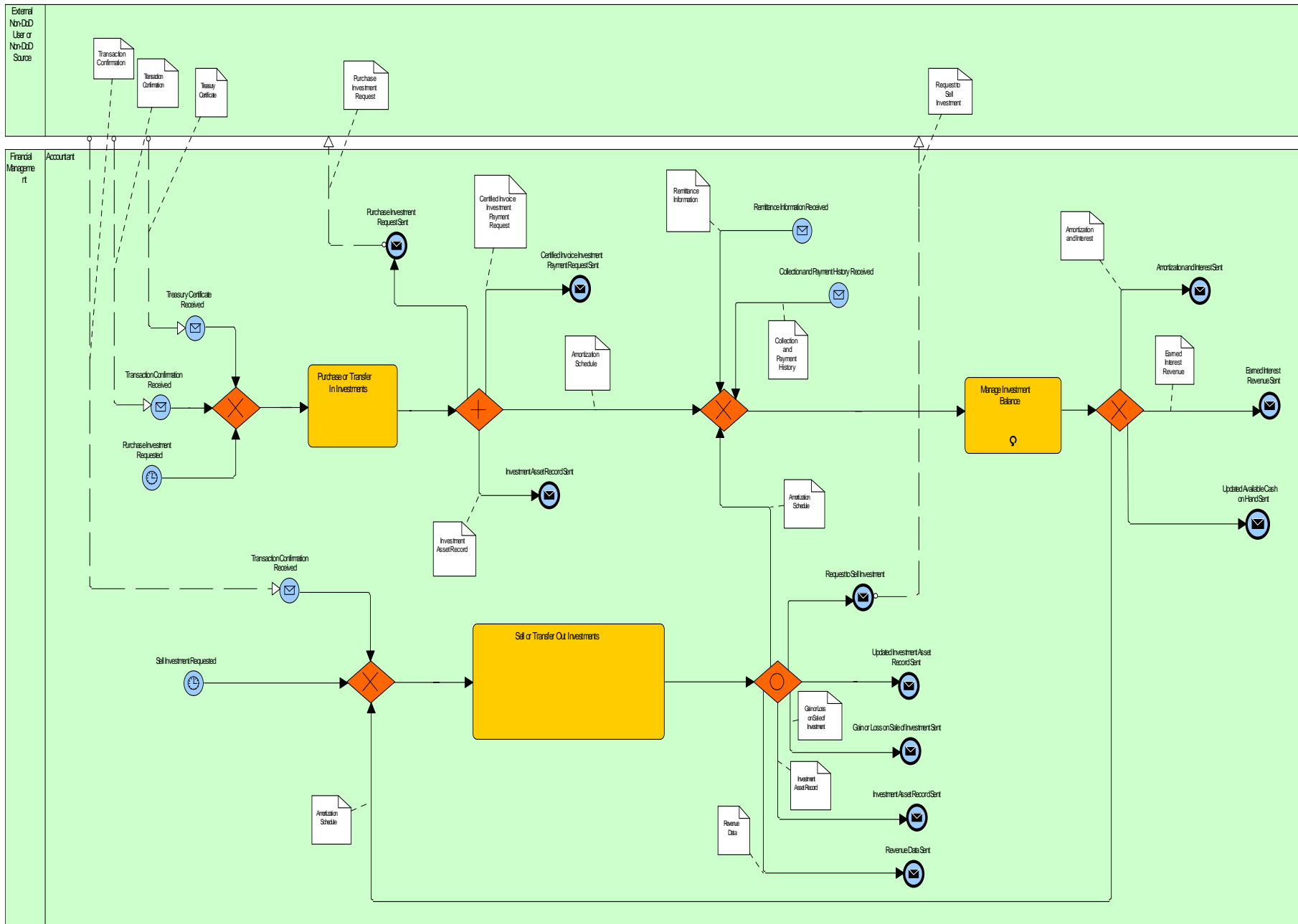

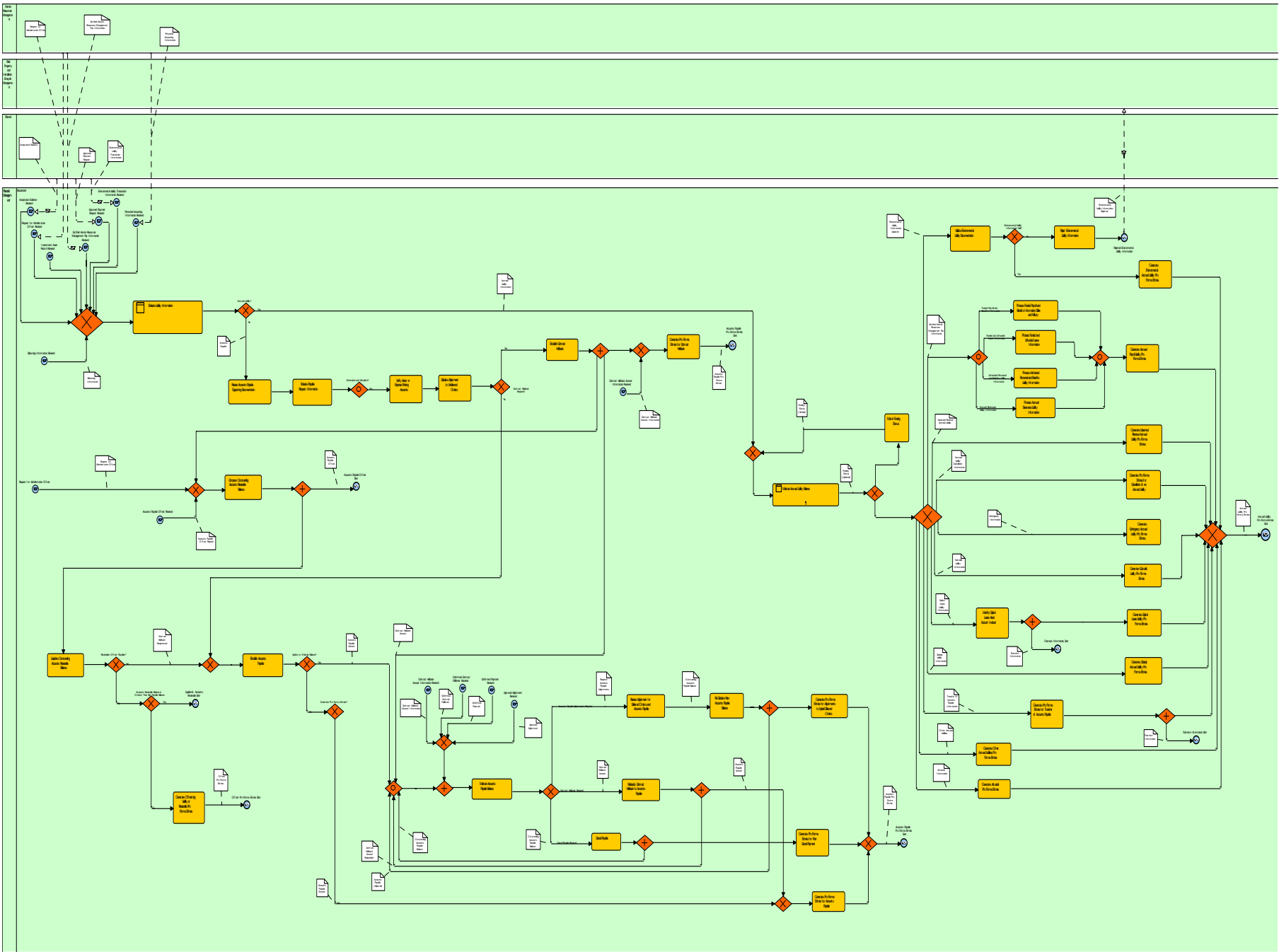

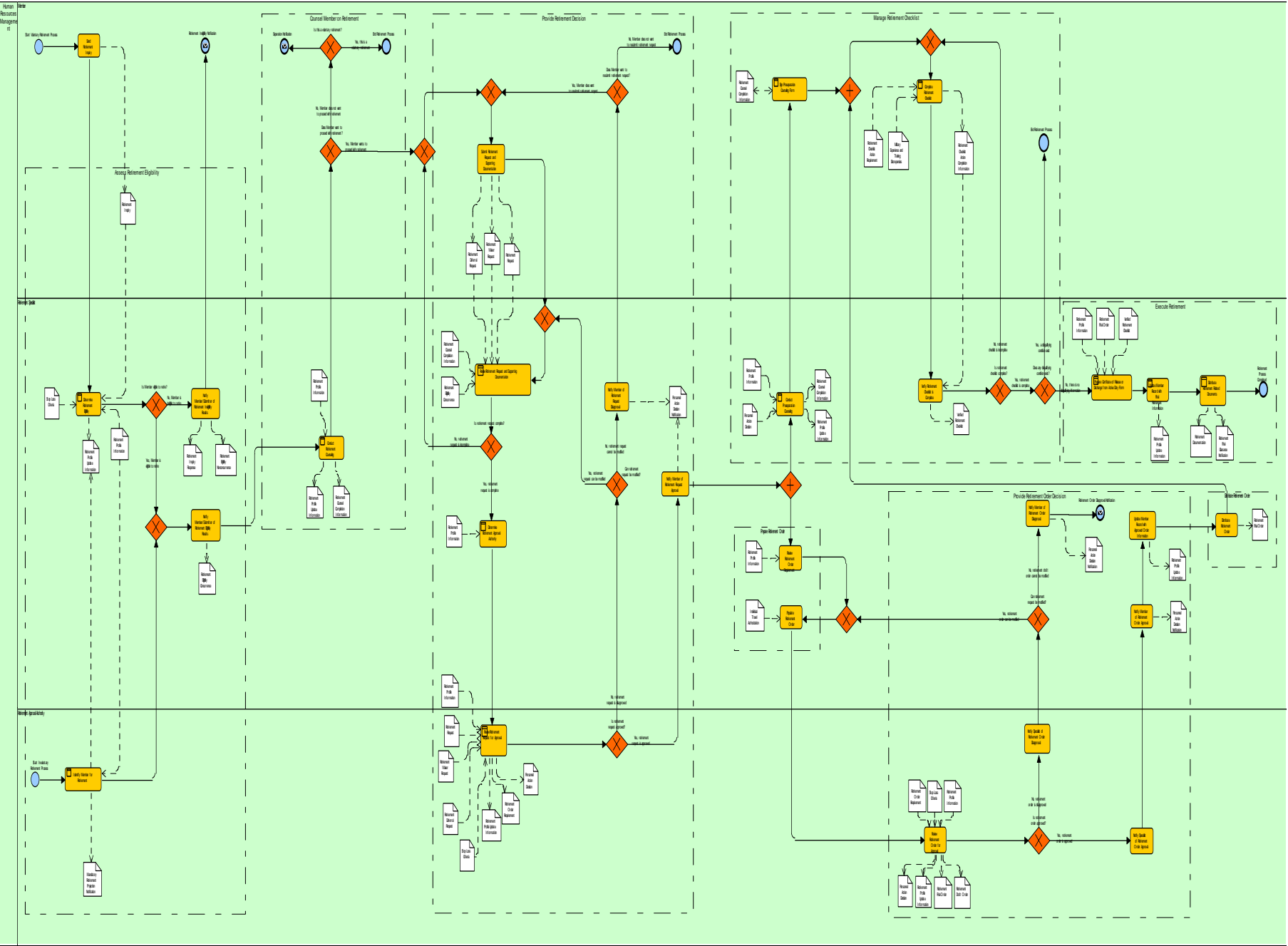

Financial Management

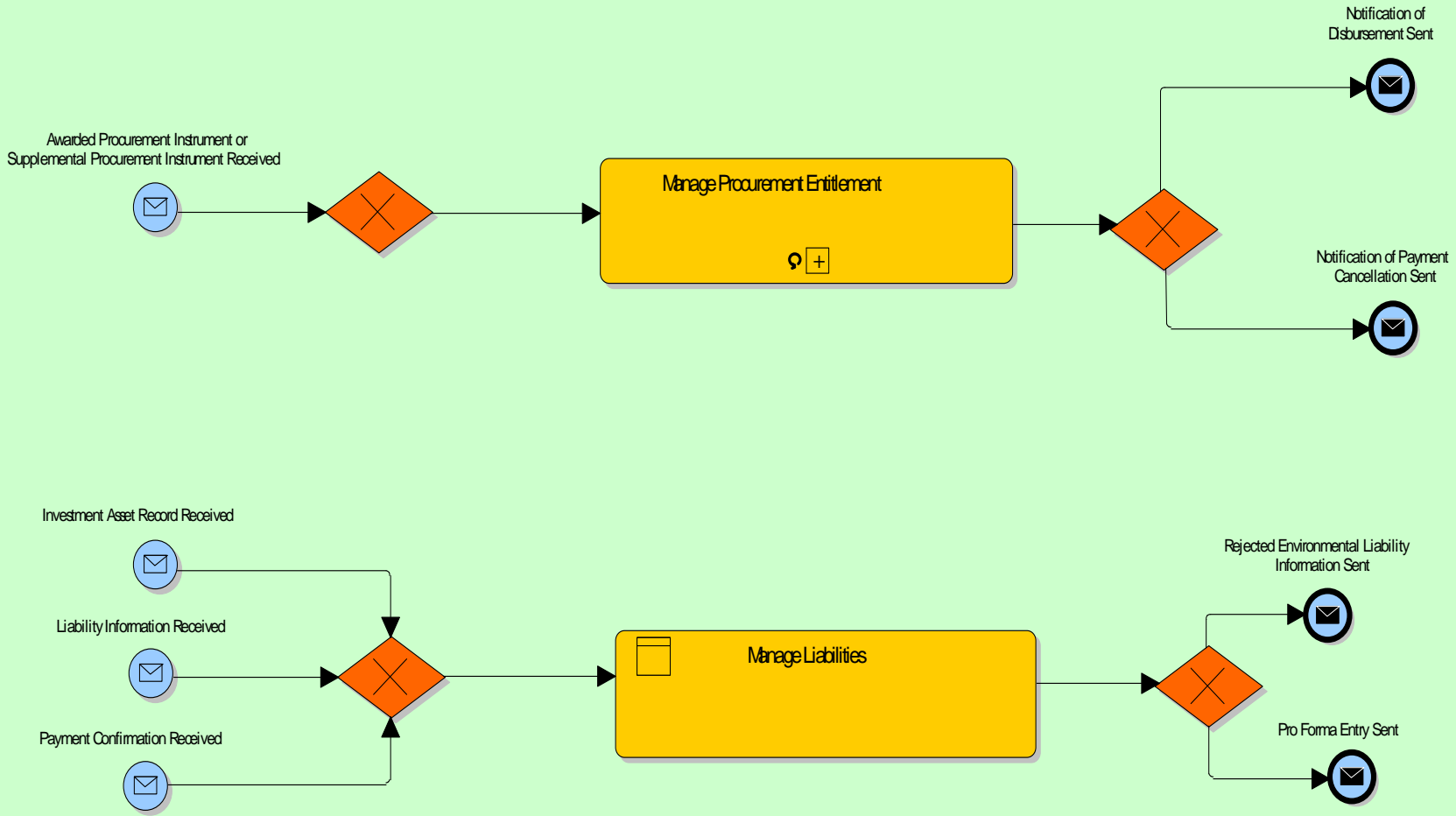

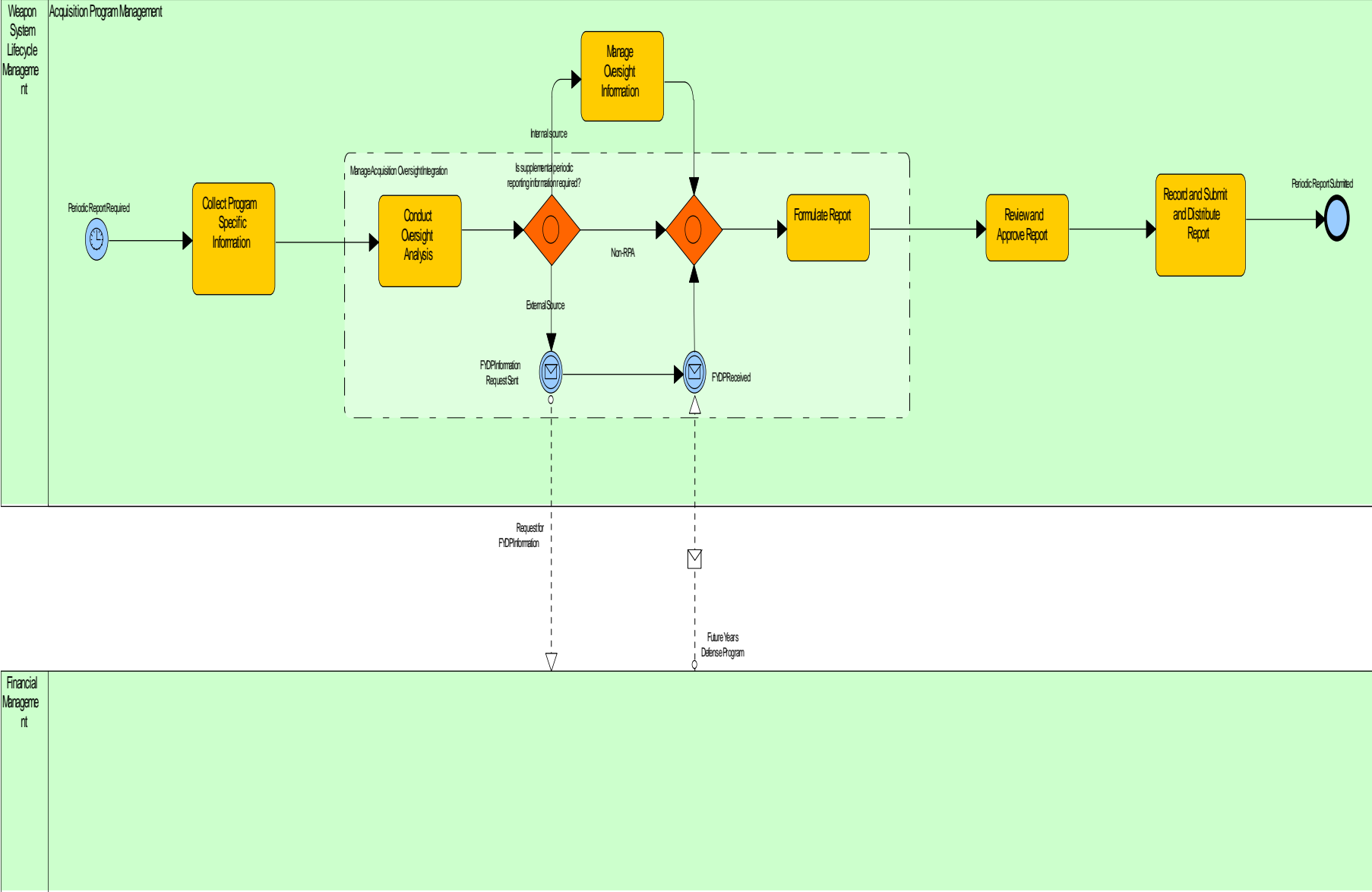

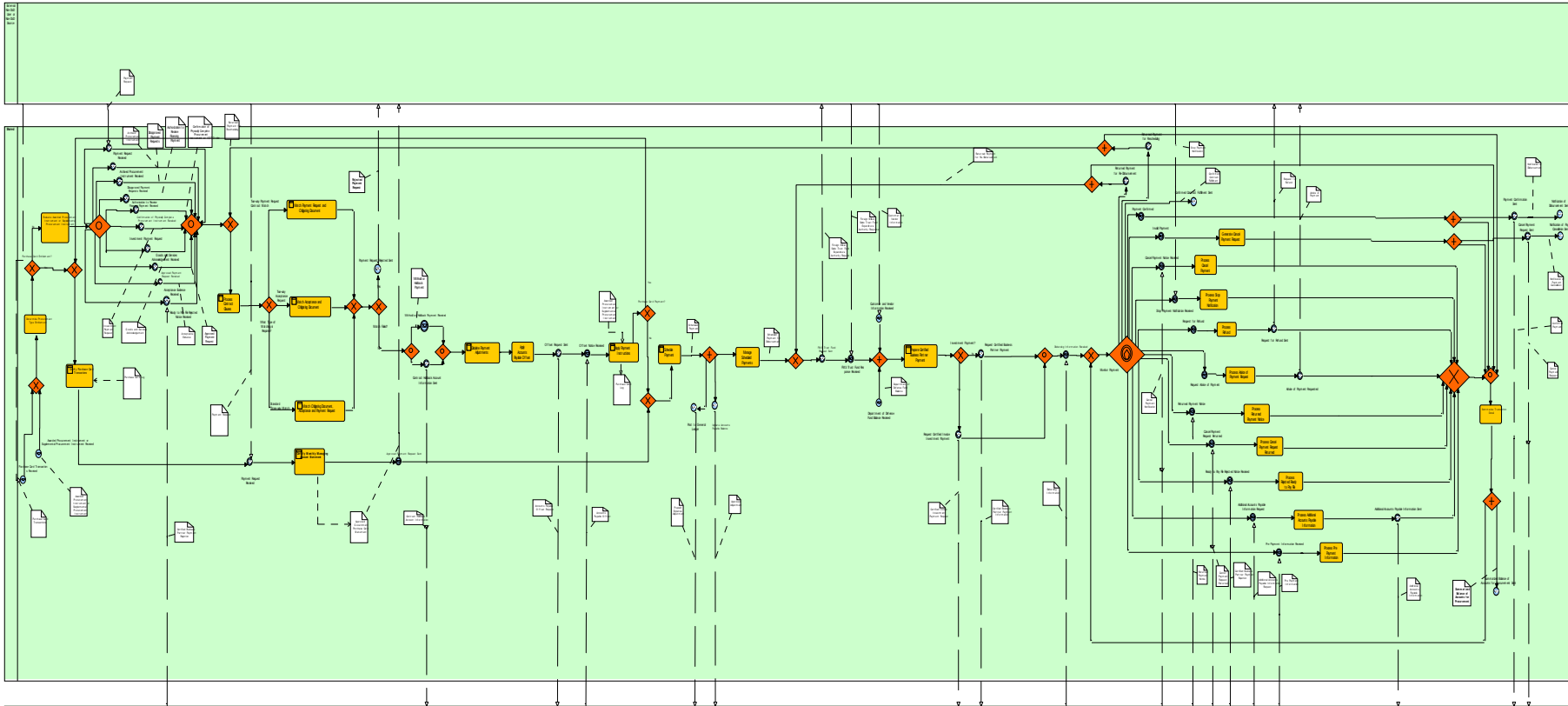

[This diagram is part of the procurement KPI/OA deck for BEA90. The deck is available on P2 and will be updated by E2 when Q4 data is done.](#)

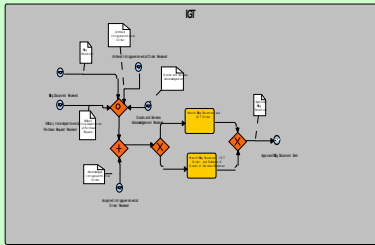

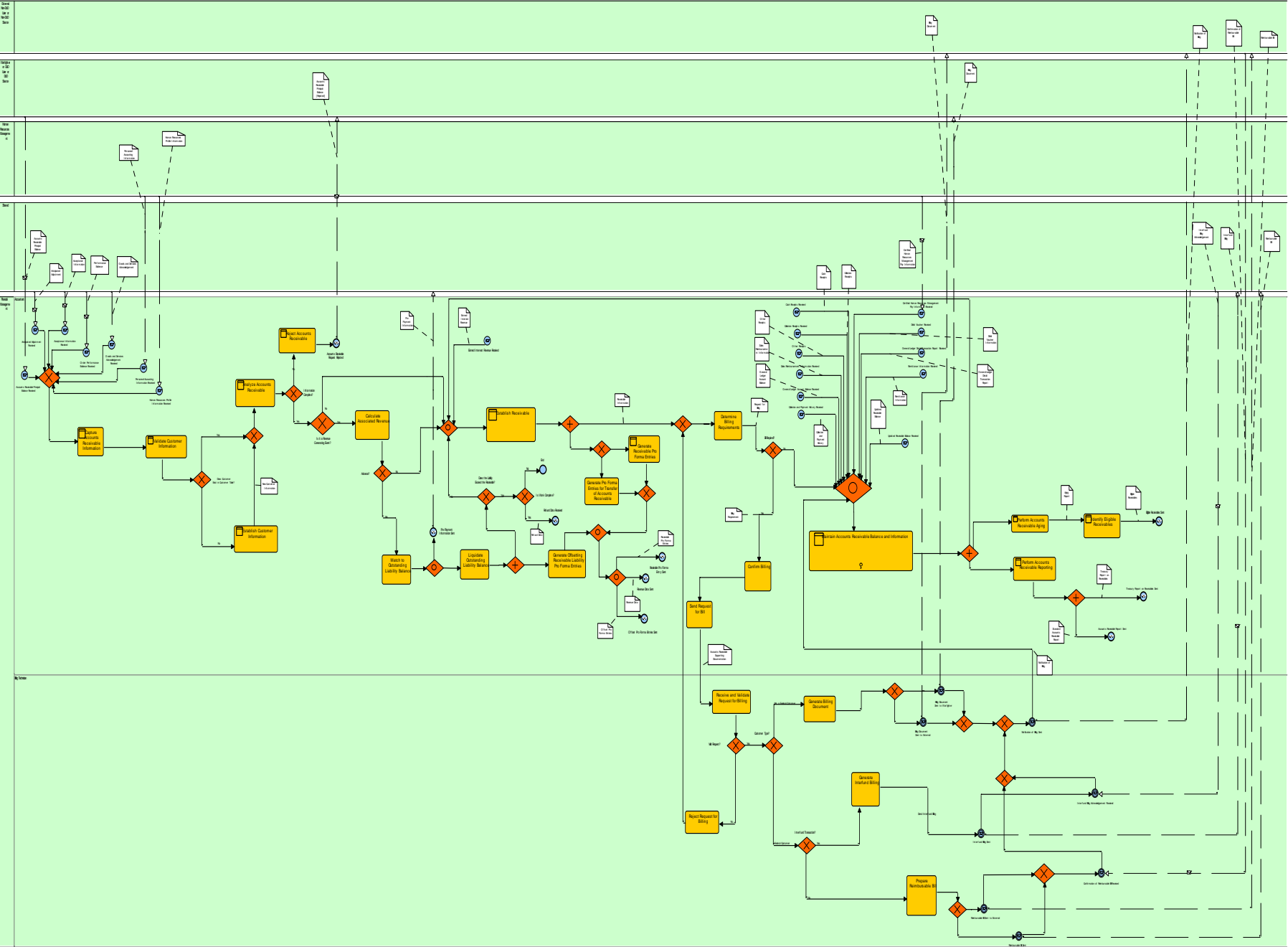

Manage Renewable Energy Production and Purchase (O/R) Business Process
 System Architect
 Thursday, February 07, 2013 5:51 PM

This activity is where energy managers take actions needed to manage renewable energy production and purchase including performance of site renewable energy reviews, selecting renewable energy projects, implementing renewable energy projects, schedules, performing energy project measurement and verification, determining renewable energy purchase requirements, and managing renewable energy purchases.

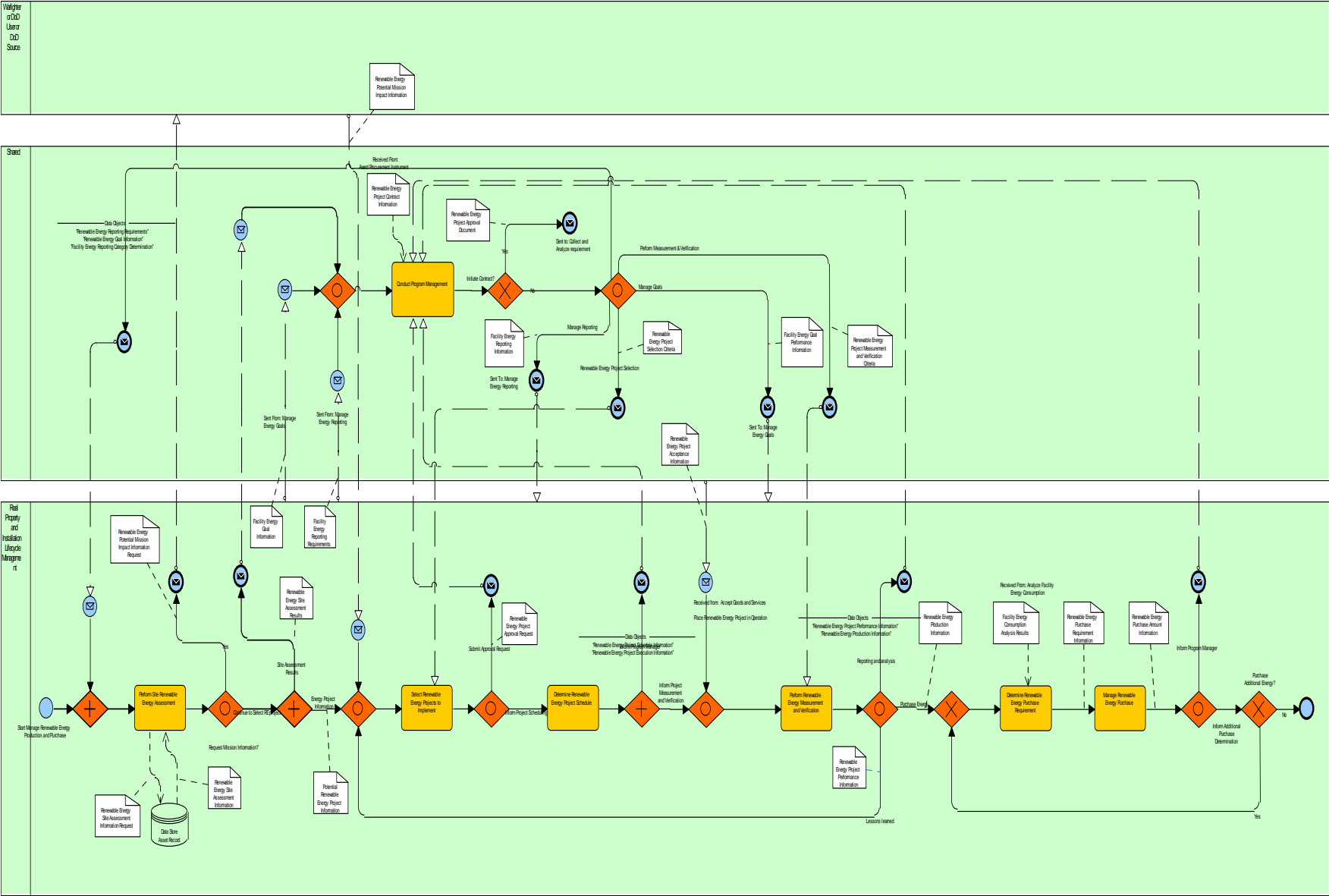

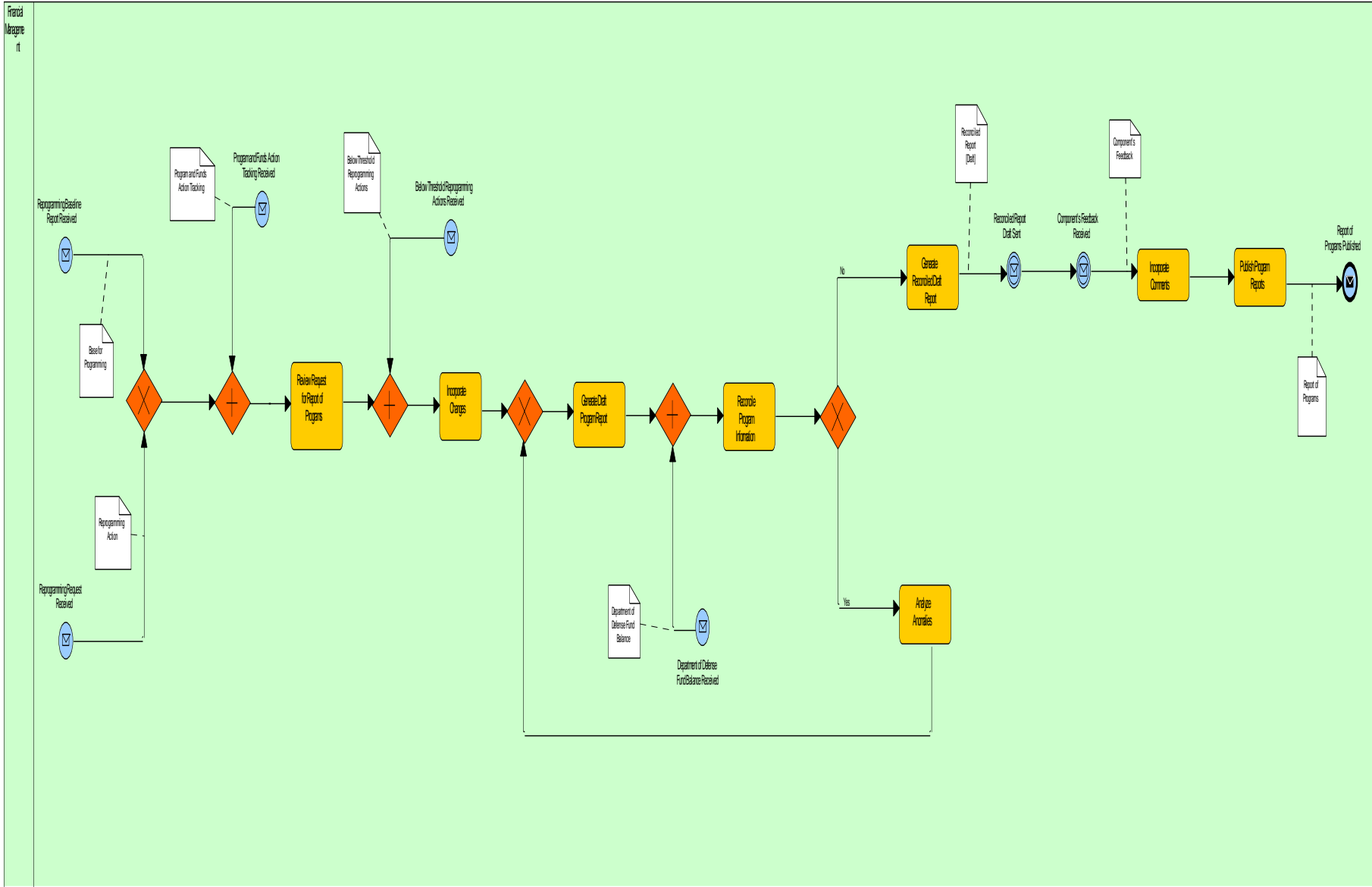

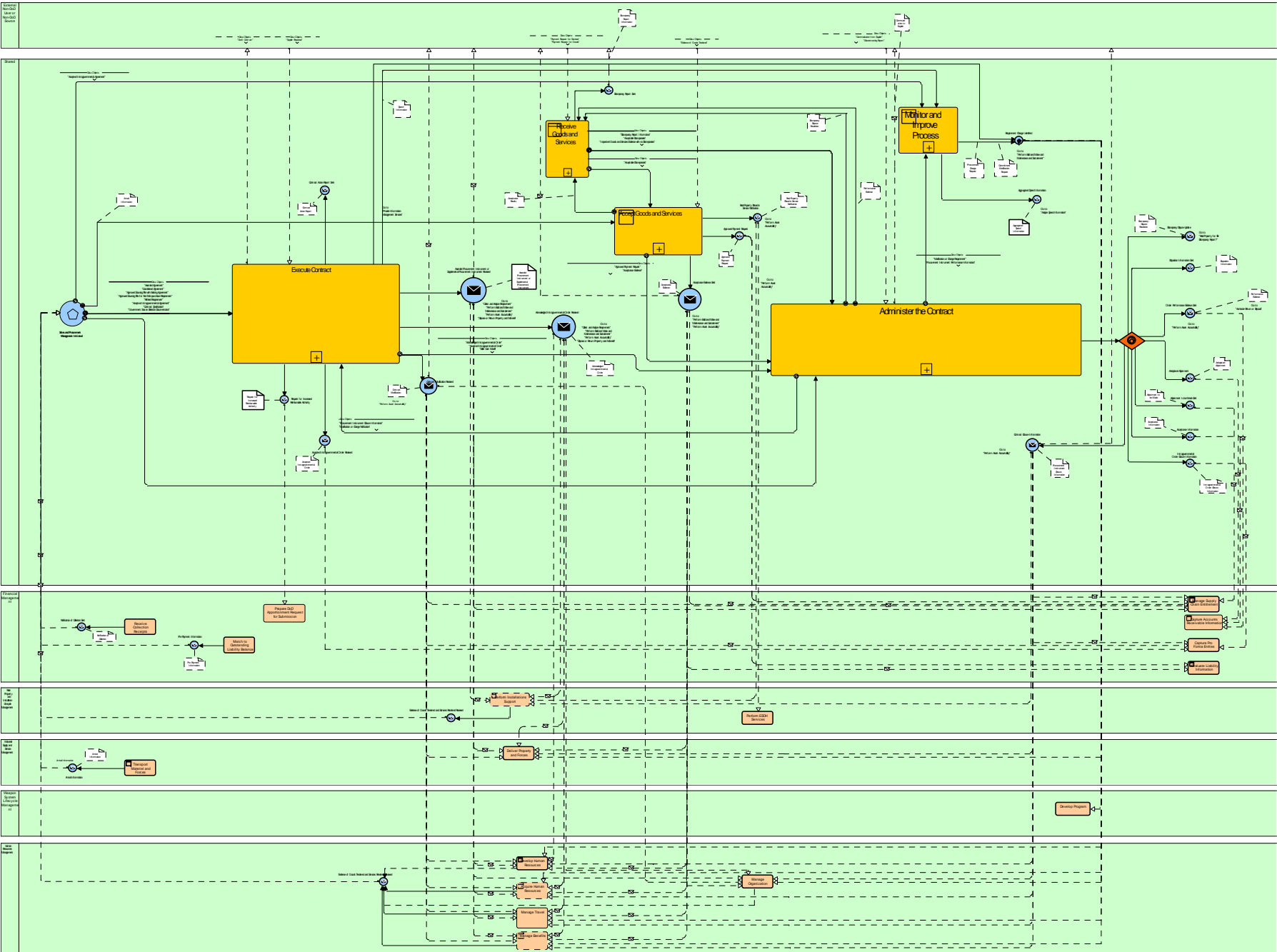

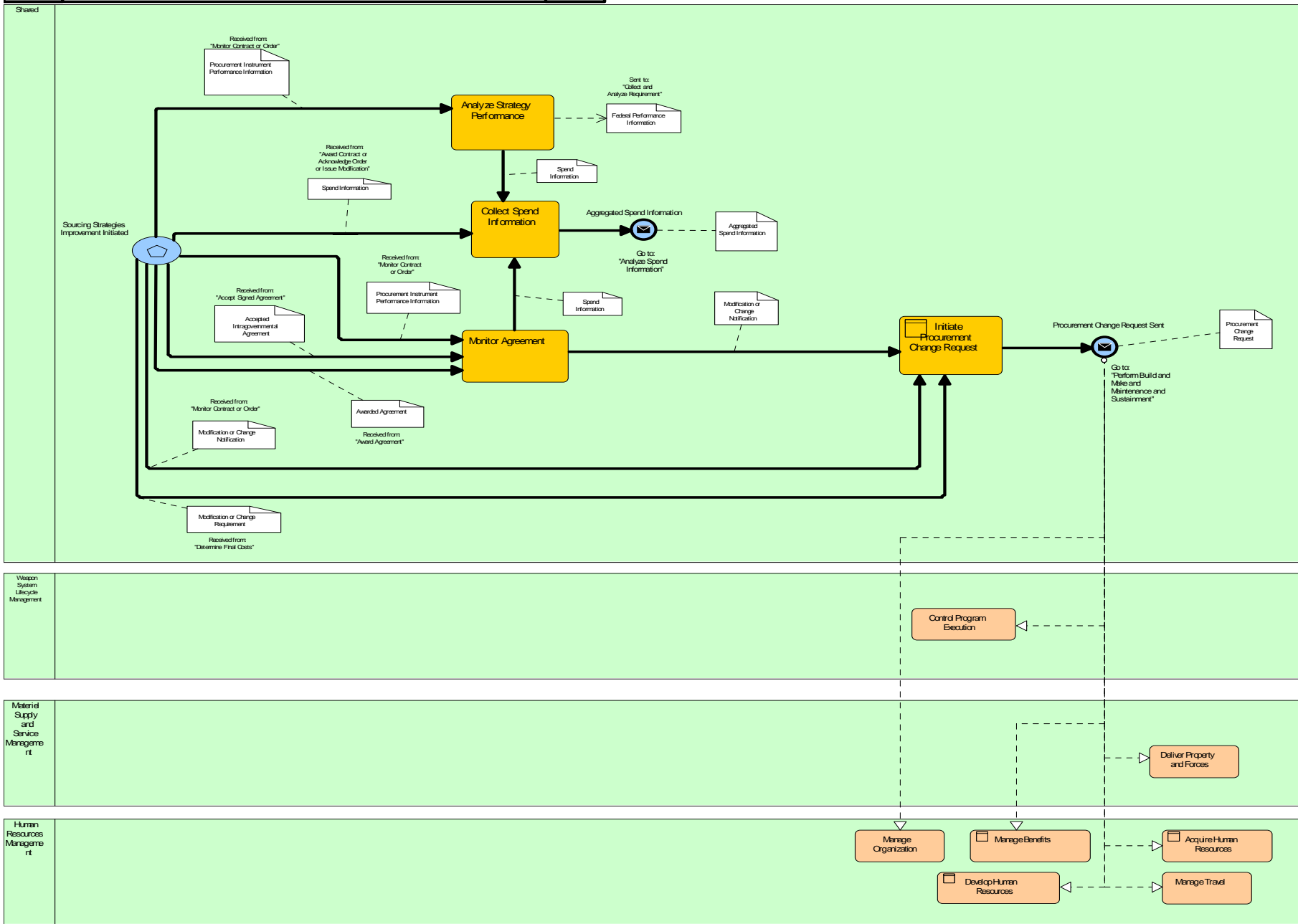

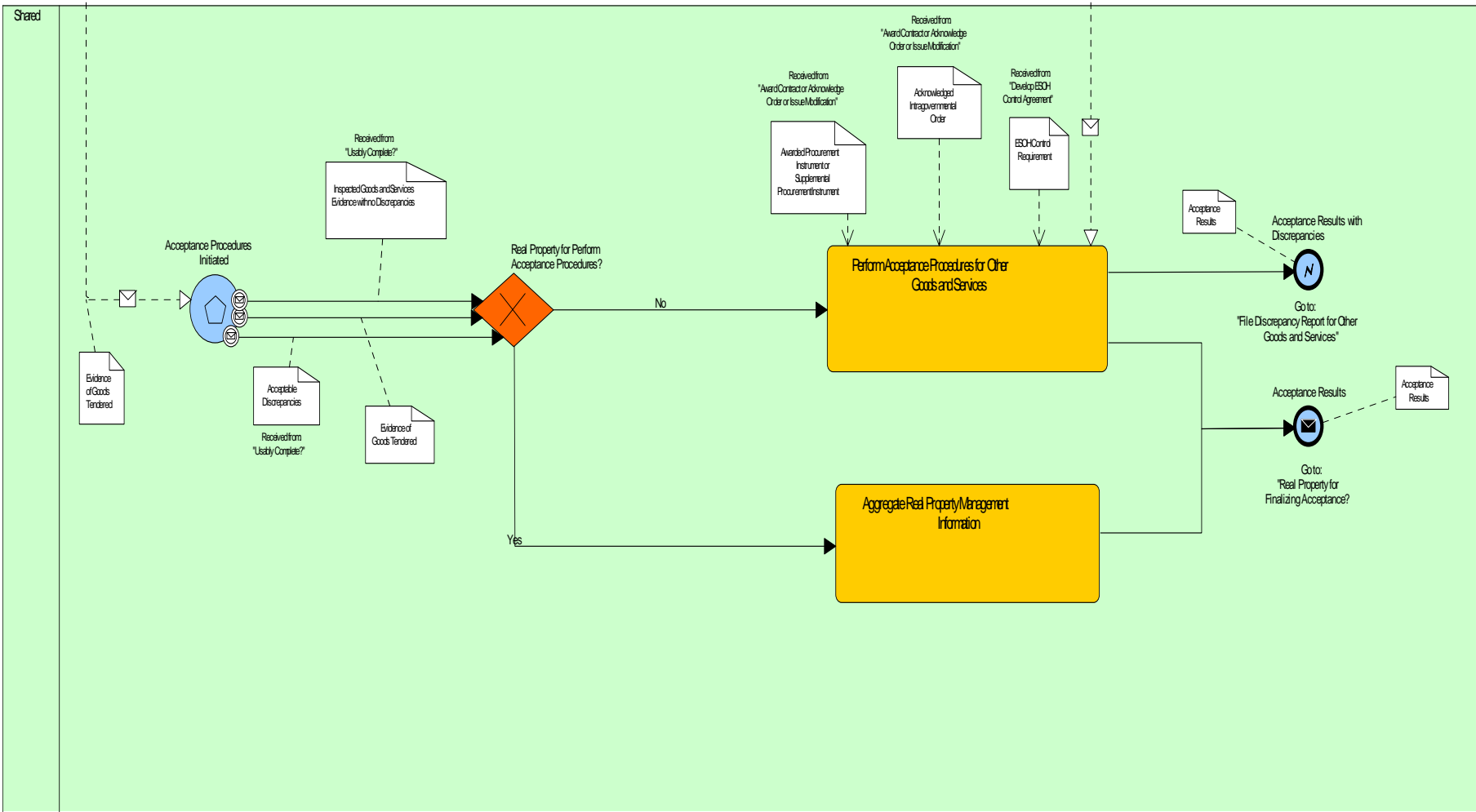
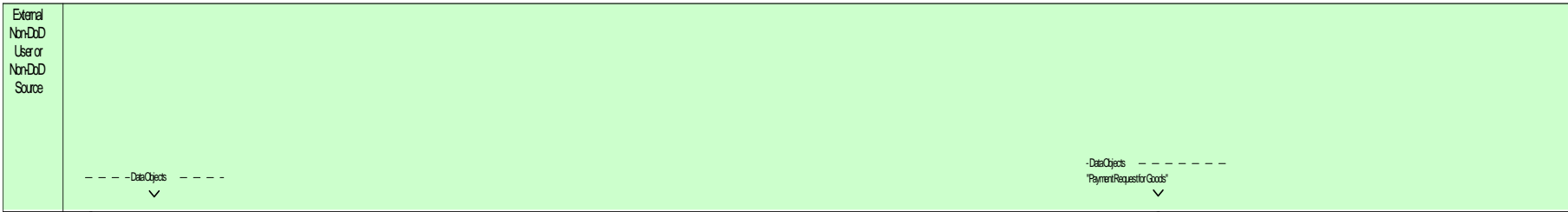

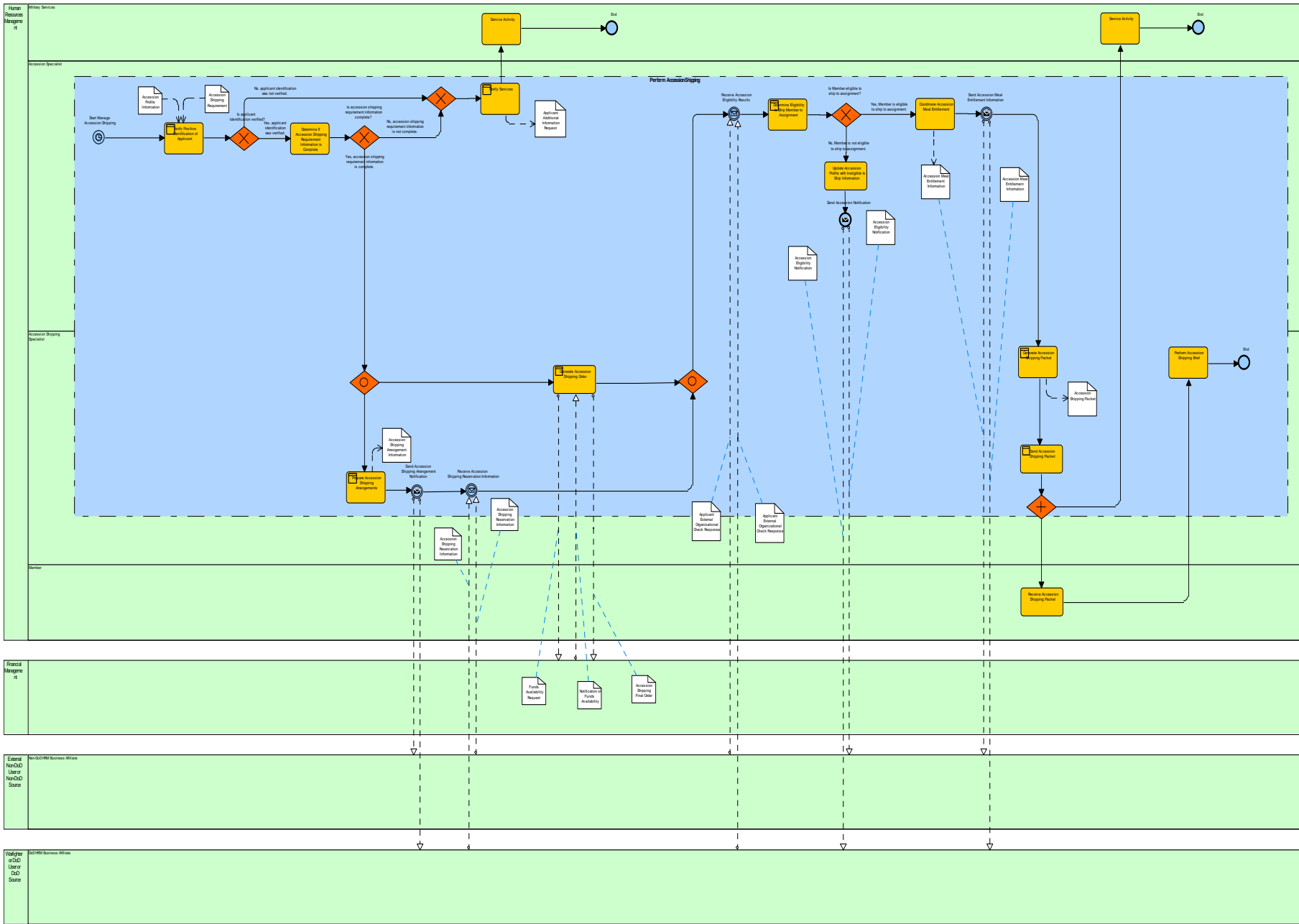

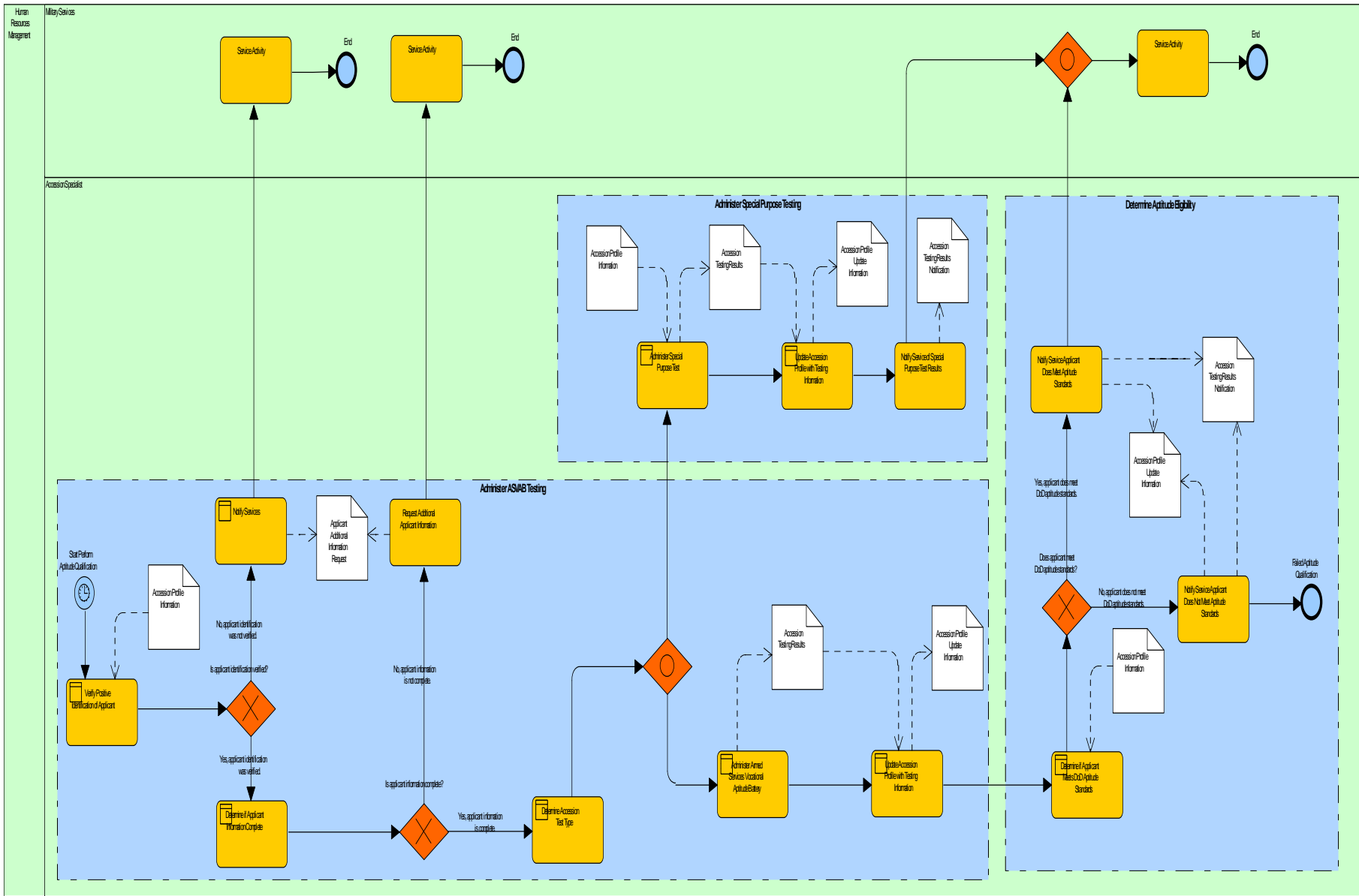

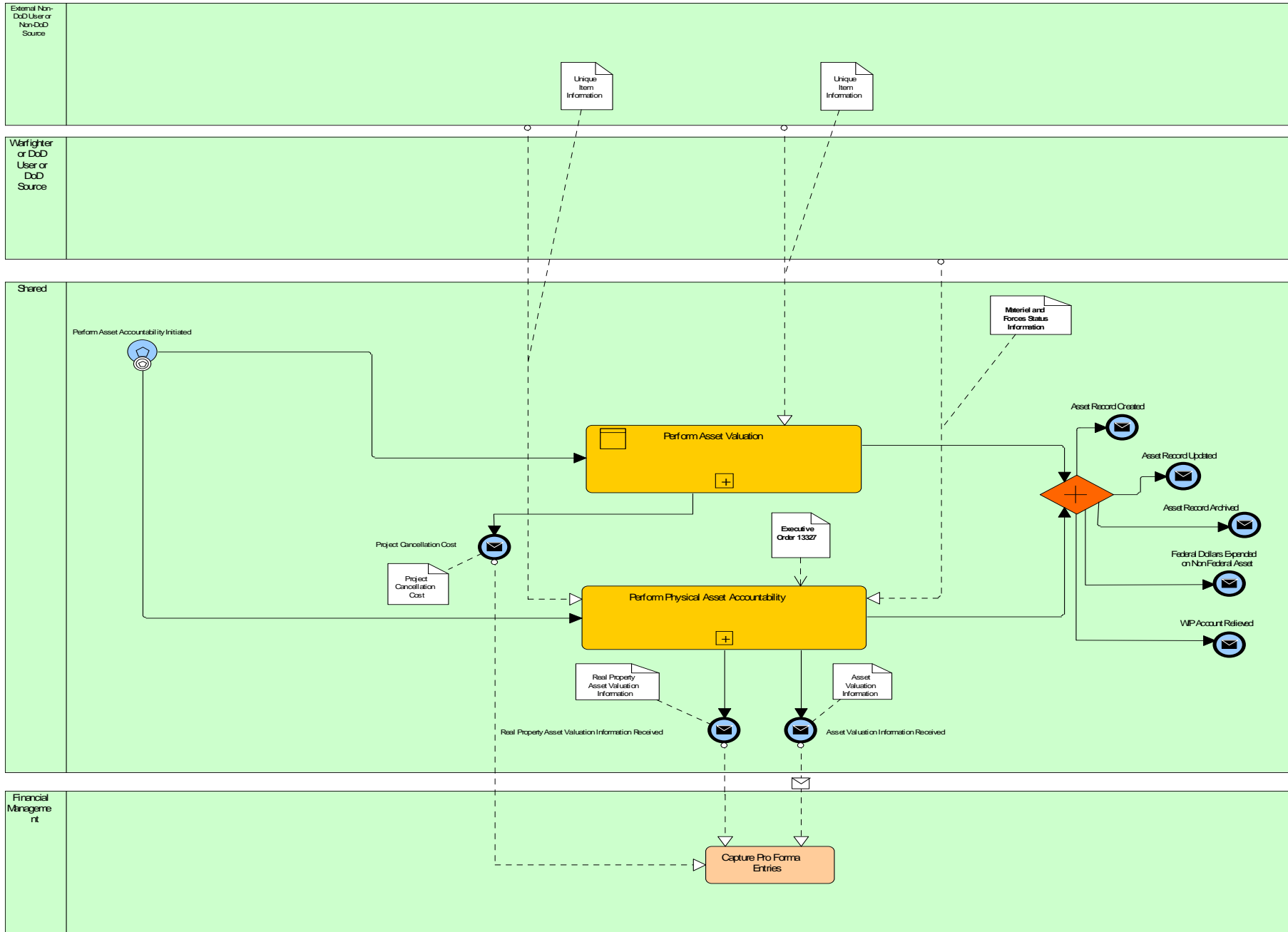

Special No Database or NewSQL Store

Shared

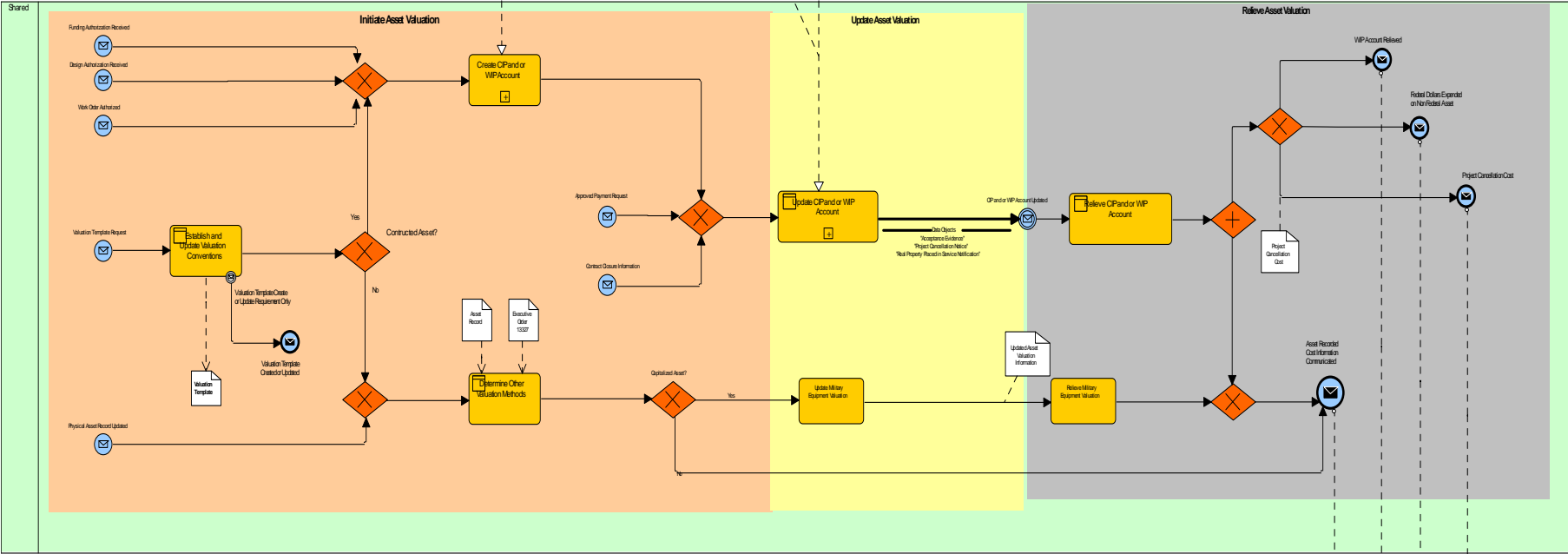

Financial Management

Weapon System Lifecycle Management

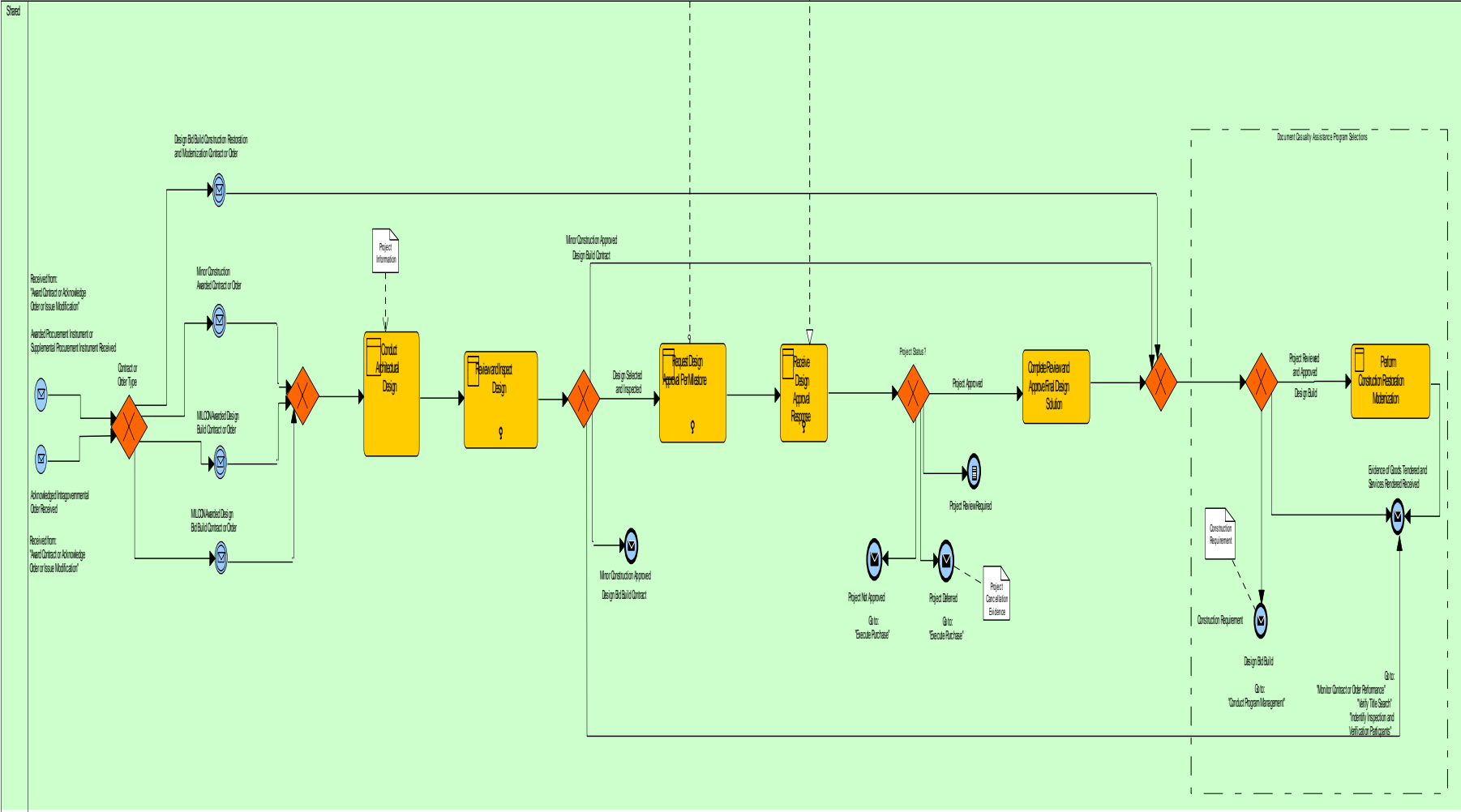
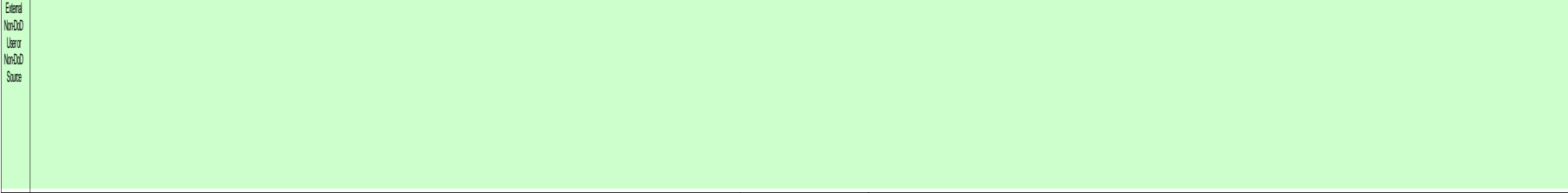

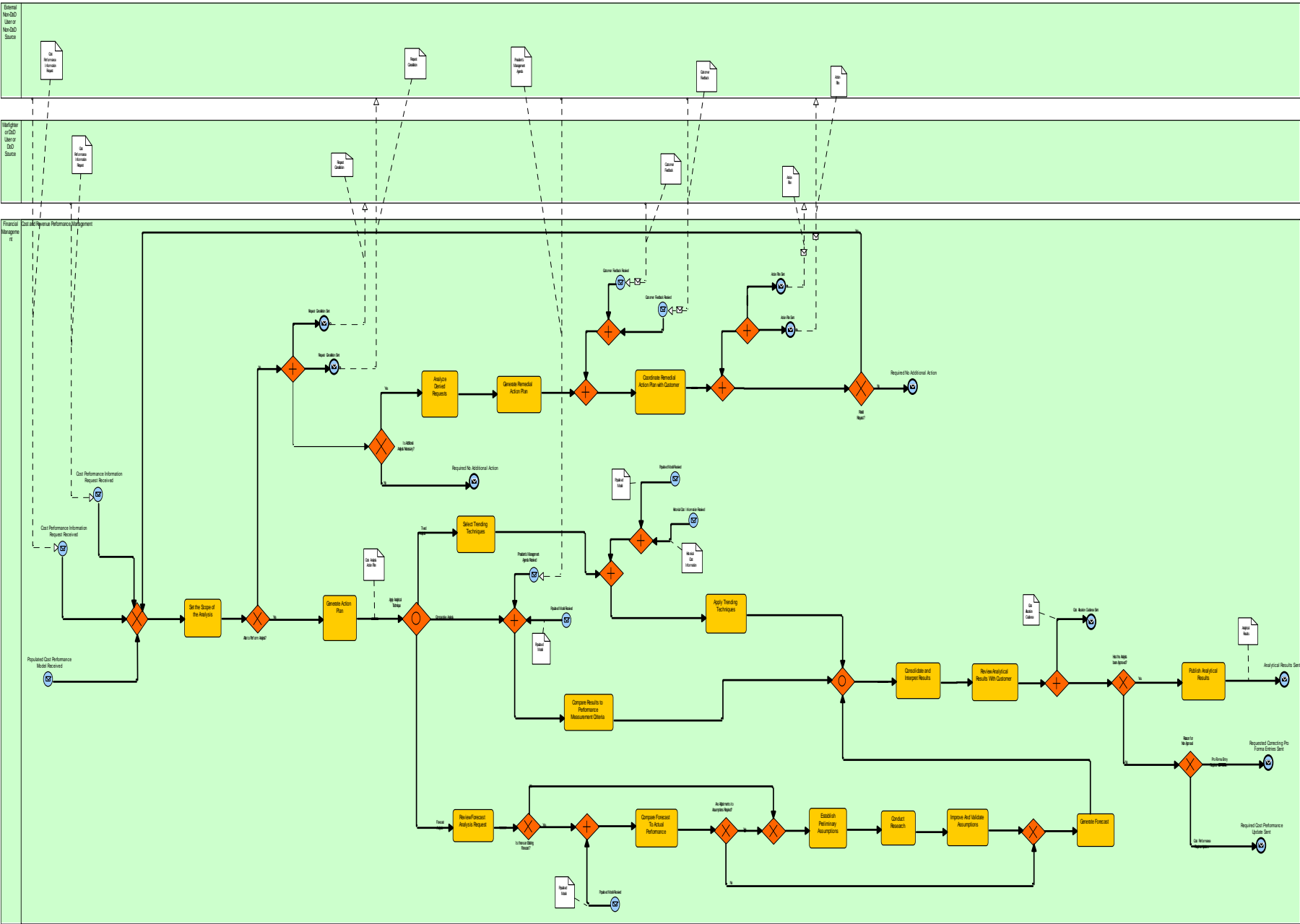

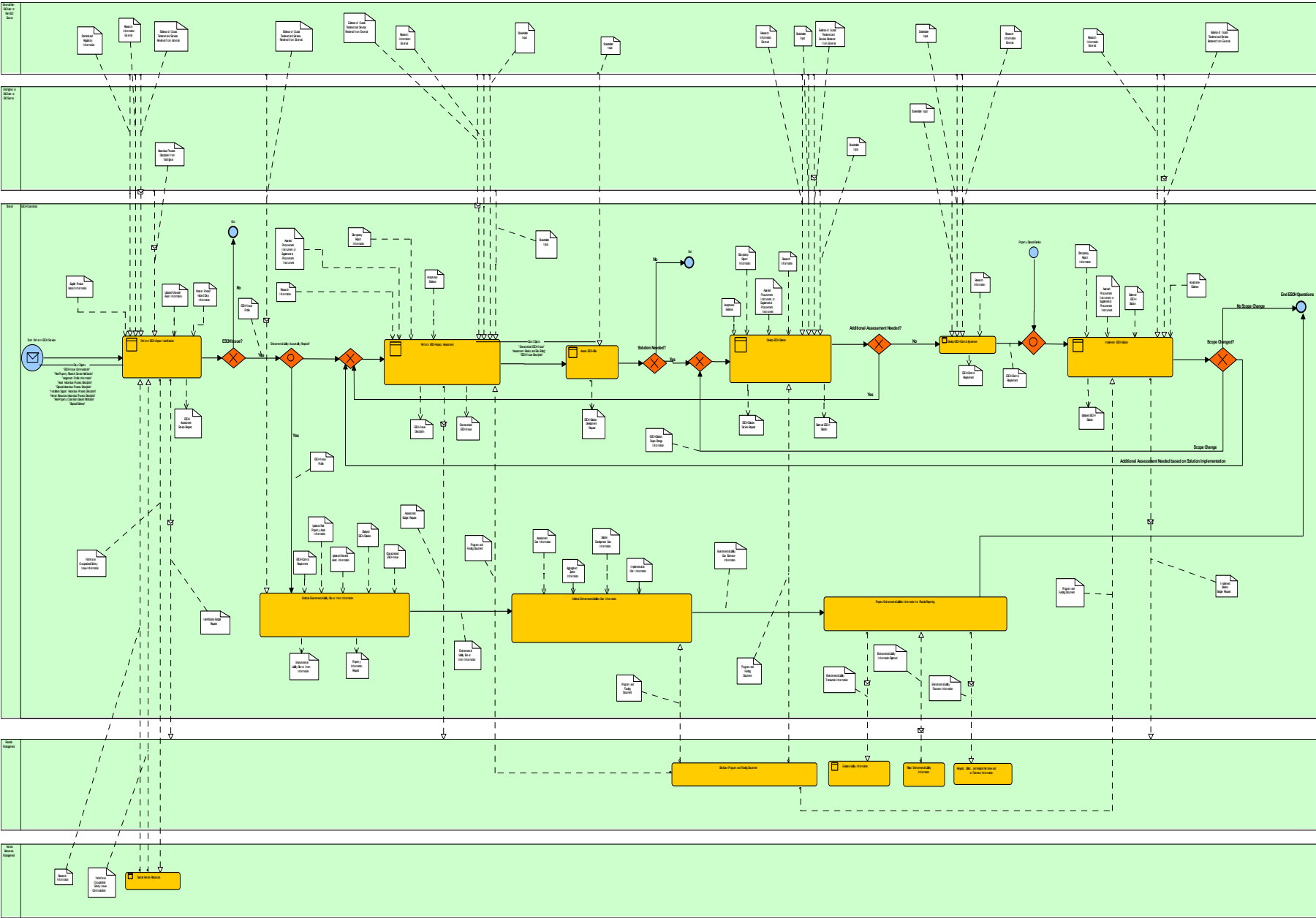

Shared

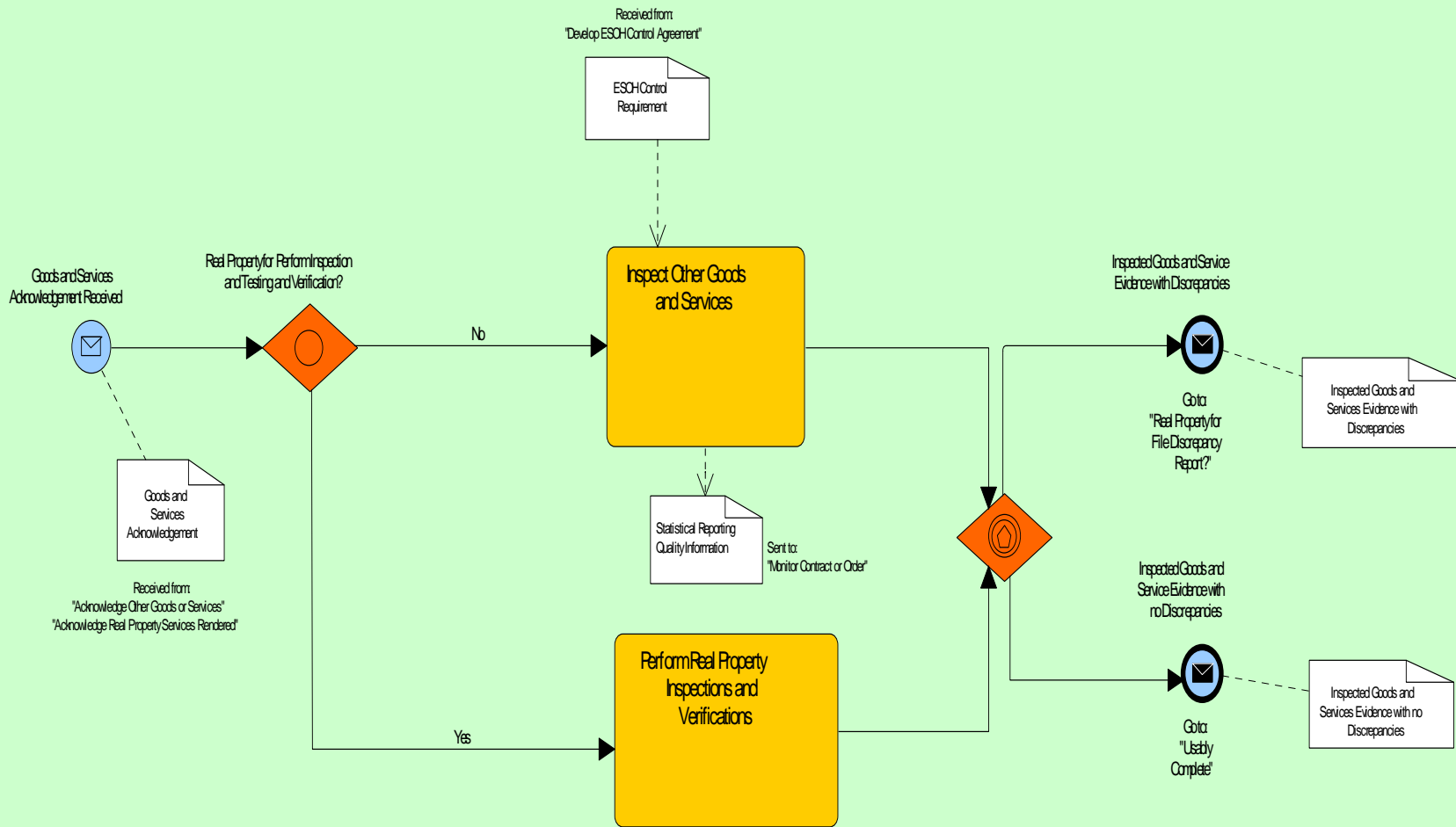

SDLC
 Backlog

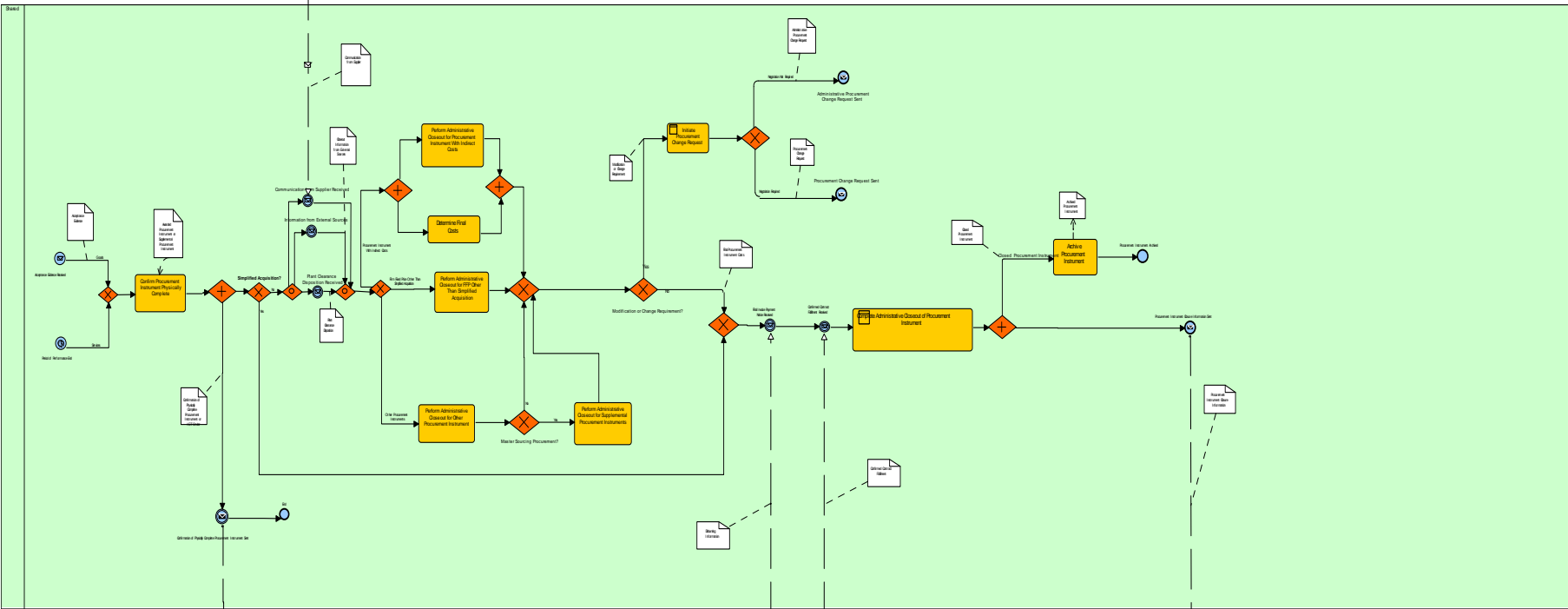

Financial Management

This is a temporary add to hold Intraprocedural (IGI) Order objects for BEA9.0. The objects were removed from PFP and will be placed in other EZE's (e.g. CIO) in a future release.

Where in CIO do these belong?

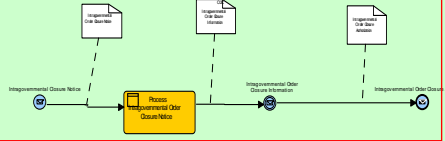

Is this accounted for in Manage Receivables?

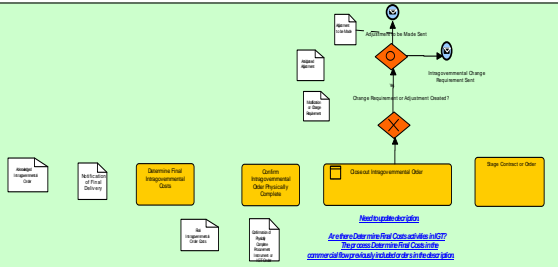
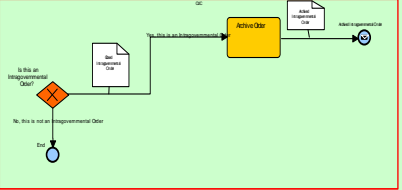

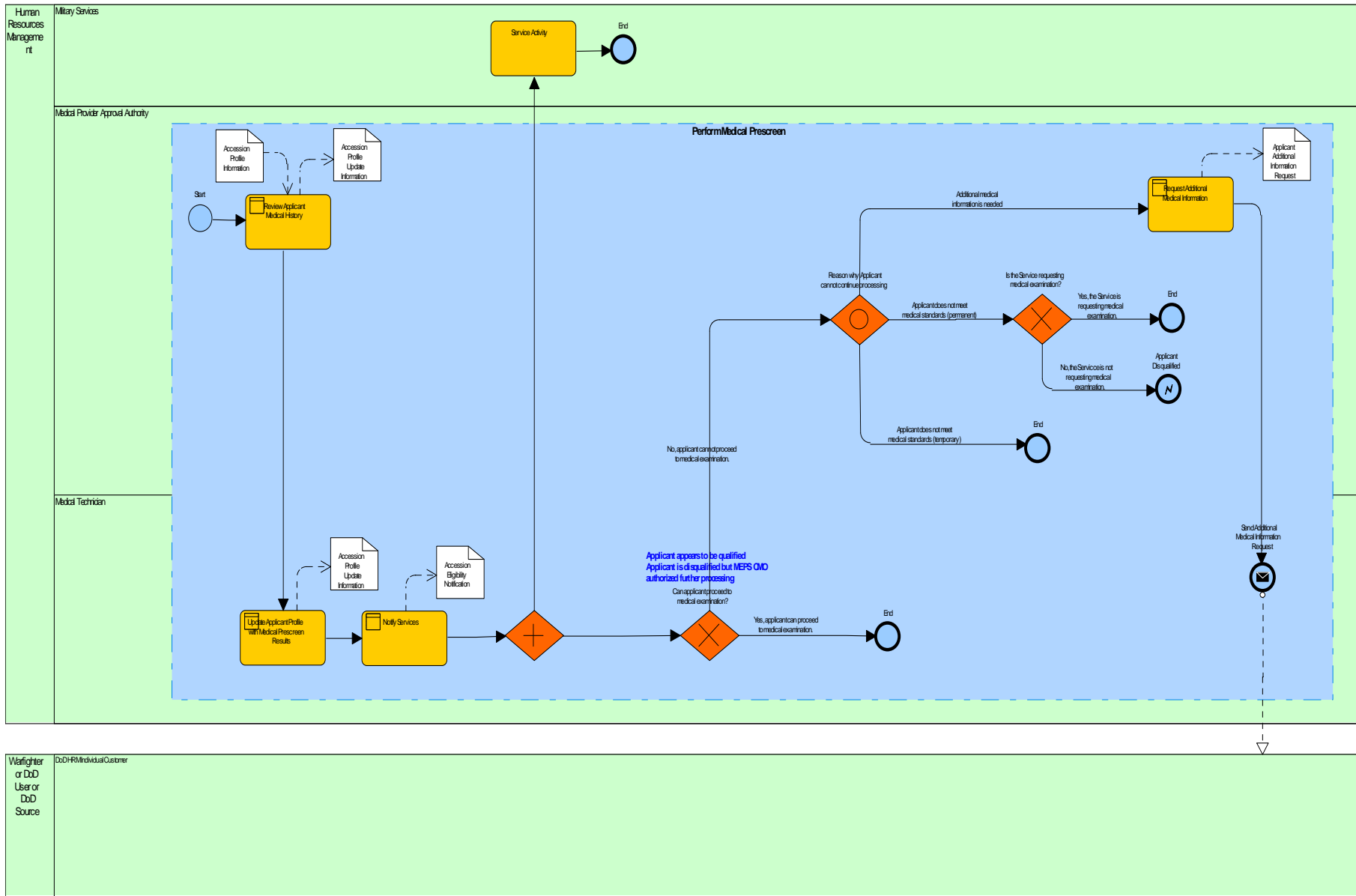

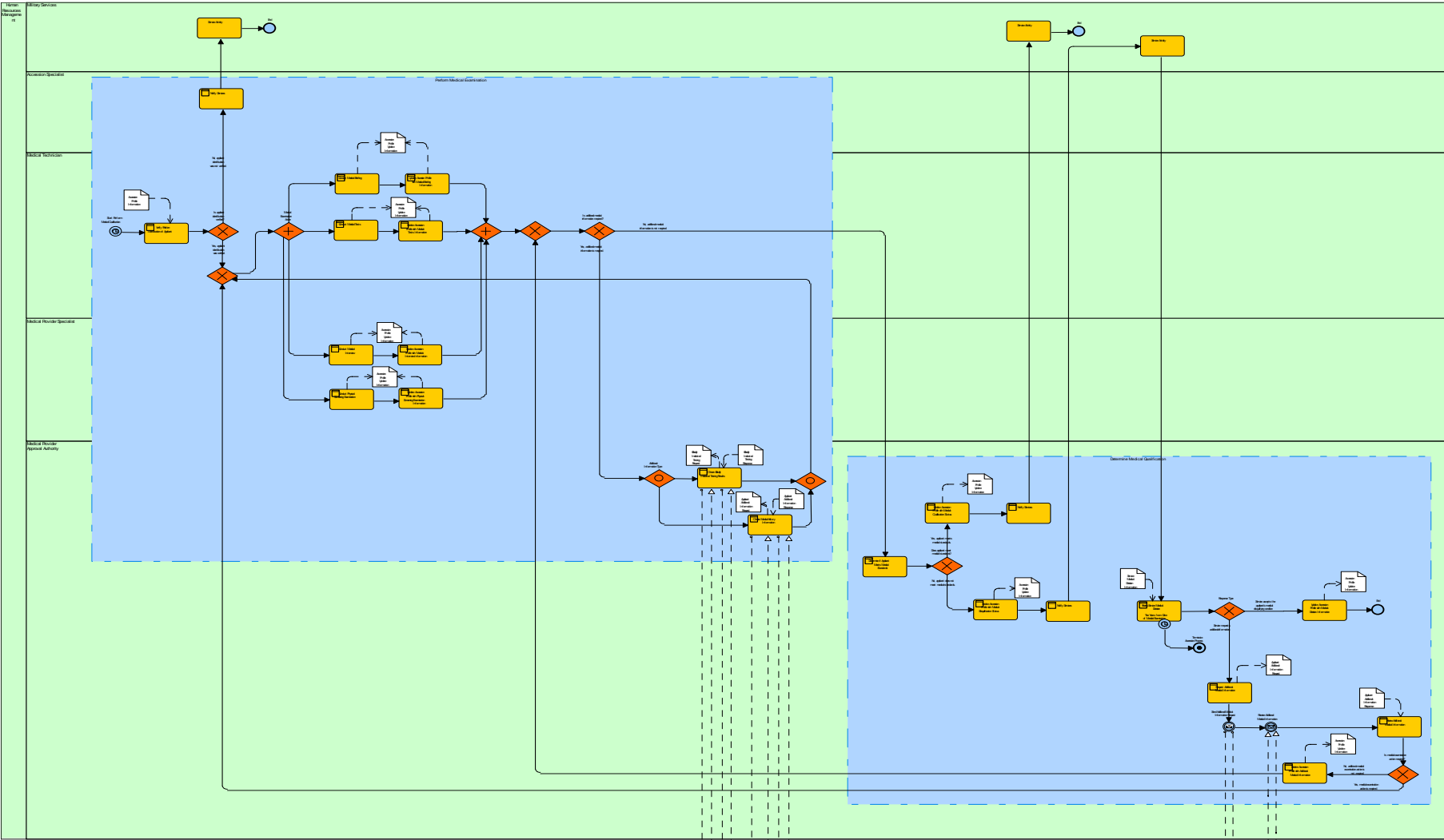

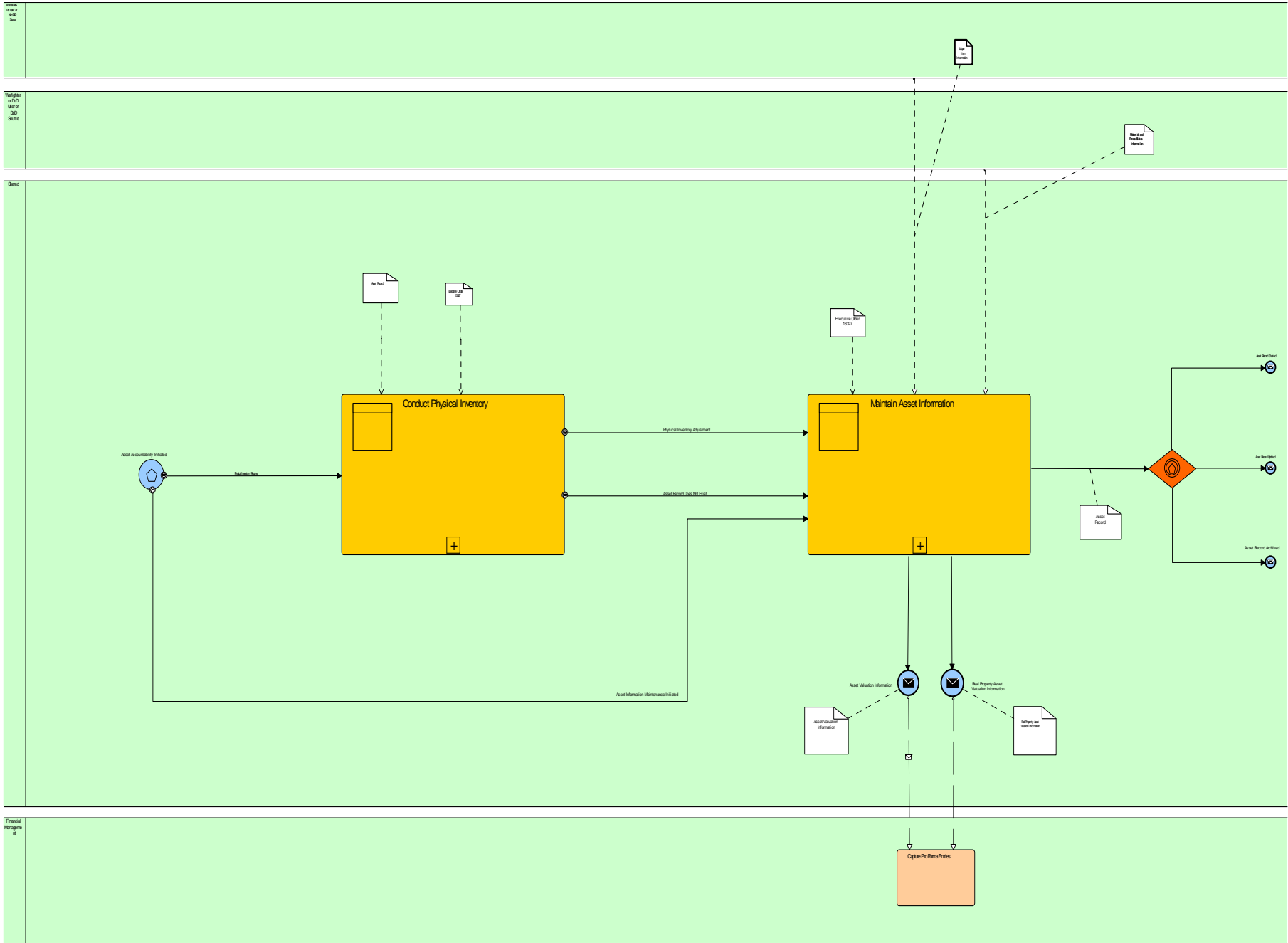

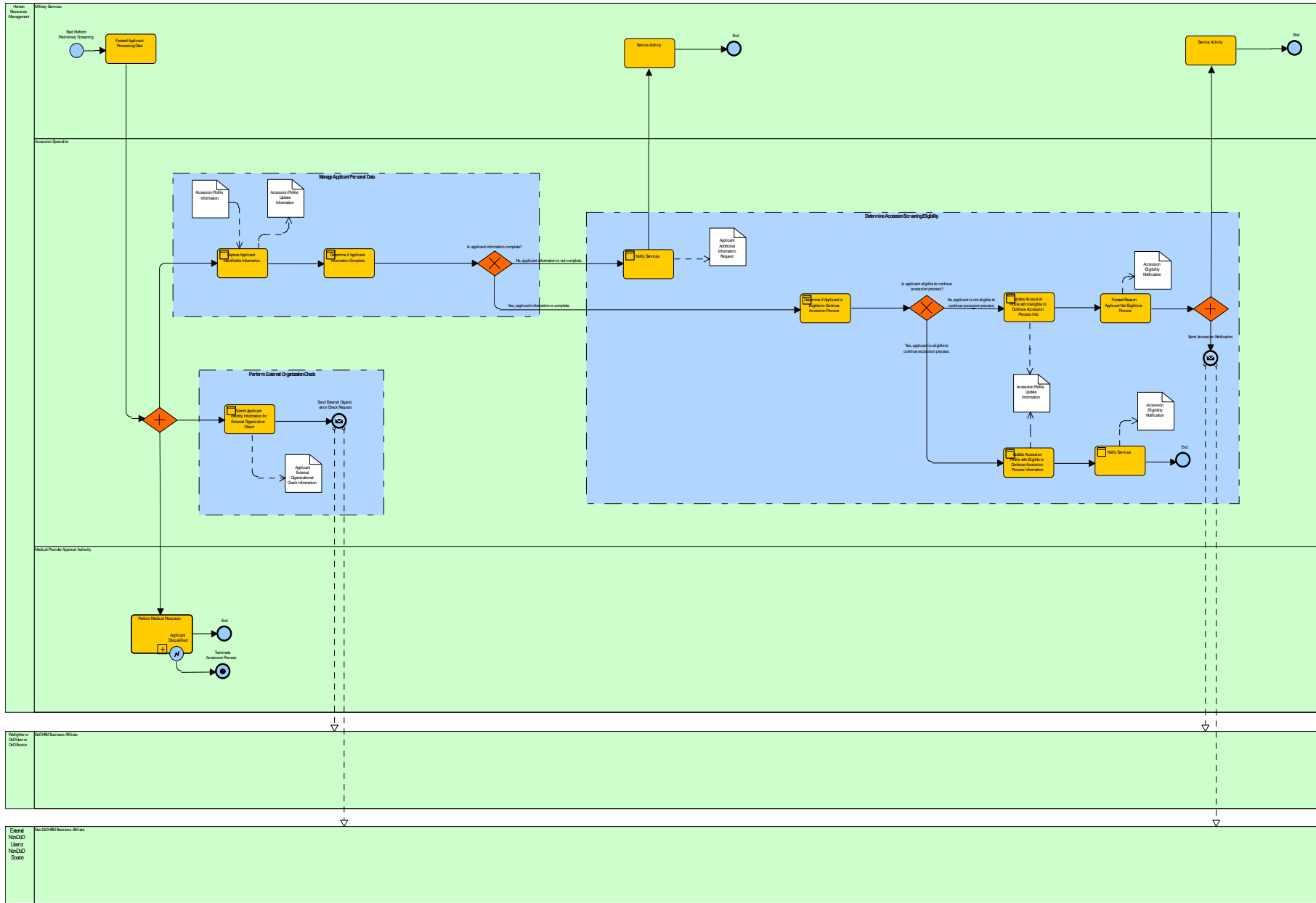

1.3 Reform Program (DRG Business Process)
 System Architect
 Wednesday, February 22, 2012 2:49 PM

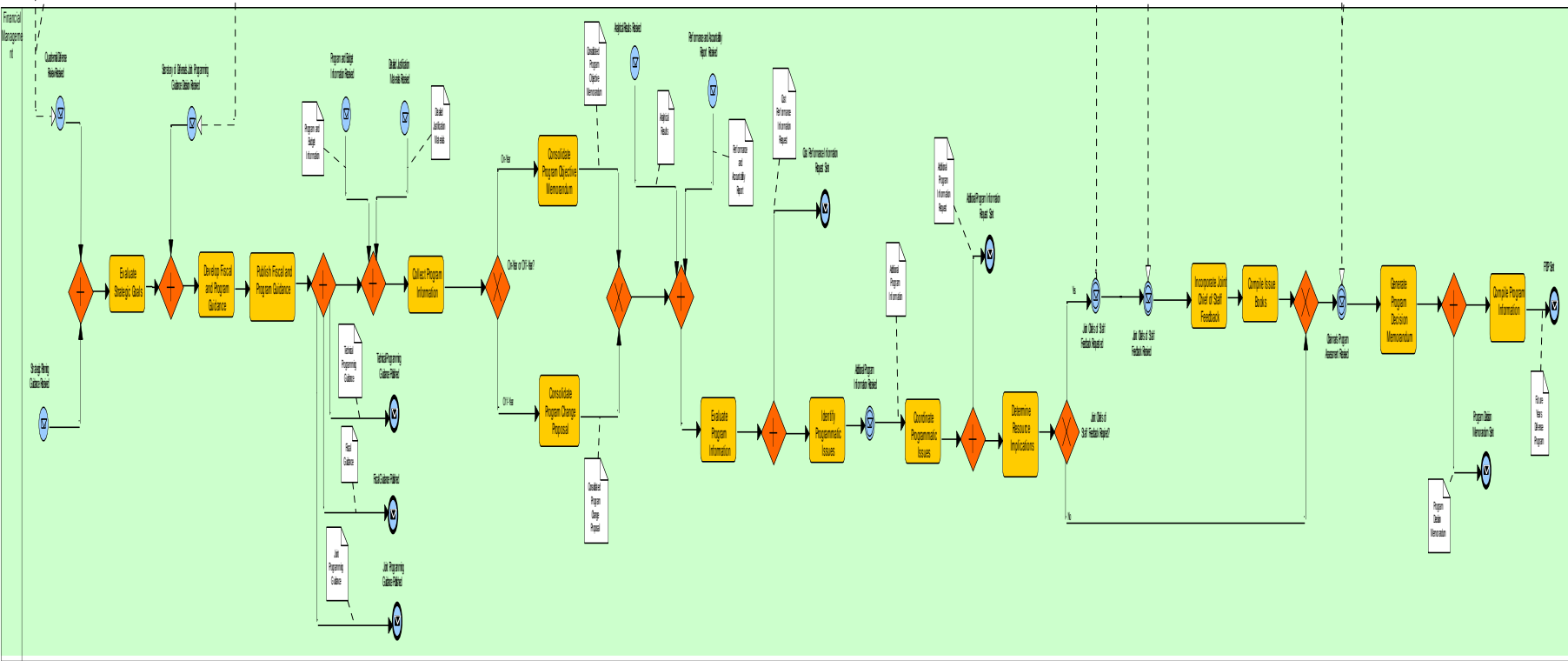
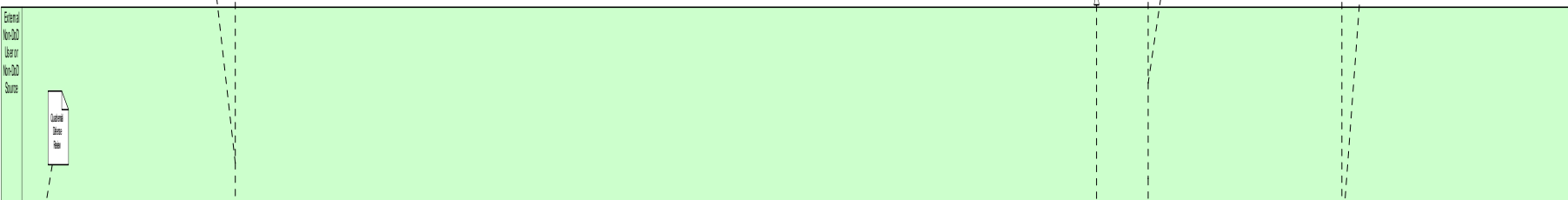
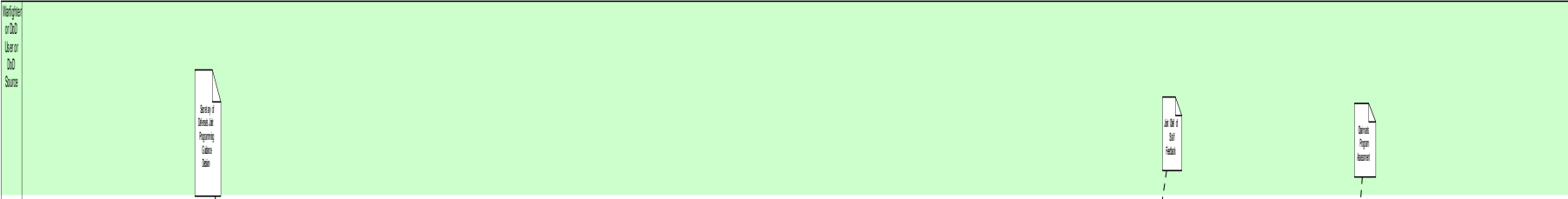

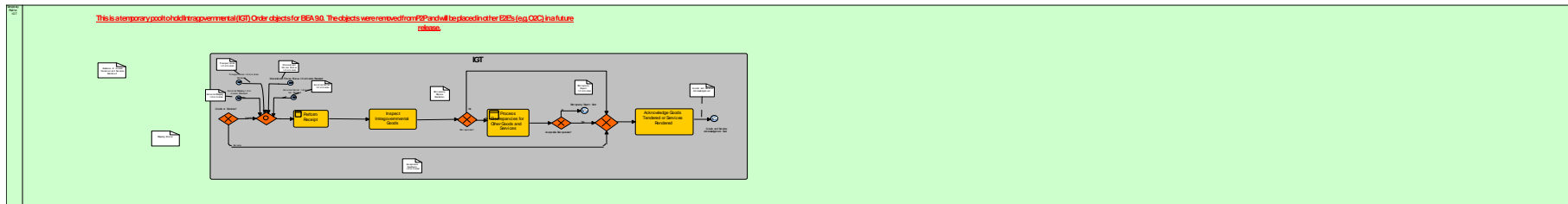
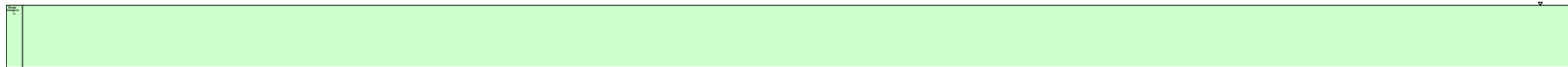
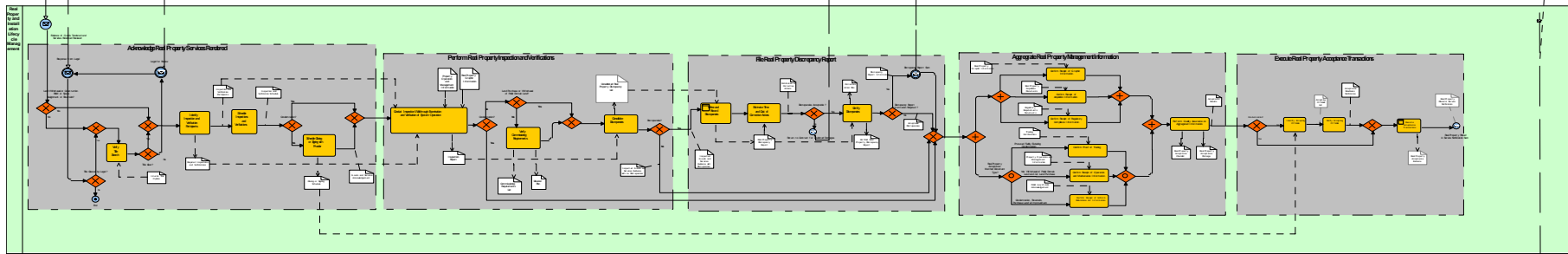
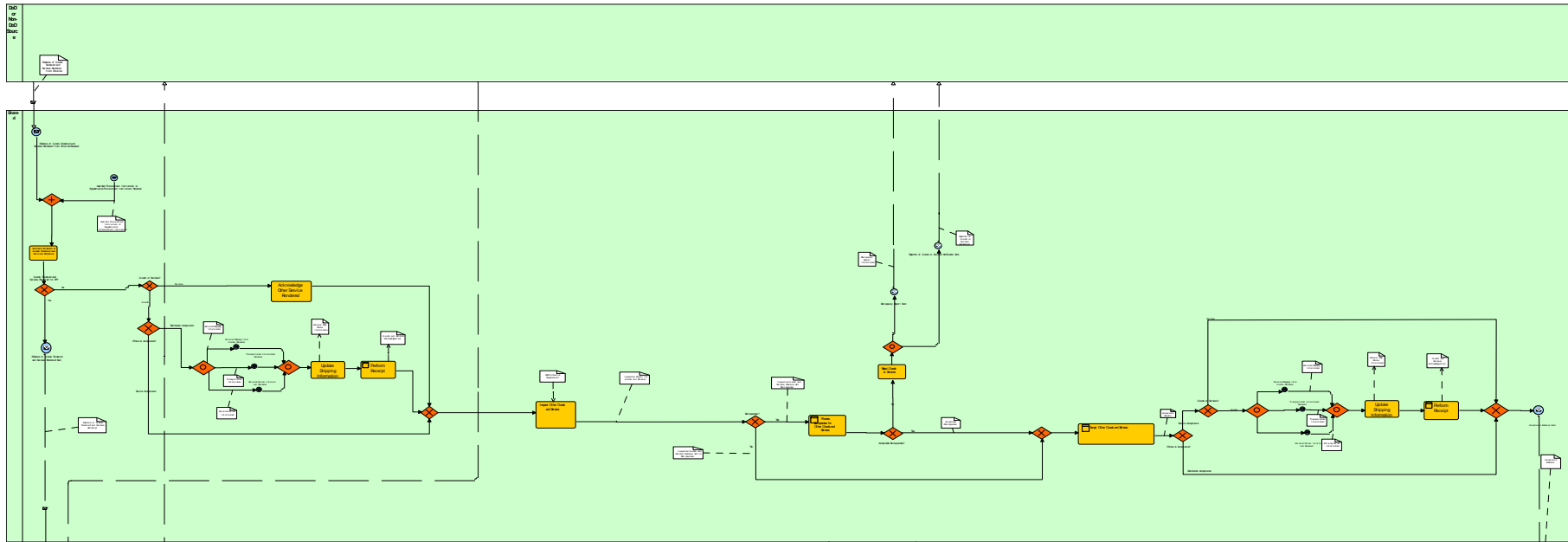

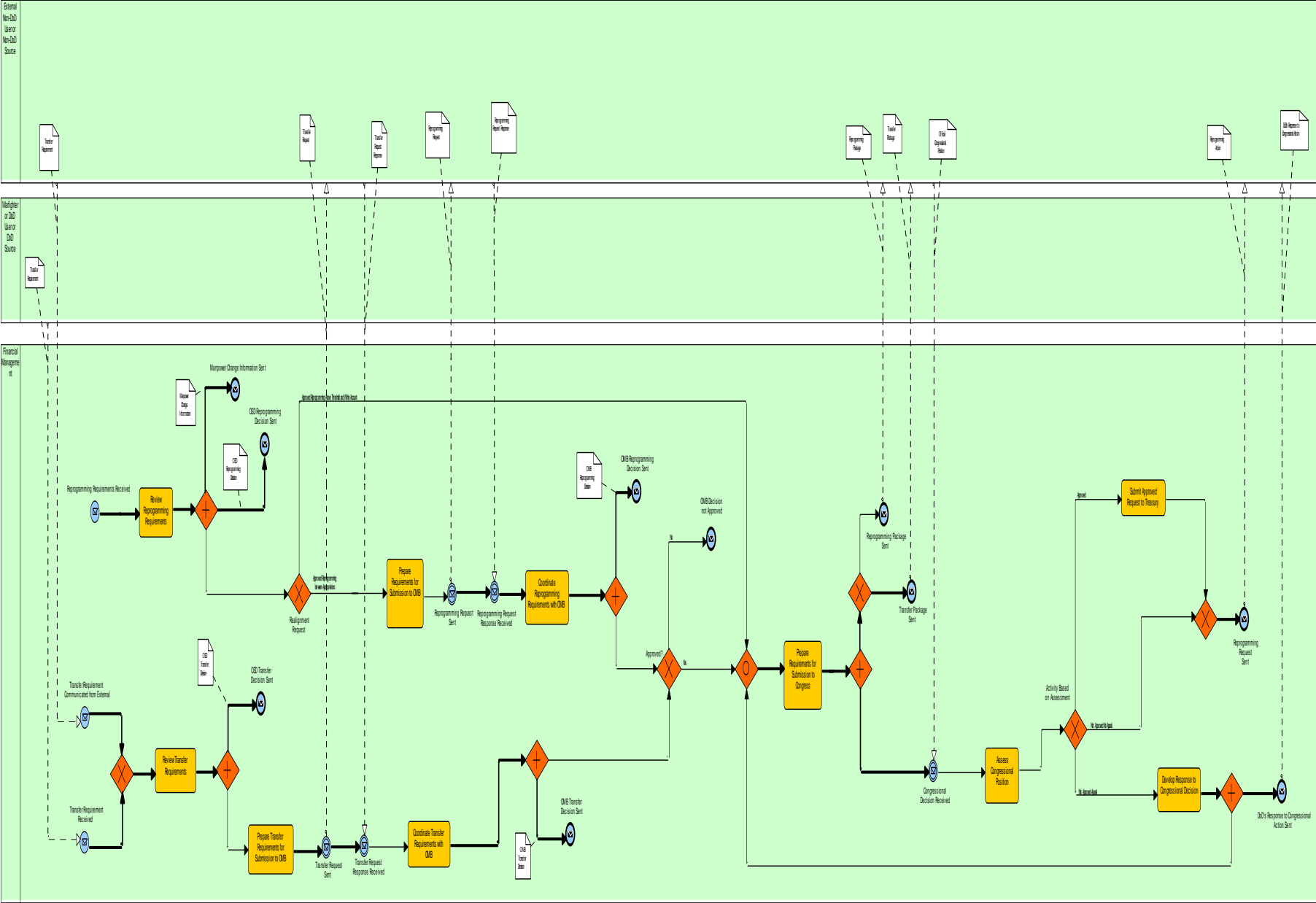

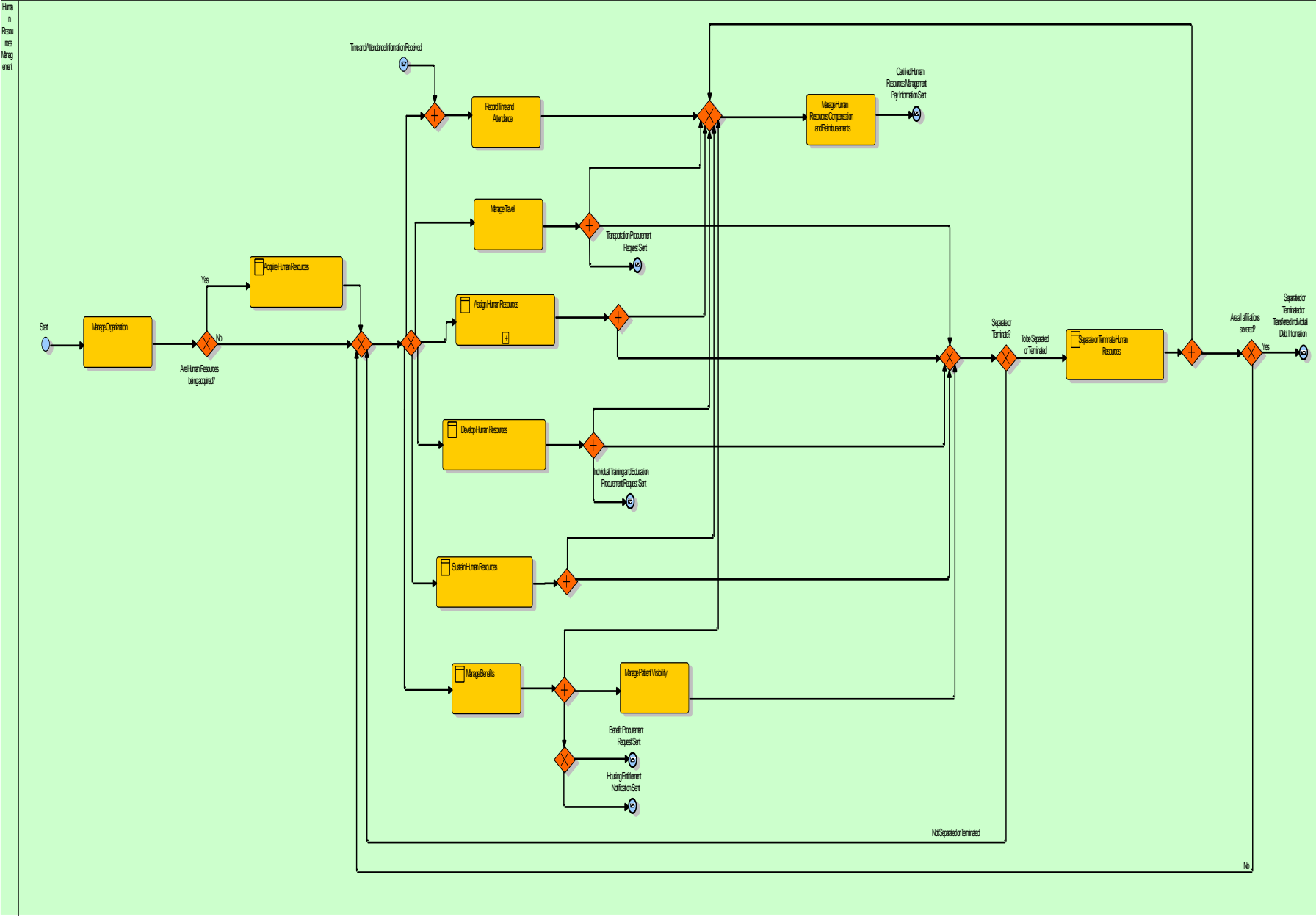

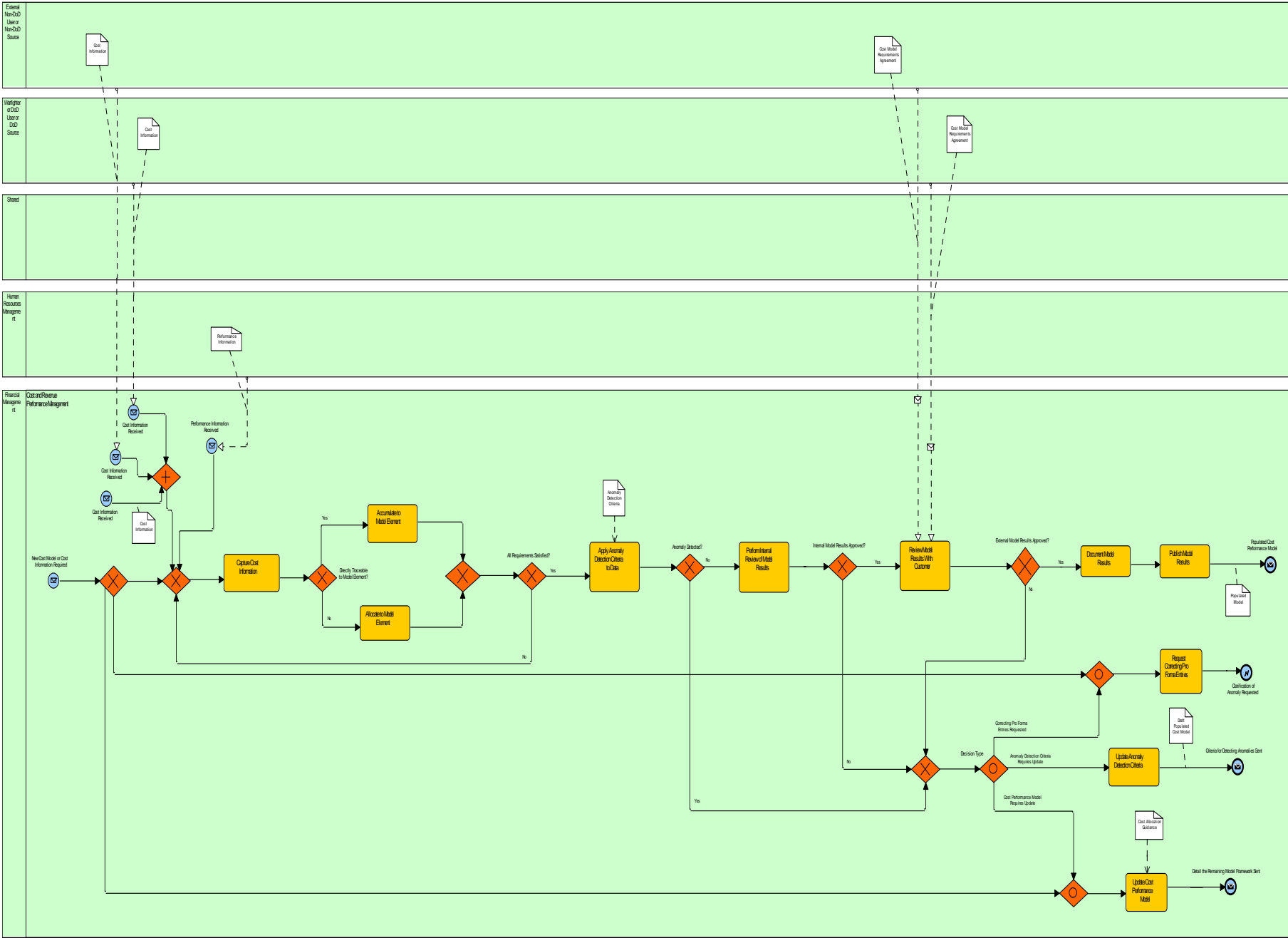

Close General Ledger (O&B) Business Process
 System Project
 Weekday, July 2, 2006 6PM

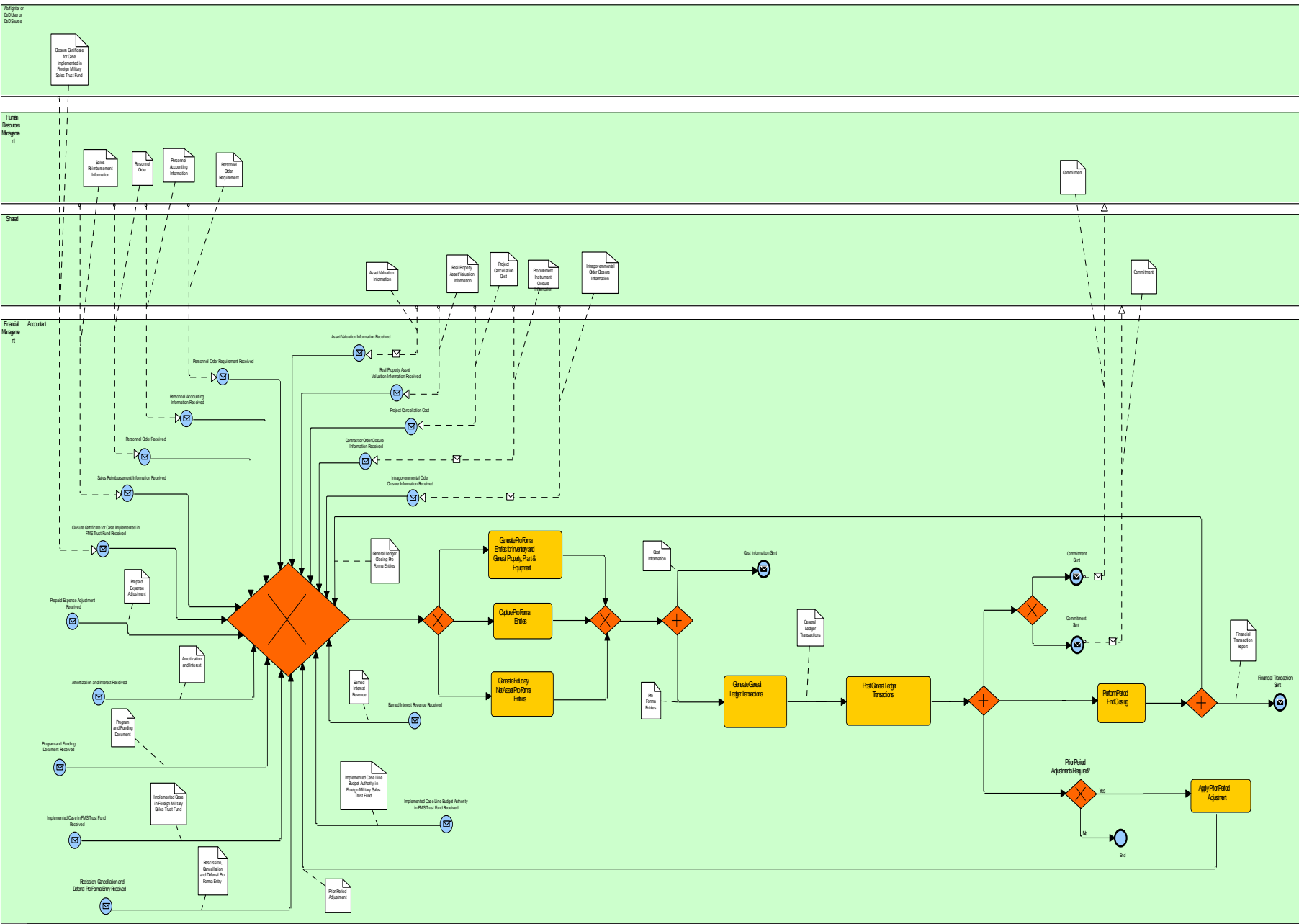

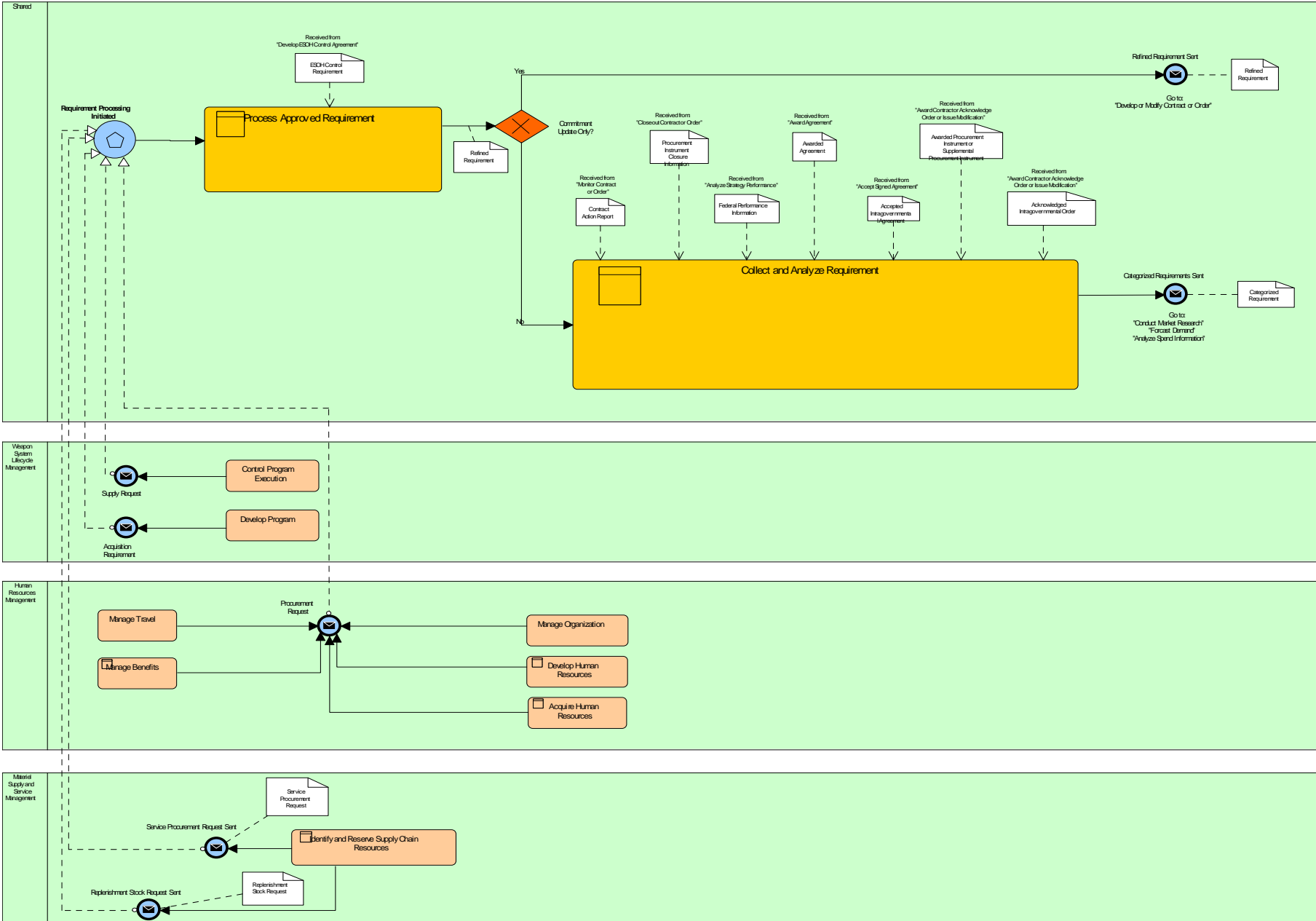

Wrighter
or DoD User
or DoD
Source

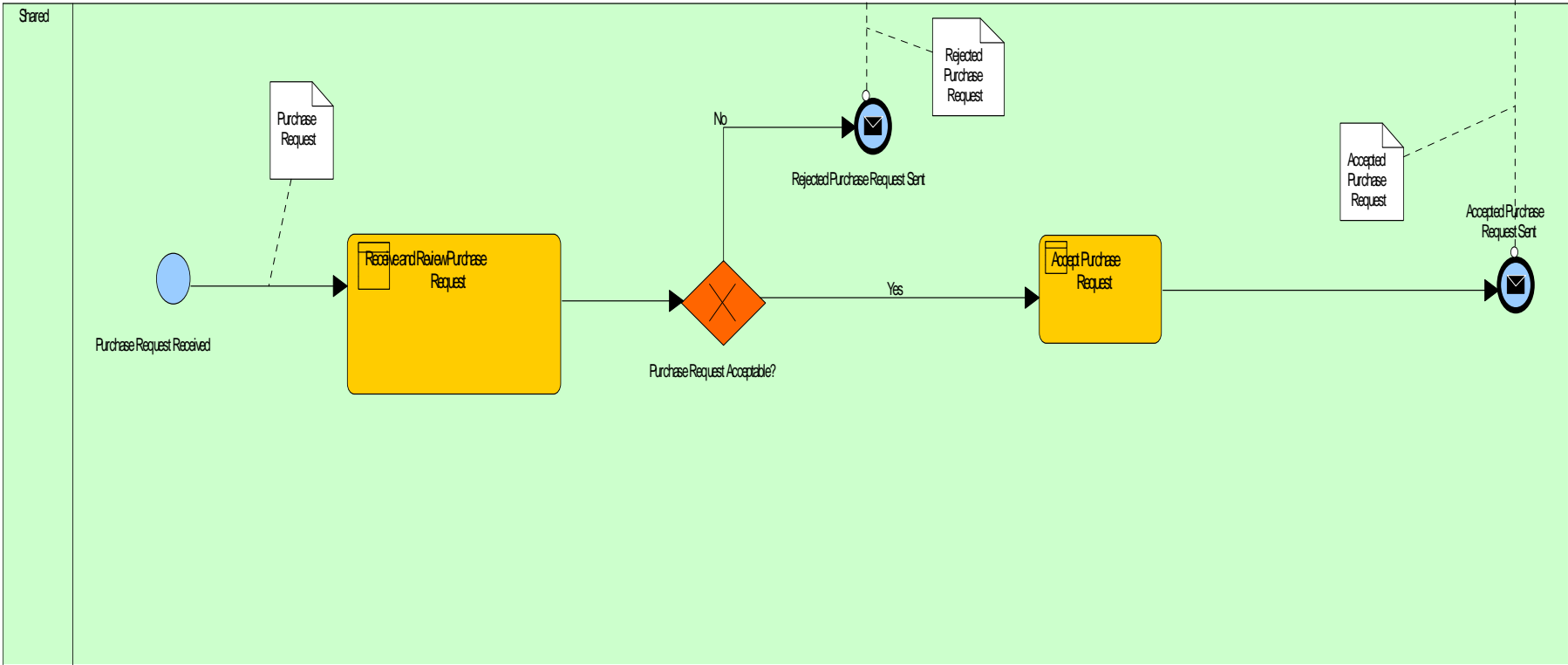

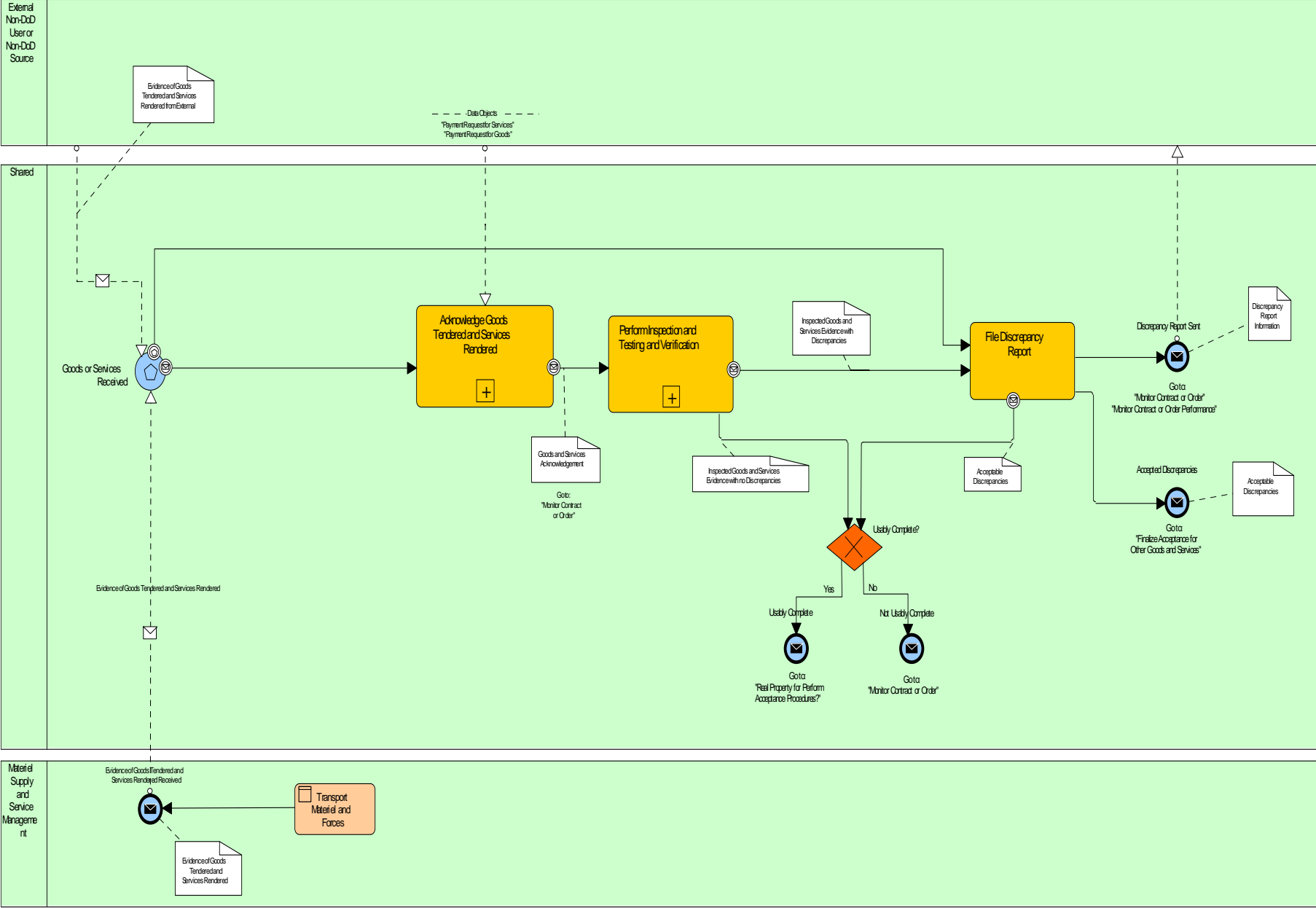

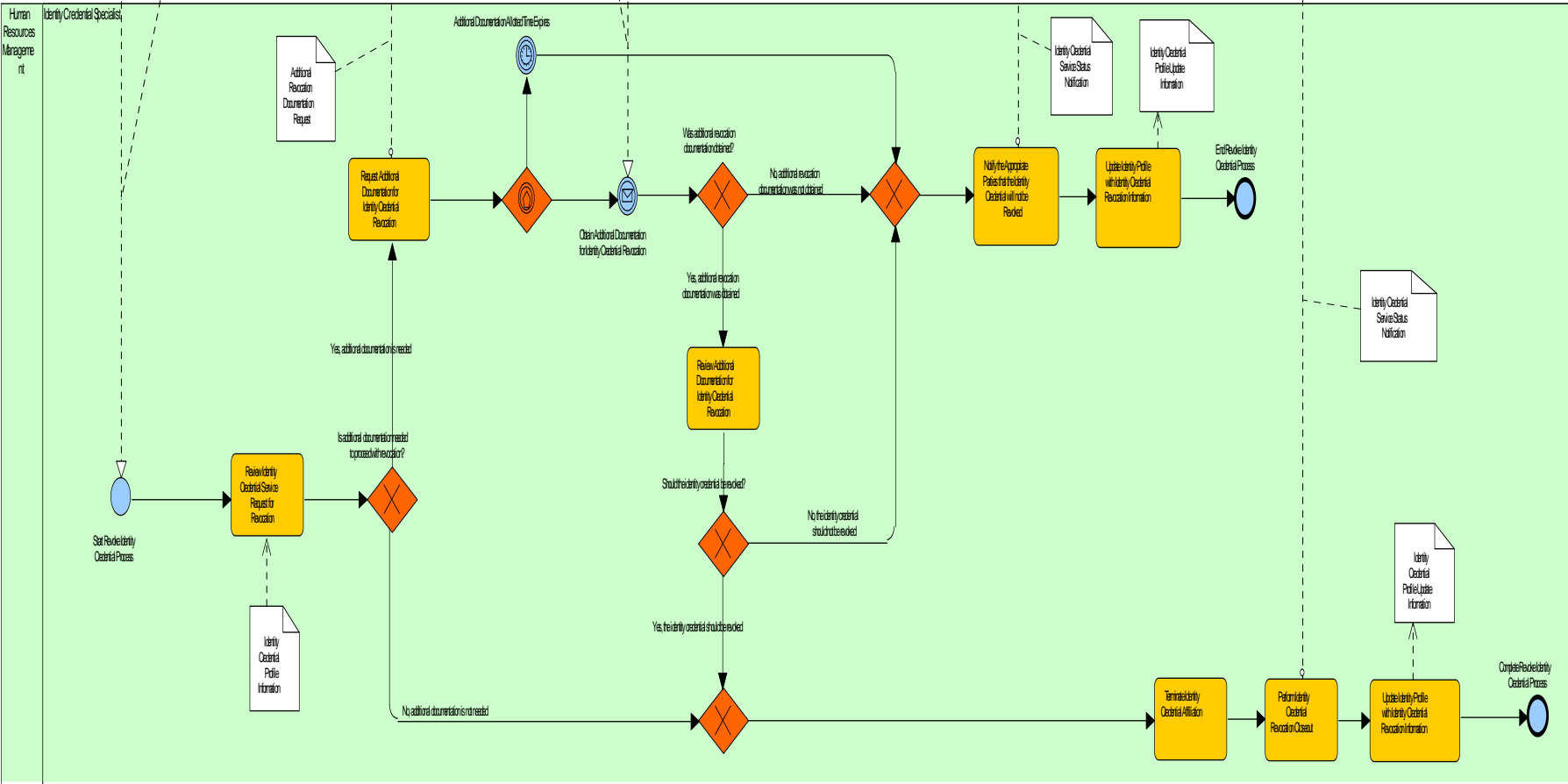

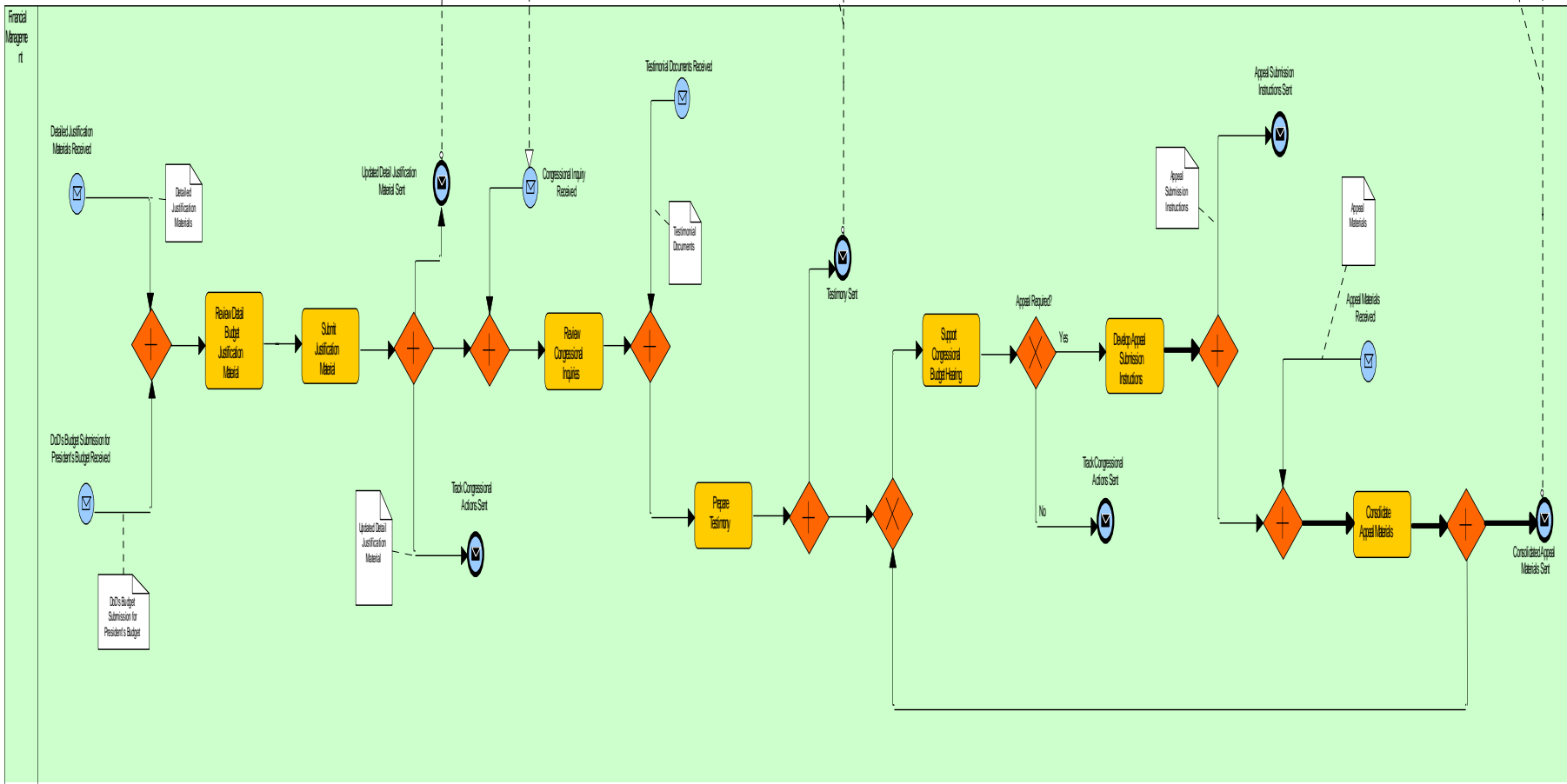
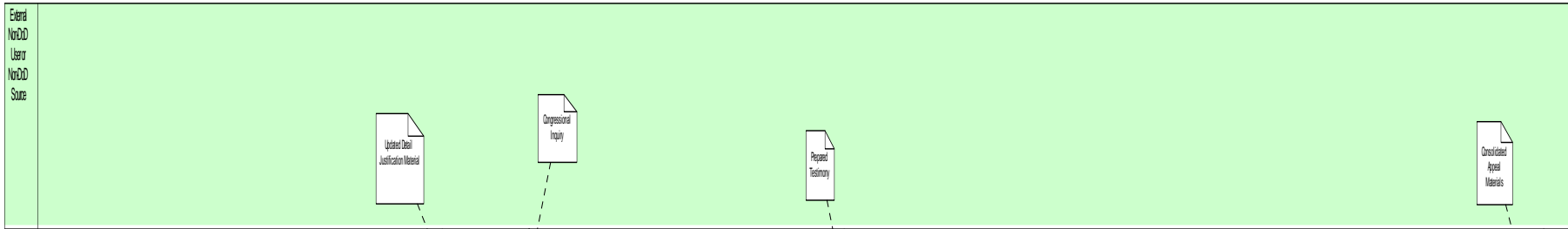

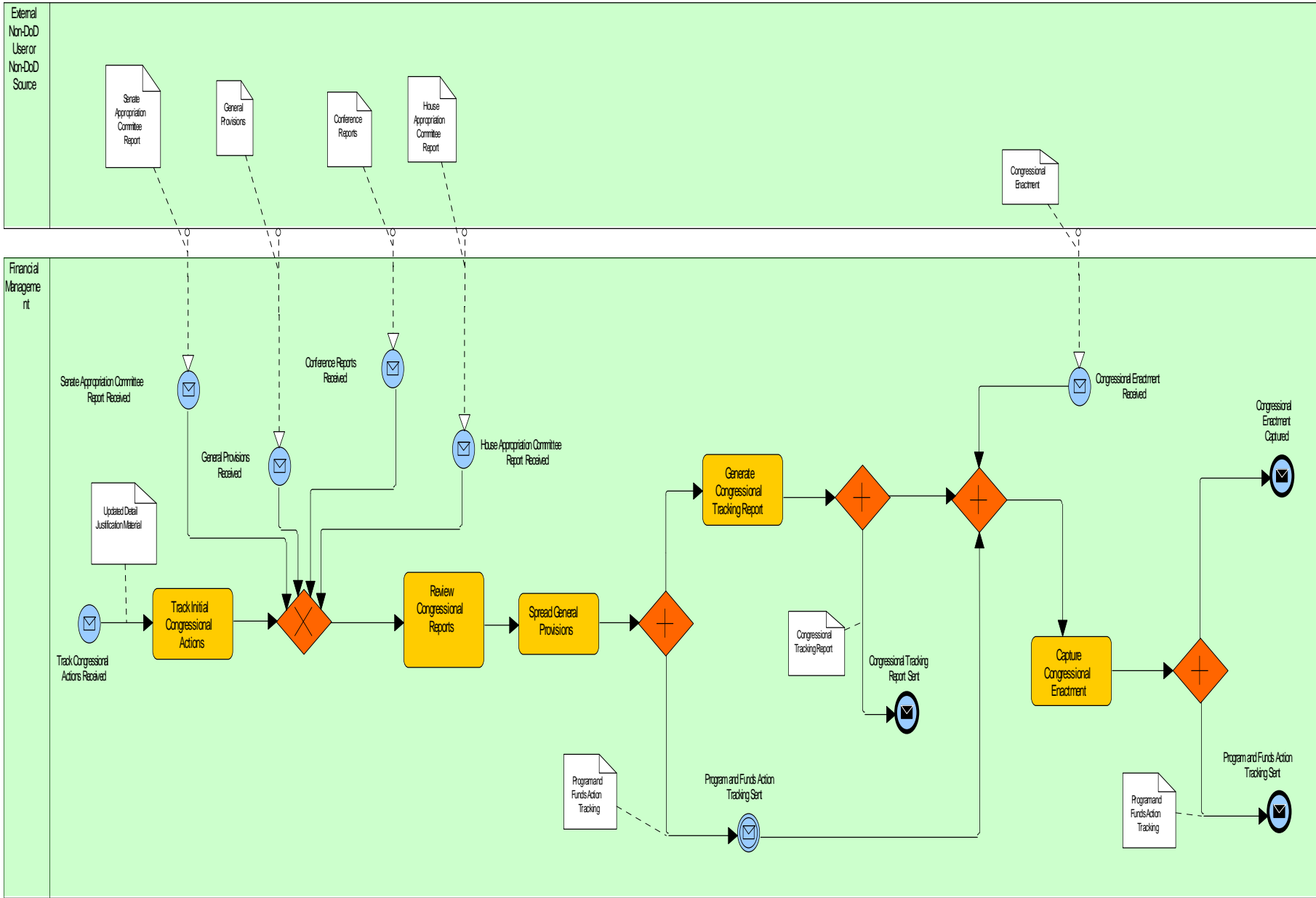

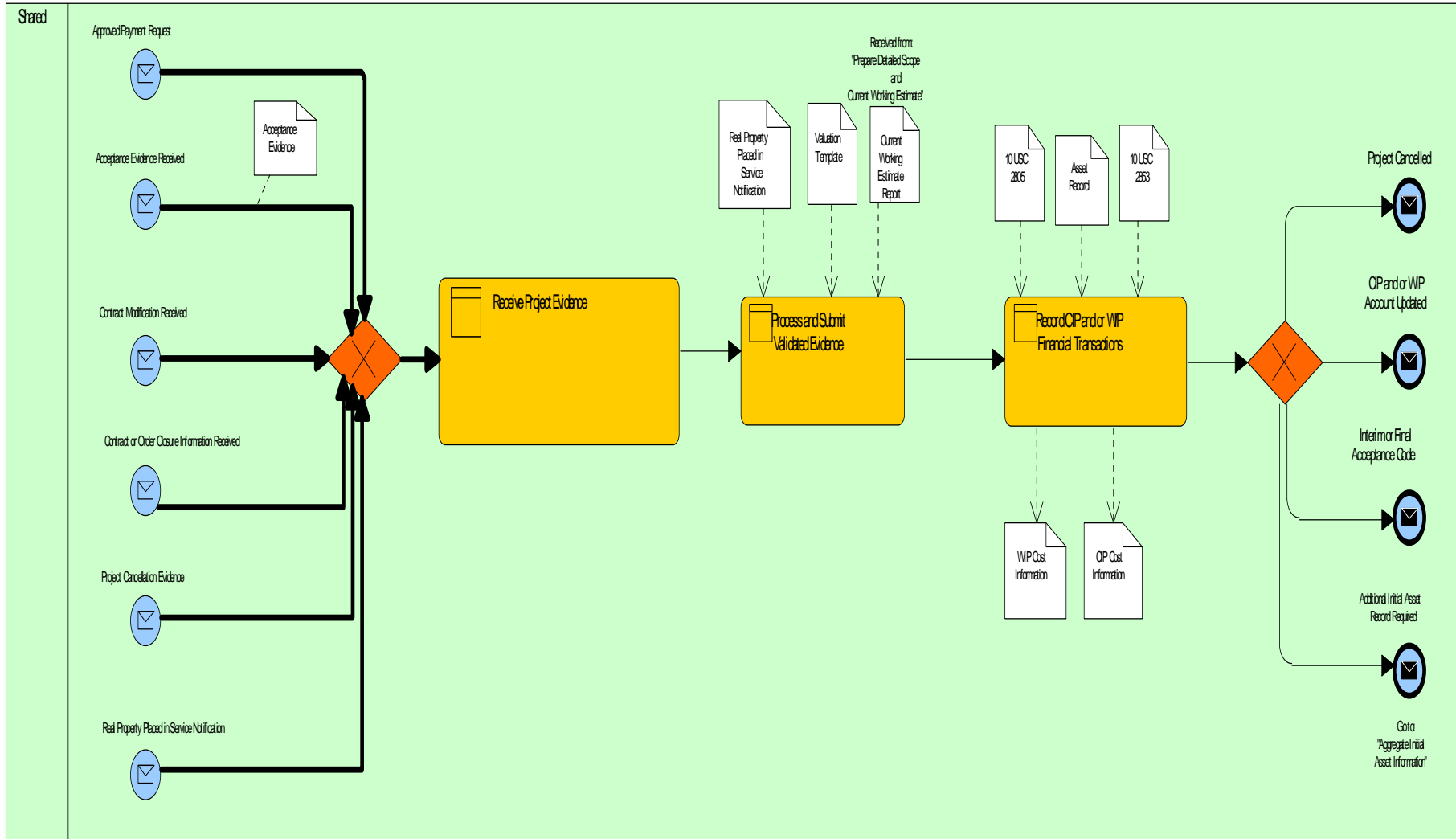

Accounting Classification Structure Composition

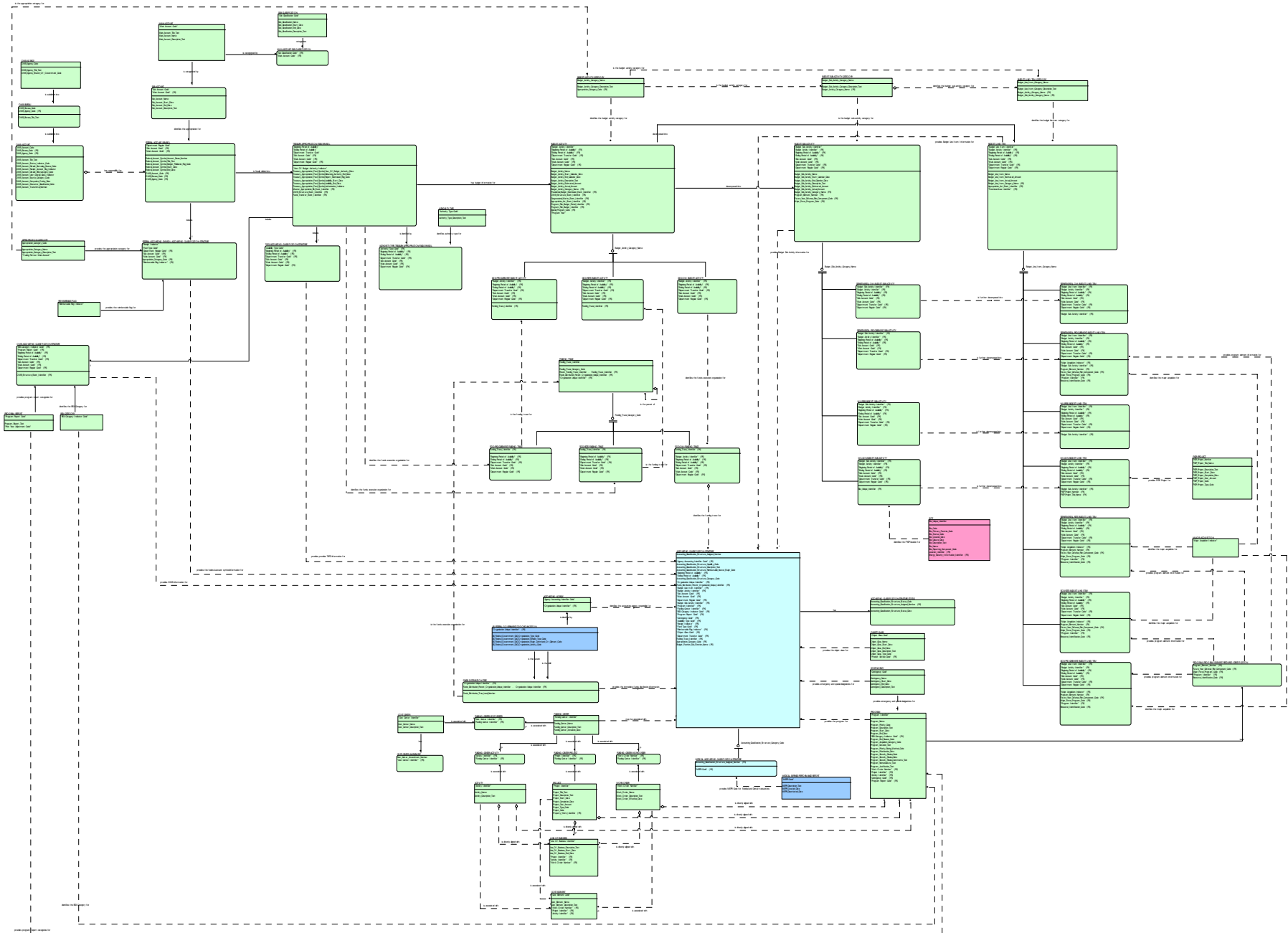

Accounting Transaction

Accounting Transaction
The Accounting Transaction is the basic unit of accounting. It is a record of a business event that affects the accounting equation. The Accounting Transaction is recorded in the Accounting Transaction Log.

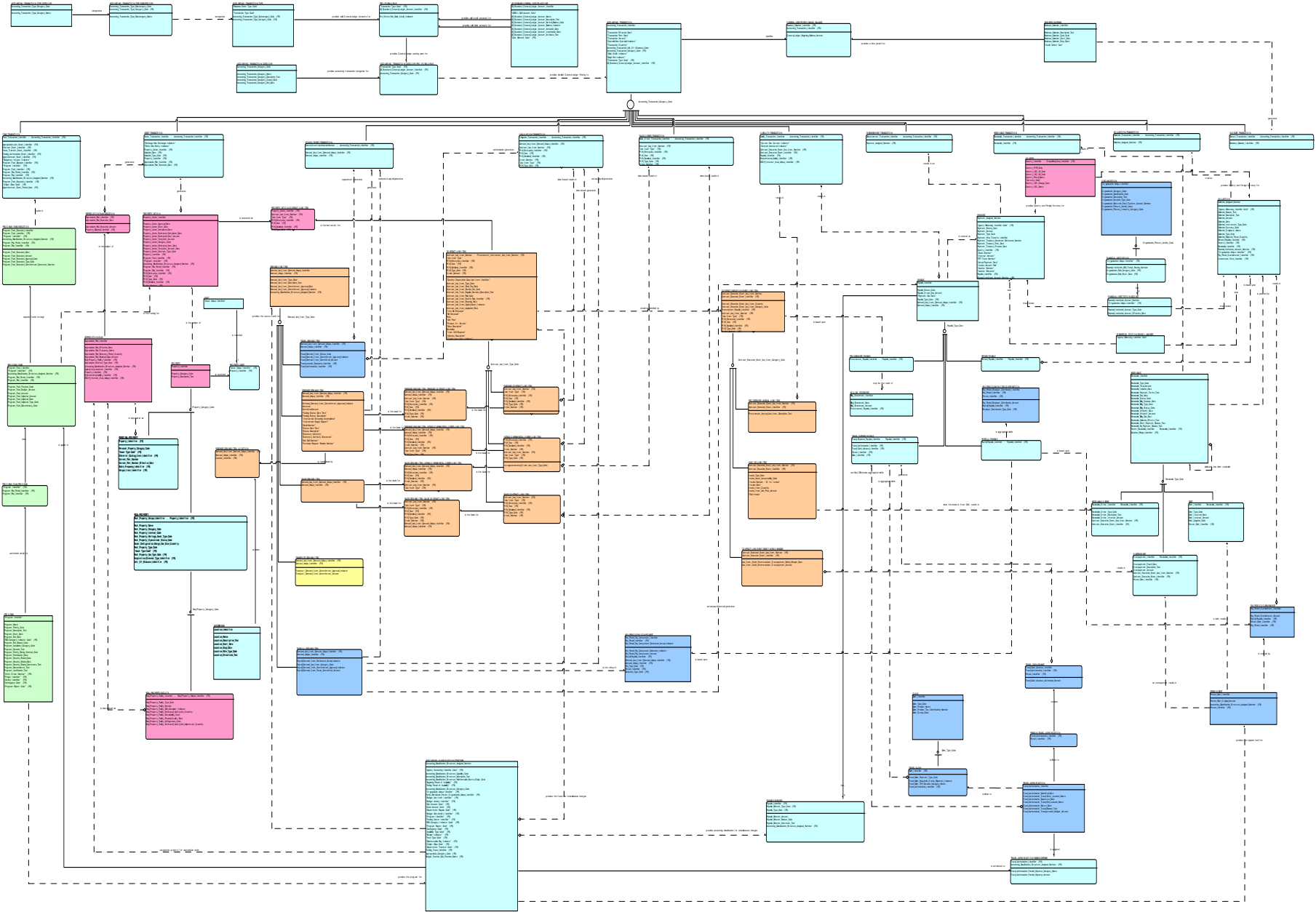

Accounts Receivable Principal Balance (CV7 Logical Data Model Subject Area)
 System Object
 Min Nov 20, 2010 14:50
 Comment
 This is the receivable principal balance used to establish the initial amount of the accounts receivable for specific customer.

Accounts Receivable Principal Balance

Accounts Receivable Principal Balance Debit

- Action Code*
- External Employment Debt ID*
- Individual or Business*
- Type of Public Debt*
- Data Type*
- Administrative Debt Classification*
- Consumer or Commercial*
- Transaction Effective Date*
- Debit Line Date*
- Transaction Amount*
- Beneficiary Name*
- Terms
- Previous Document Identifier*
- Contract Identifier*
- Accounting Classification Reference Number (ACRN)*
- Contract Line Item (CLIN)*
- Contract Sub Line Item (SLIN)*
- Event Line Item (ELIN)*
- FCC/Office who handles the debt account*
- Reason Status Code*
- Appr. Limitation Subhead*
- Department Regular Code*
- Department Transfer Code*
- Main Account Code*
- Sub Account Code*
- Period of Availability Fiscal Year Date*
- Reimbursable Flag Indicator*
- Budget Activity Identifier*
- Budget Sub Activity Identifier*
- Budget Line Identifier*
- Foreign Military Sales Customer Code*
- Foreign Military Sales Case Identifier*
- Foreign Military Sales Case Line Item Identifier*
- Foreign Non-Federal Indicator Code*
- Trading Partner Indicator Code*
- Business Partner Number*
- Agency Accounting Identifier Code*
- Funding Career Identifier*
- Cost Center Identifier*
- Project Identifier*
- Activity Identifier*
- Work Order Number*
- Transaction Quantity*
- UNIT_OF_MEASURE_CODE

Accounts Receivable Principal Balance Debit - Contact Info

- Action Code*
- External Employment Debt ID*
- External Employment Debt ID*
- Debtor TIN*
- Debtor TIN Type*
- Contact Type*
- Contact Title*
- Contact Free Form Name*
- Contact Primary Name*
- Contact Address 1*
- Contact Address 2*
- Contact City*
- Contact State*
- Contact Zip Code*
- Contact Country Code*
- Contact Primary Address*
- Contact Phone Type*
- Contact Phone*
- Contact Phone Ext*
- Contact Primary Phone*
- Contact Email Address*
- Contact Primary Email Address*

Accounts Receivable Principal Balance Debit - Property Info

- Action Code*
- External Employment Debt ID*
- External Employment Debt ID*
- Property Type*
- Property Desc*

Accounts Receivable Principal Balance Debit - Individual Employment

- Action Code*
- External Employment Debt ID*
- External Employment Debt ID*
- Job Title*
- Salary*
- Salary Cycle*
- Salary Gross or Net*
- Employer Name*
- Employer ID*

Accounts Receivable Principal Balance Debit - Alias Name

- Action Code*
- External Employment Debt ID*
- External Employment Debt ID*
- Debtor Alias Type*
- Debtor Alias Lessor Business Name*
- Debtor Alias First Name*
- Debtor Alias Middle*
- Debtor Alias Generation*

Accounts Receivable Principal Balance Creditor Agency Financial Trans Adjustment

- Action Code*
- Trans Sequence Number*
- External Employment Debt ID*
- External Employment Debt ID*
- Adjustment Reason Status Code*
- Financial Transaction Type*
- Trans Type*
- Transaction Date*
- SGNED Principal Amount*
- SGNED Interest Amount*
- SGNED Admin Cost Amount*
- SGNED Penalty Amount*
- SGNED Trans Amt*
- Agency Match Original Trans ID*
- Transaction Amount of Original Debt*
- Contract Identifier*
- Accounting Classification Reference Number (ACRN)*
- Contract Line Item (CLIN)*
- Contract Sub Line Item (SLIN)*
- Event Line Item (ELIN)*
- Appr. Limitation Subhead*
- Department Regular Code*
- Department Transfer Code*
- Main Account Code*
- Sub Account Code*
- Period of Availability Fiscal Year Date*
- Reimbursable Flag Indicator*
- Budget Activity Identifier*
- Budget Sub Activity Identifier*
- Budget Line Identifier*
- FMS Customer Code*
- FMS Case Identifier*
- FMS Case Line Identifier*
- Foreign Non-Federal Indicator*
- Trading Partner Indicator Code*
- Business Partner Number*
- Agency Accounting Identifier Code*
- Funding Career Identifier*
- Cost Center Identifier*
- Project Identifier*
- Activity Identifier*
- Work Order Number*

Accounts Receivable Principal Balance Debtor

- Action Code*
- External Employment Debt ID*
- External Employment Debt ID*
- Debtor TIN*
- Debtor TIN Type*
- Debtor Name Lessor Business*
- Debtor Name First*
- Debtor Name Middle*
- Individual or Business*
- New Debtor TIN*
- Recall Request Reason for Debtor*

Accounts Receivable Principal Balance Individual Debtor

- Action Code*
- External Employment Debt ID*
- External Employment Debt ID*
- Debtor Generator*
- Debtor Gender*
- Date of Birth*
- Fed Civilian Employee*
- Fed Military Employee*

Accounts Receivable Principal Balance Business Debtor

- Action Code*
- External Employment Debt ID*
- External Employment Debt ID*
- Business Debtor Type*
- Business Type*
- Date of Incorporation*
- State of Incorporation*
- DUNS Number*
- Product Category ID*
- Date of Dissolution*

Accounts Receivable Principal Balance Header

- CDTR ID*
- Database Location ID*
- System Date*
- External Entry Transaction Identifier*

Acquisition Program Contract Information

Acquisition Program Contract Information

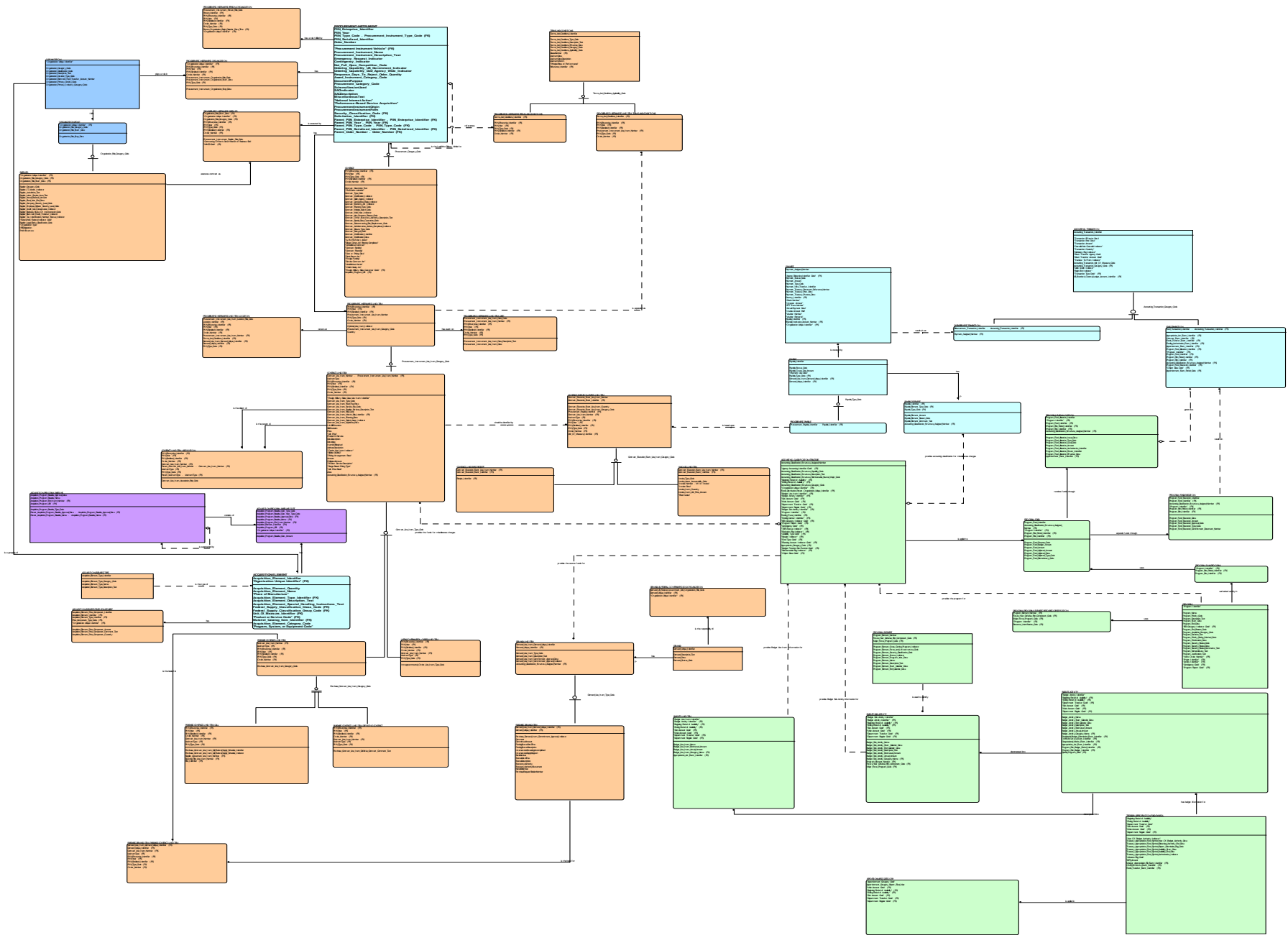

Acquisition Program Oversight

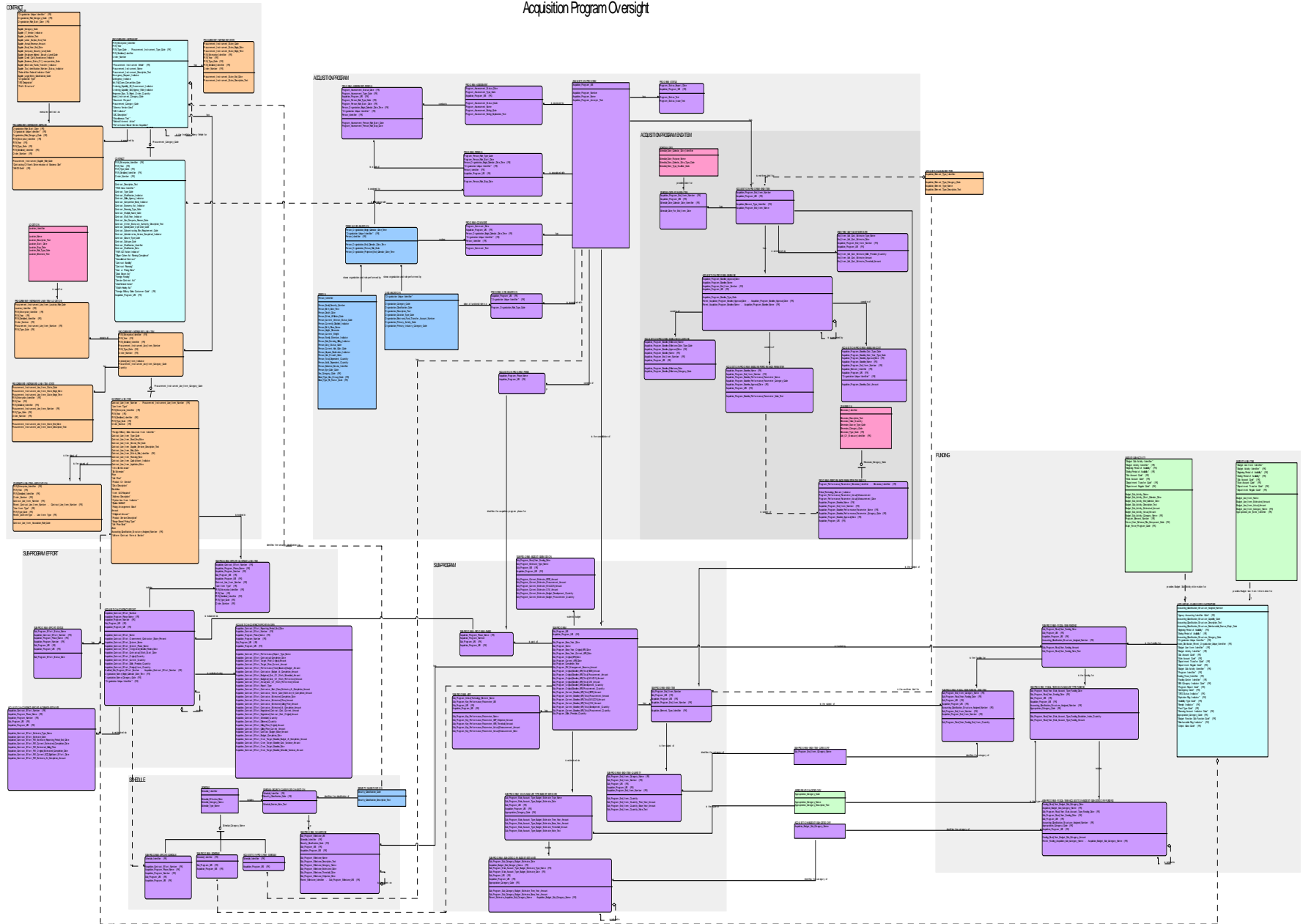

Budget - Defense Resource Plan

NSA/CSS INFORMATION REPORT
NSA/CSS REF ID: A66302
CLASSIFICATION: UNCLASSIFIED
AUTHORITY: 50 USC 3605 (a) (2)

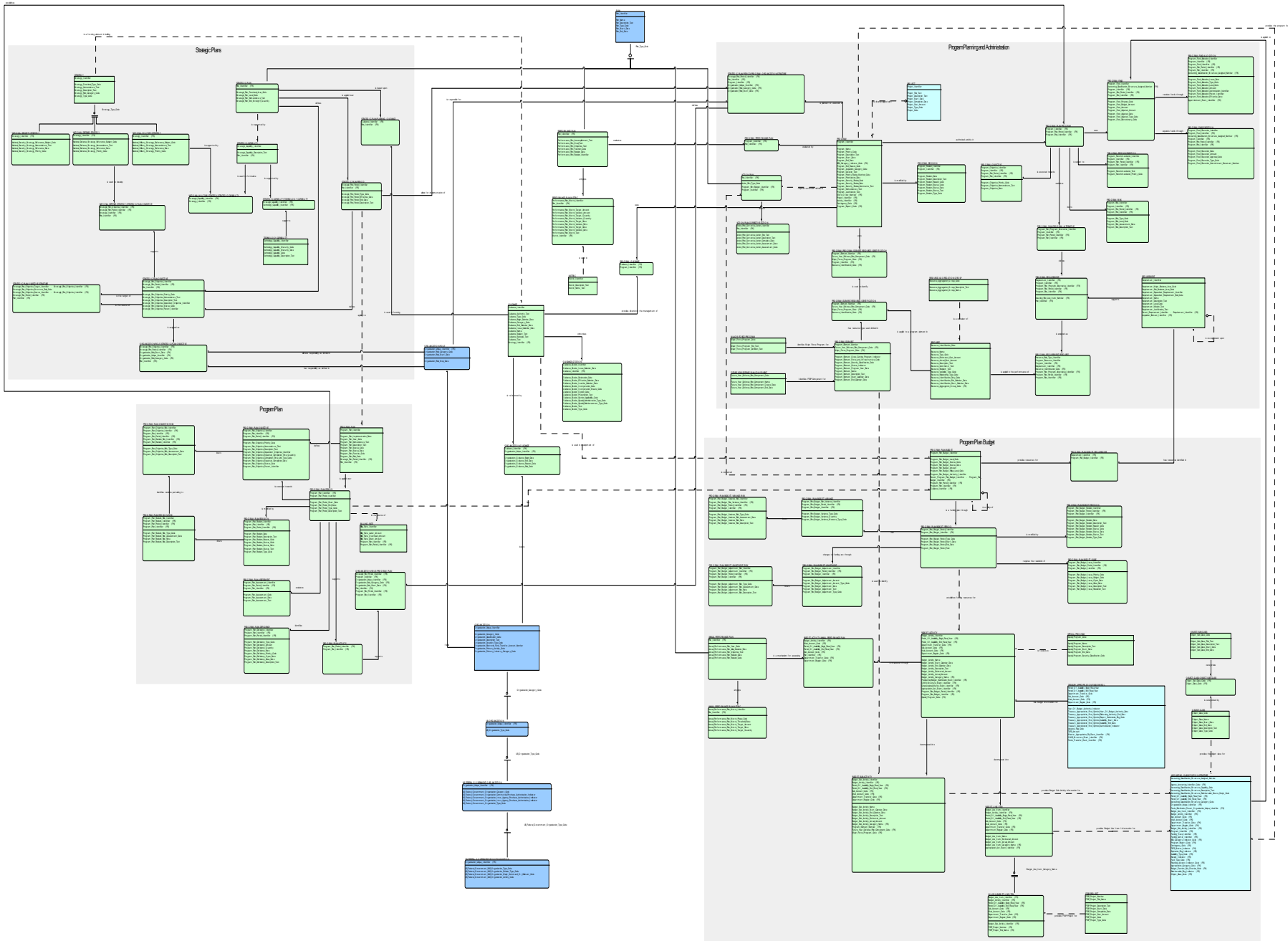

CHRIS - Compensation

Table with 1 column and multiple rows of compensation data.

Table with 1 column and multiple rows of compensation data.

Table with 1 column and multiple rows of compensation data.

Table with 1 column and multiple rows of compensation data.

Table with 1 column and multiple rows of compensation data.

Table with 1 column and multiple rows of compensation data.

Table with 1 column and multiple rows of compensation data.

Table with 1 column and multiple rows of compensation data.

Table with 1 column and multiple rows of compensation data.

Table with 1 column and multiple rows of compensation data.

Table with 1 column and multiple rows of compensation data.

Table with 1 column and multiple rows of compensation data.

Table with 1 column and multiple rows of compensation data.

Table with 1 column and multiple rows of compensation data.

Table with 1 column and multiple rows of compensation data.

Table with 1 column and multiple rows of compensation data.

Table with 1 column and multiple rows of compensation data.

Table with 1 column and multiple rows of compensation data.

Confirmed Collection Cross Servicing (OV-7 Logical Data Model Subject Area)
 System Architect
 Tue Feb 16, 2010 21:17
 Comment
 A confirmed collection received from Treasury Cross Servicing that has been verified and interpreted to accurately record the collection to the general ledger account and liquidate the outstanding receivable.

Confirmed Collection Cross Servicing

Confirmed Collection Cross Servicing Batch Control

- 'FAST Code'
- ALC
- Station
- 'Record Count'
- 'Collection Amount'
- 'Collection Count'
- 'Reversal Count'
- 'Reversal Amount'
- 'Net Collections'
- 'Excess Offset Amount'
- 'Excess Reversal Amount'
- 'Total Fee Amount'
- 'Offset Cycle'
- 'Ending Date of Collection Cycle'
- 'DMS Program Year'

Confirmed Collection Cross Servicing Header

- 'FAST Code'
- ALC
- Identifier
- 'File Date'

Confirmed Collection Cross Servicing Trailer

- 'FAST Code'
- ALC
- Identifier
- 'Record Count'
- 'Collection Amount'
- 'Collection Count'
- 'Reversal Count'
- 'Reversal Amount'
- 'Net Collections'
- 'Excess Offset Amount'
- 'Excess Reversal Amount'
- 'Total Fee Amount'
- 'Offset Cycle'
- 'Ending Date of Collection Cycle'
- 'DMS Program Year'

Confirmed Collection Cross Servicing Collection Detail

- 'FAST Code'
- ALC
- Station
- 'Agency Debt ID'
- 'Agency Debtor ID'
- 'Type Indicator'
- 'Debtor TIN'
- 'SIGNED Collection Amount'
- 'SIGNED Fee Amount'
- 'Year of Original Offset'
- 'Reversal Ind'
- 'Debtor Name Last or Business'
- 'Debtor Name First'
- 'Payment Status'
- 'Payee Name'
- 'Payee Address 1'
- 'Payee Address 2'
- 'Payee Address City'
- 'Payee Address State'
- 'Payee Address Zip Code'
- 'Payee Address Country'
- 'Name Control'
- 'Individual or Business'
- 'Offset Cycle'
- 'Payment Date'
- 'Year of Offset'
- 'TCP Trace Number'
- 'Payment Type'
- 'Agency Name Control'
- 'OCSE Indicator'
- 'Applied Principal'
- 'Applied Interest'
- 'Applied Penalty'
- 'Applied Admin Costs'
- 'Applied Overage'
- 'Applied DMS Fees'
- 'Applied PCA Fees'
- 'Applied TCP Fees'
- 'Applied DOJ Fees'
- 'Charged DMS Fees'
- 'Charged PCA Fees'
- 'Charged TCP Fees'
- 'Charged DOJ Fees'
- 'SIGNED IPAC Net Transfer Amt'
- 'IPAC Trans Date'
- 'IPAC Reference Num'
- 'Originating Txn Id of the Payment or Adjustment'
- 'Originating Txn Id of the Reversal'
- 'Principal TAS'
- 'Interest TAS'
- 'Penalty TAS'
- 'Admin Cost TAS'
- 'Collection Tool Indicator'

Confirmed Collection TOP (OV-7 Logical Data Model Subject Area)
System Architect
Tue Feb 16, 2010 21:00
Comment

A confirmed collection received from Treasury Offset Program that has been verified and interpreted to accurately record the collection to the general ledger account and liquidate the outstanding receivable.

Confirmed Collection TOP

Confirmed Collection TOP Collection Detail

"FAST Code"
ALC
Station
"Agency Debt ID"
"Agency Debtor ID"
"Type Indicator"
"Debtor TIN"
"SIGNED Collection Amount"
"SIGNED Fee Amount"
"Year of Original Offset"
"Reversal Ind"
"Debtor Name Last or Business"
"Debtor Name First"
"Payment Status"
"Payee Name"
"Payee Address 1"
"Payee Address 2"
"Payee Address City"
"Payee Address State"
"Payee Address Zip Code"
"Payee Address Country"
"Name Control"
"Individual or Business"
"Offset Cycle"
"Payment Date"
"Year of Offset"
"TOP Trace Number"
"Payment Type"
"Agency Name Chrtl"
"OCSE Indicator"
"Applied Principal"
"Applied Interest"
"Applied Penalty"
"Applied Admin Costs"
"Applied Overage"
"Applied DMS Fees"
"Applied PCA Fees"
"Applied TOP Fees"
"Applied DOJ Fees"
"Charged DMS Fees"
"Charged PCA Fees"
"Charged TOP Fees"
"Charged DOJ Fees"
"SIGNED IPAC Net Transfer Amt"
"Originating Txn Id of the Payment or Adjustment"
"Originating Txn Id of the Reversal"
"Principal TAS"
"Interest TAS"
"Penalty TAS"
"Admin Cost TAS"
"Collection Tool Indicator"

Confirmed Collection TOP Header

"FAST Code"
ALC
Identifier
"File Date"

Confirmed Collection TOP Batch Control

"FAST Code"
ALC
Station
"Record Count"
"Collection Amount"
"Collection Count"
"Reversal Count"
"Reversal Amount"
"Net Collections"
"Excess Offset Amount"
"Excess Reversal Amount"
"Total Fee Amount"
"Offset Cycle"
"Ending Date of Collection Cycle"
"DMS Program Year"

Confirmed Collection TOP Trailer

"FAST Code"
ALC
Identifier
"Record Count"
"Collection Amount"
"Collection Count"
"Reversal Count"
"Reversal Amount"
"Net Collections"
"Excess Offset Amount"
"Excess Reversal Amount"
"Total Fee Amount"
"Offset Cycle"
"Ending Date of Collection Cycle"
"DMS Program Year"

Contract

Contract ID: [Blank]
Contract Name: [Blank]
Contract Type: [Blank]
Contract Status: [Blank]

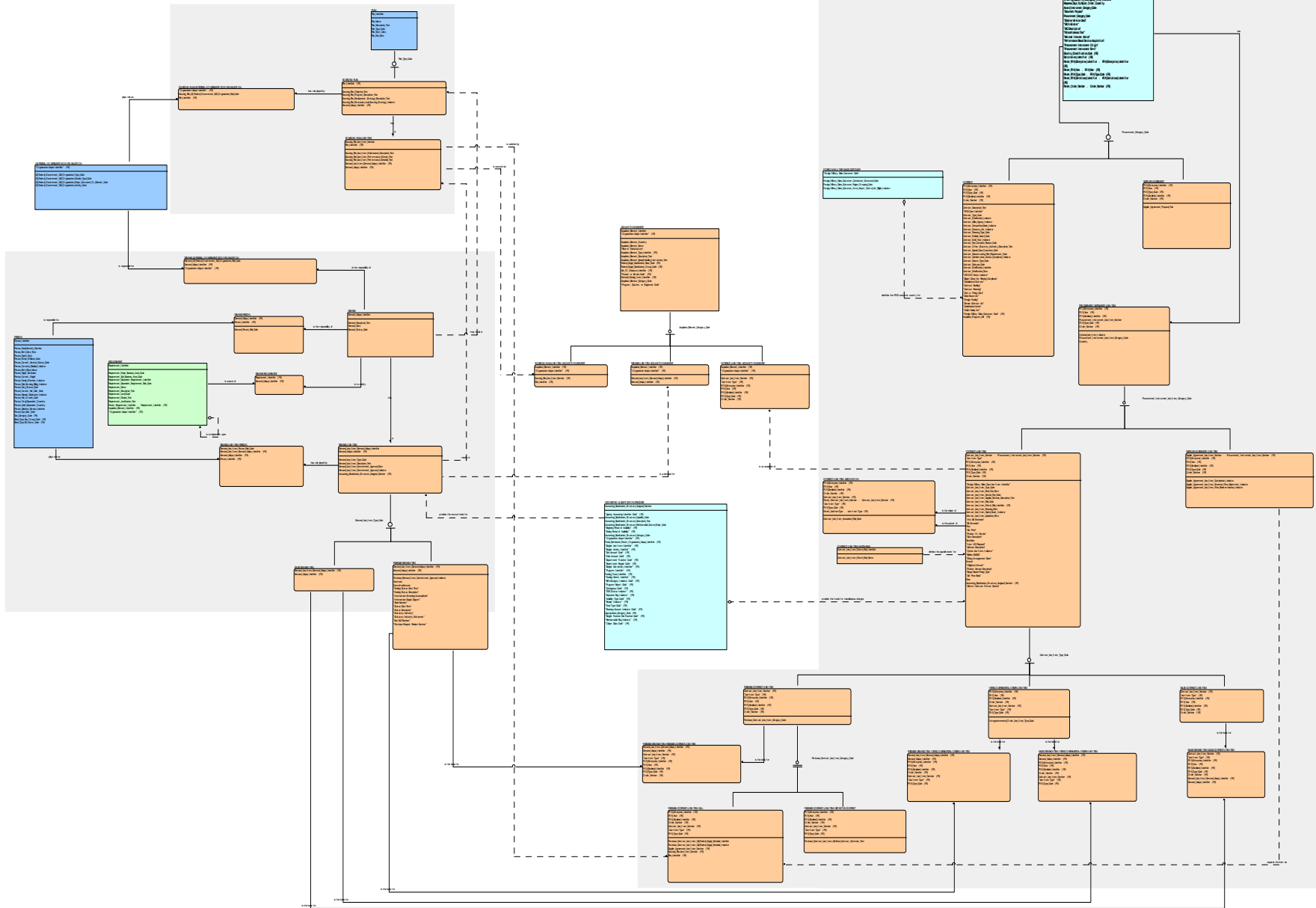

Contract Execution Event

Small Event - 200 Lines of Code Small Event - 200 Lines of Code Small Event - 200 Lines of Code

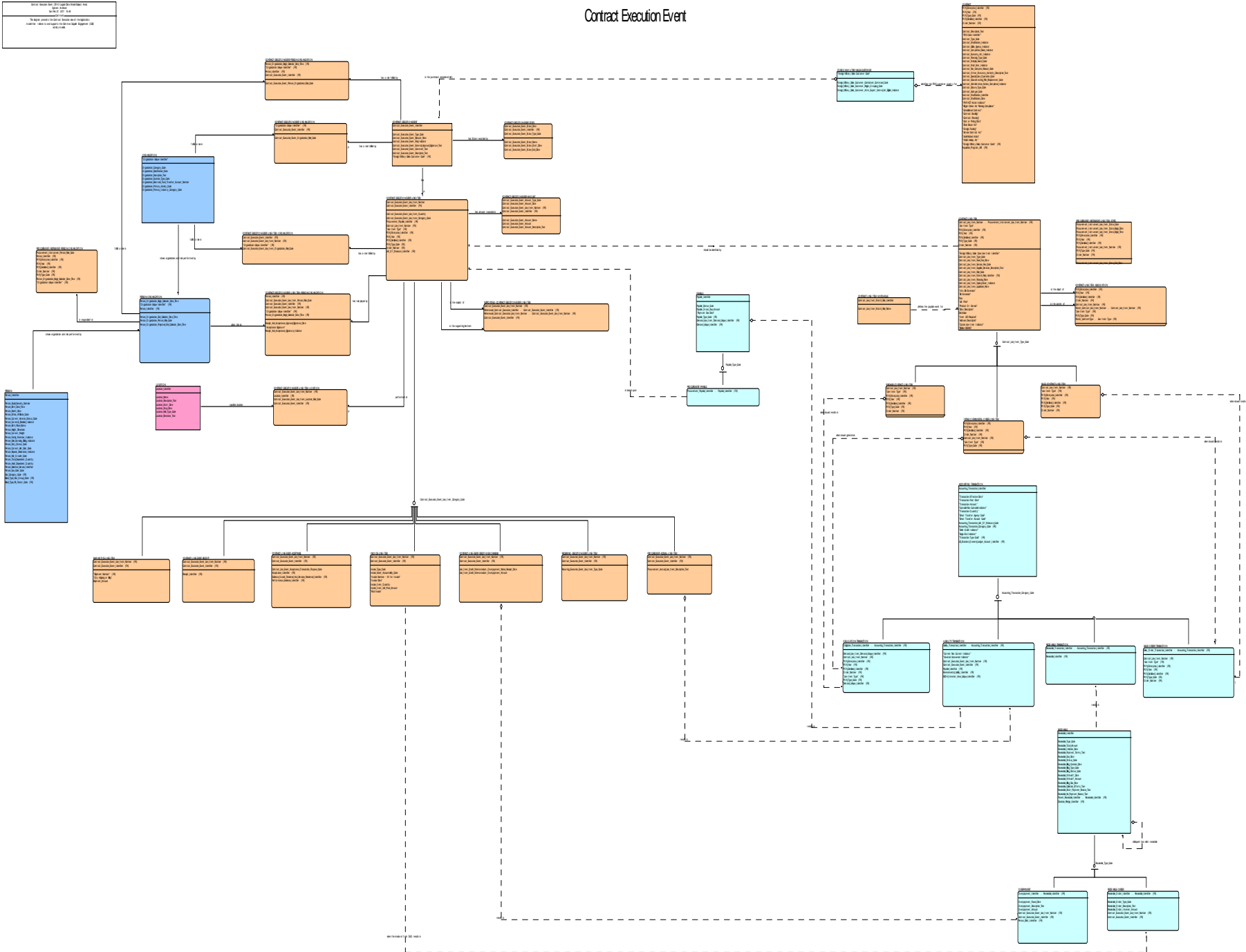

Cost

Cost (OV7 Logical Data Model Subject Area)
 System Architect
 Fri Dec 03 2010 17:03
 — Comment
 The purpose of this diagram is to show the entities involved with the Cost Accounting areas.

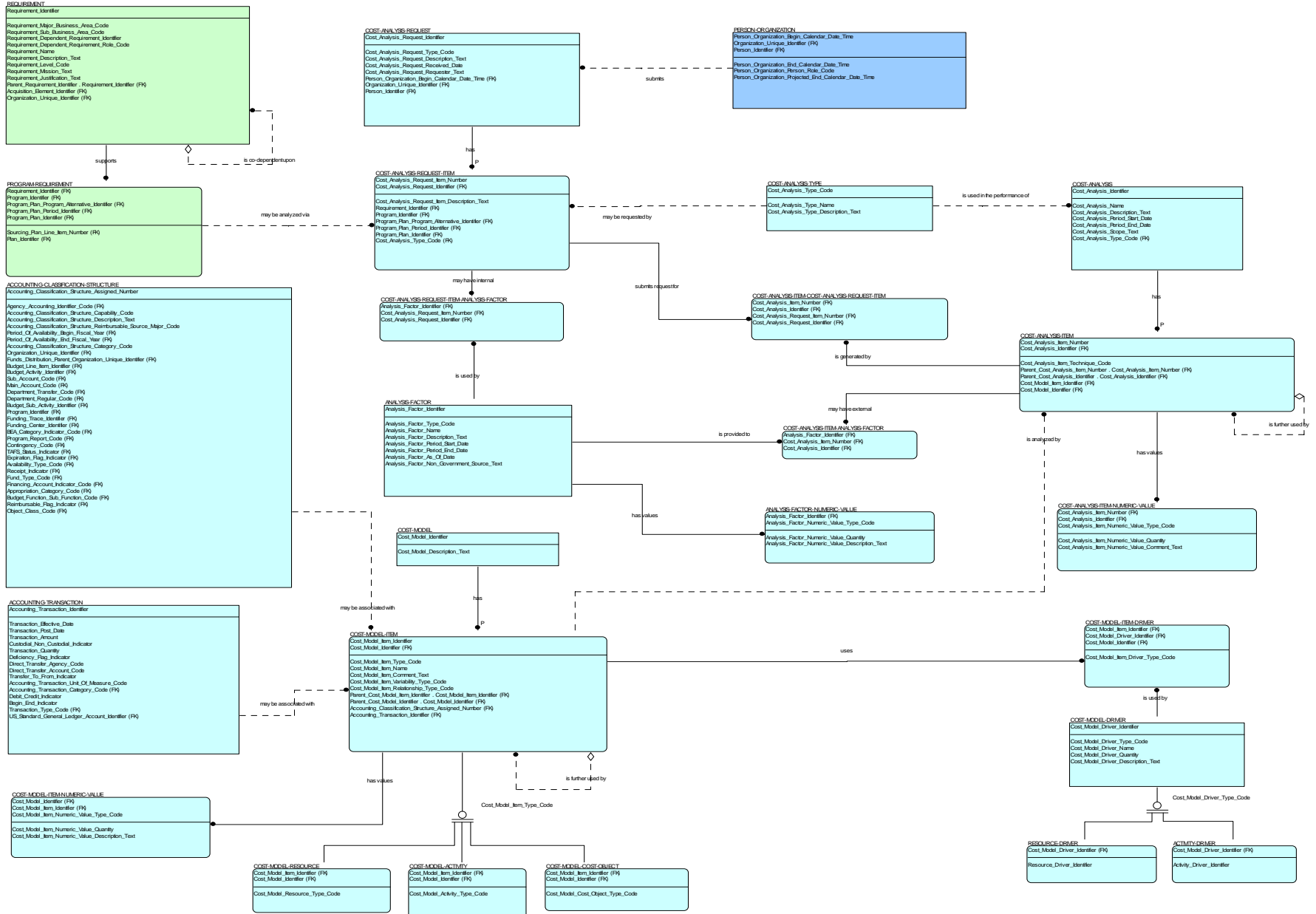

Disbursement and Payables

Business Analyst: [Name]
 Date: [Date]
 Version: [Version]

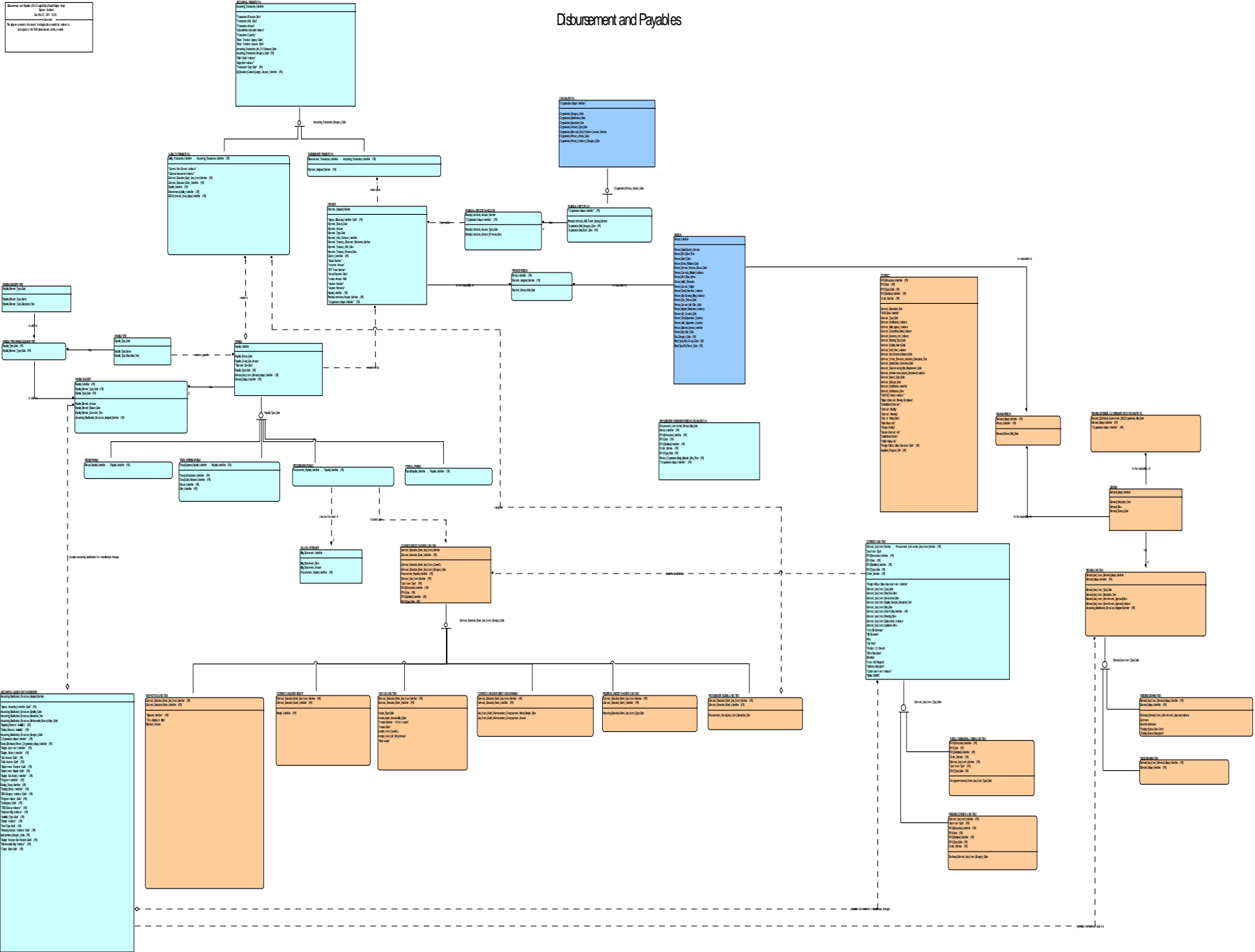

Document(DH-7 Logical Data Model Subject Area)
 System Architect
 Fri Dec 03 2010 16:51
 Comment
 The Document view presents the structure for a document within the BEA

The central entity is DOCUMENT, which does not represent a document, but rather the essential information about a document. The documents may be available in various media (ex. .hardcopy, CD), and formats, (ex. Word, PDF, CAD file). The media may be located in various locations.

The association of one document to another is captured in the entity, DOCUMENT-ASSOCIATION. Examples of associations would be:

- supersedes
- referenced by
- is parent

Document

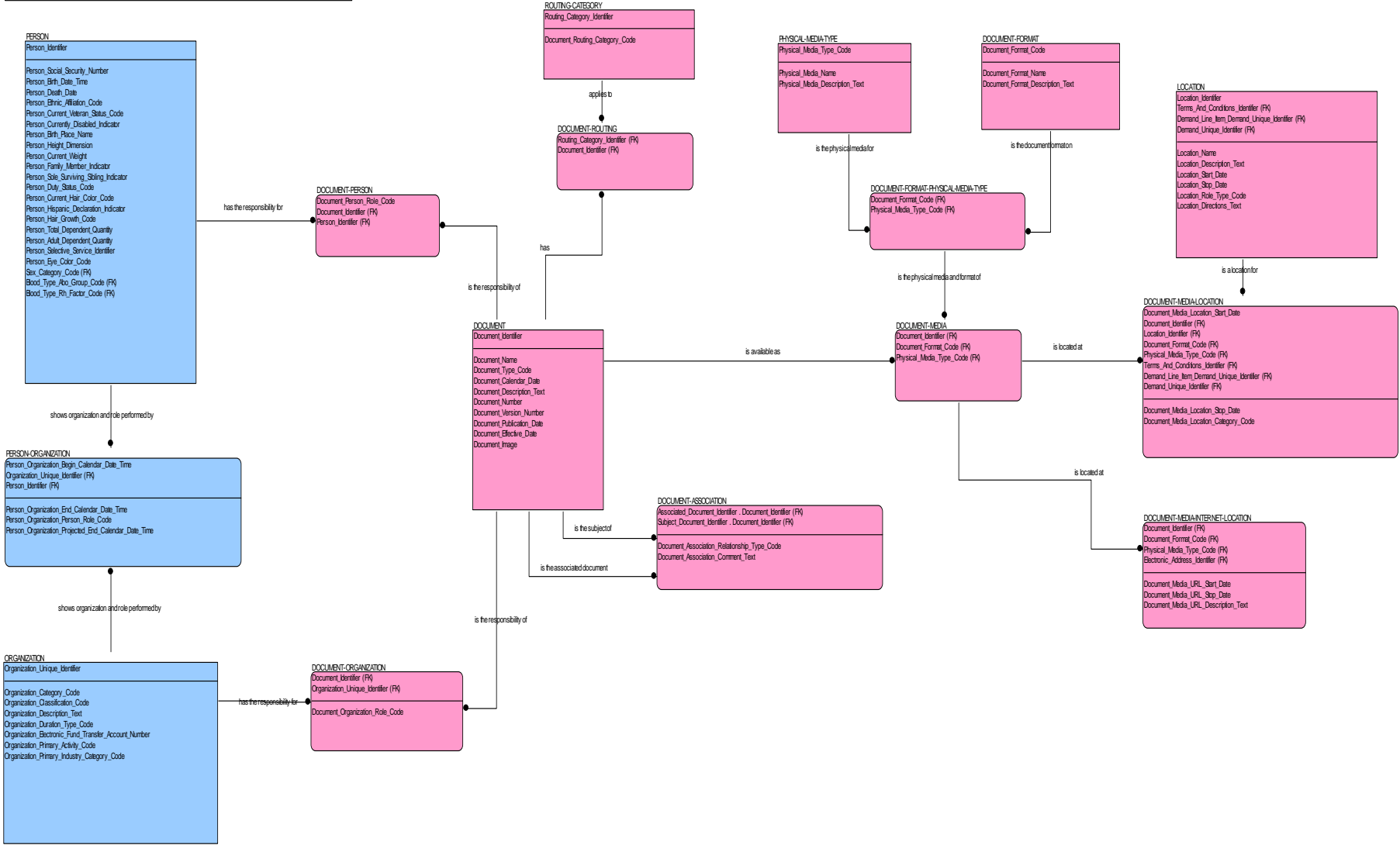

Enterprise Information Management (EIM) 2 Logical Data Model Subject Area
Project: EIM-0000
Friday, February 01, 2013 12:25 PM
Logical representation of enterprise information needed to manage DOD facility energy information.

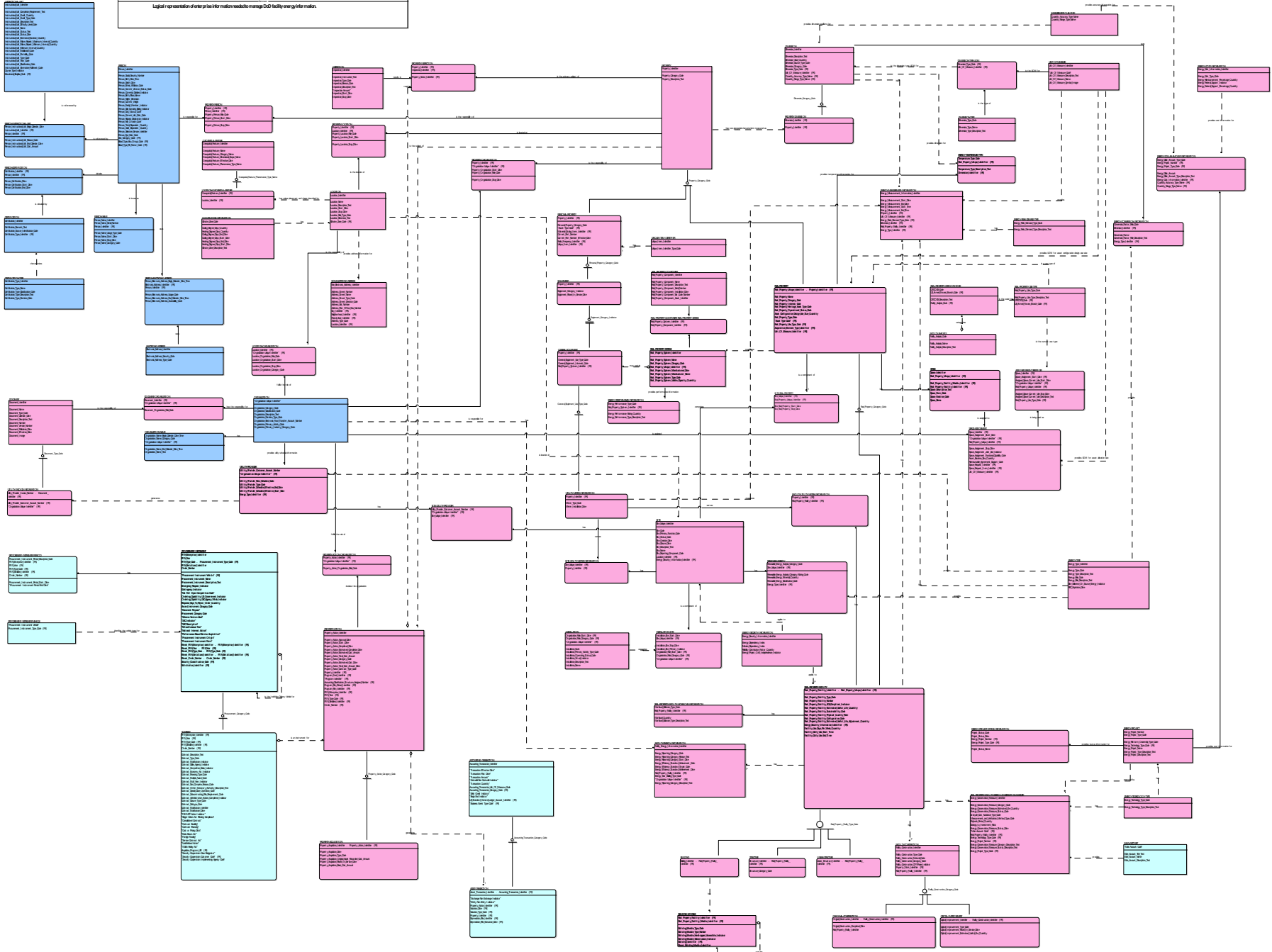

Environmental Liability

Environmental Liability
This diagram illustrates the various components and sub-sections of environmental liability, categorized by color-coded boxes (pink, blue, cyan, orange, and green). The diagram is organized into a hierarchical structure, showing the relationships between different areas of liability. The main categories are: Environmental Liability (Pink), Environmental Remediation (Blue), Environmental Assessment (Cyan), Environmental Impact Assessment (Orange), and Environmental Monitoring (Green).

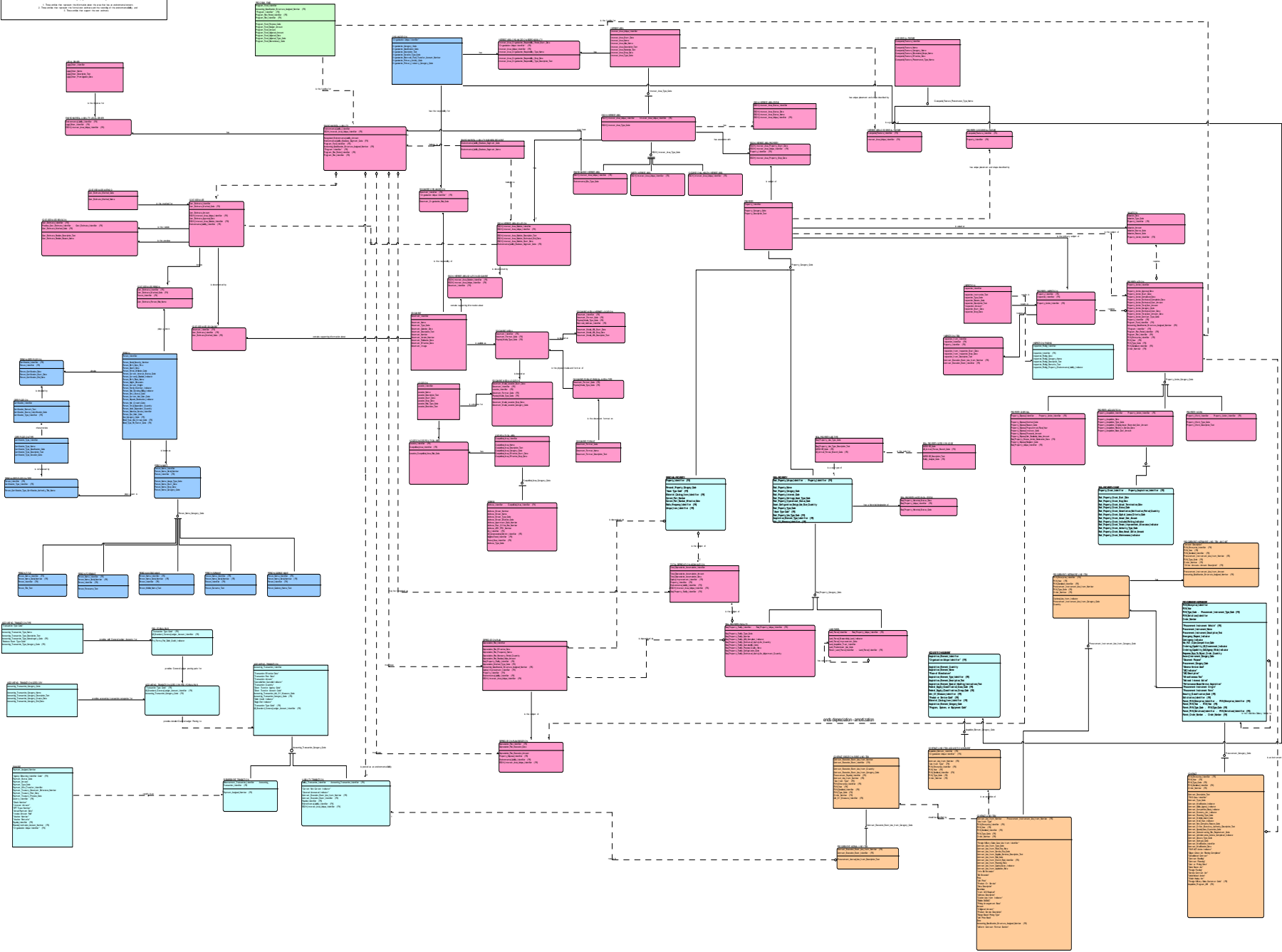

ESCH Compliance Agreement

ESCH Compliance Agreement (U7 Legal Data/Mini Subject Area) System Architect Tue Sep 28 22:10 18:33 Comment
The ESCH community often makes agreements with its stakeholders. The Compliance Agreement views supports development of and compliance with agreements such as permits and codes of conduct.

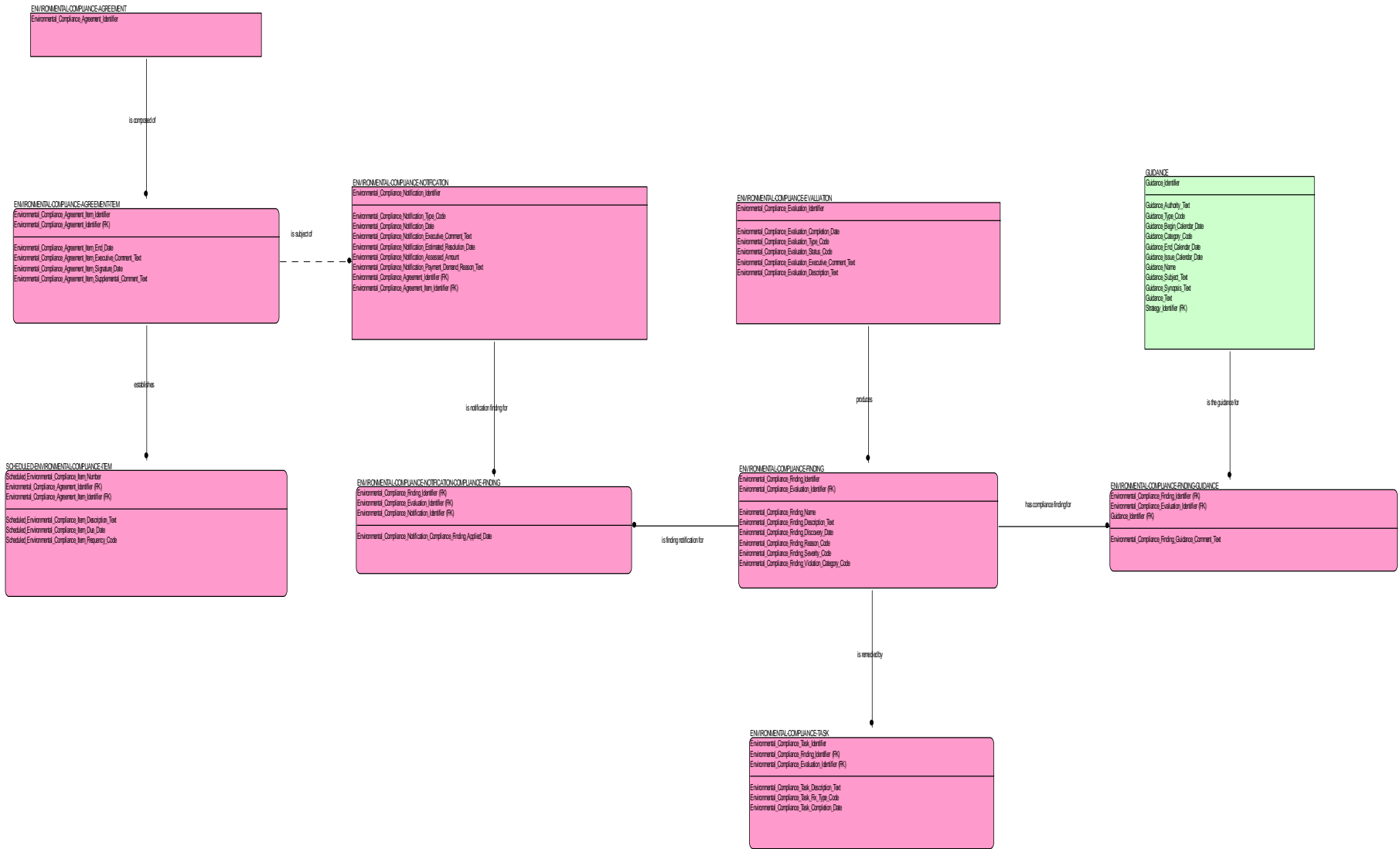

Geospatial Feature

Geospatial Feature (DT Logical Data Model Subject Area)
 System Architect
 Feb 20, 2010 10:35
 -Comment
 The purpose of this view Geospatial Feature is to present the structure for
 Geospatial Feature within the SDI network to be geospatial
 feature: PROPERTY, INTEREST, AREA, LOCATION and
 GEOSPATIAL_AREA. The central entity is GEOSPATIAL_FEATURE,
 which together with the coordinate reference system entities, provide the
 essential information required to correct representation of a geospatial
 location. These entities can be used to describe placement and shape of
 elements in the network, relationship to a coordinate reference
 system. They can also be used to collect coordinate information
 about situation.
 The view also contains essential information about the techniques of
 geospatial features, vector and coverage, including metadata identifier.
 The metadata identifier provides a way to store related information
 usually maintained by the Geographic Information Systems. This
 information can be used to compare, describe the coverage geospatial
 feature in a vector database. Some of those

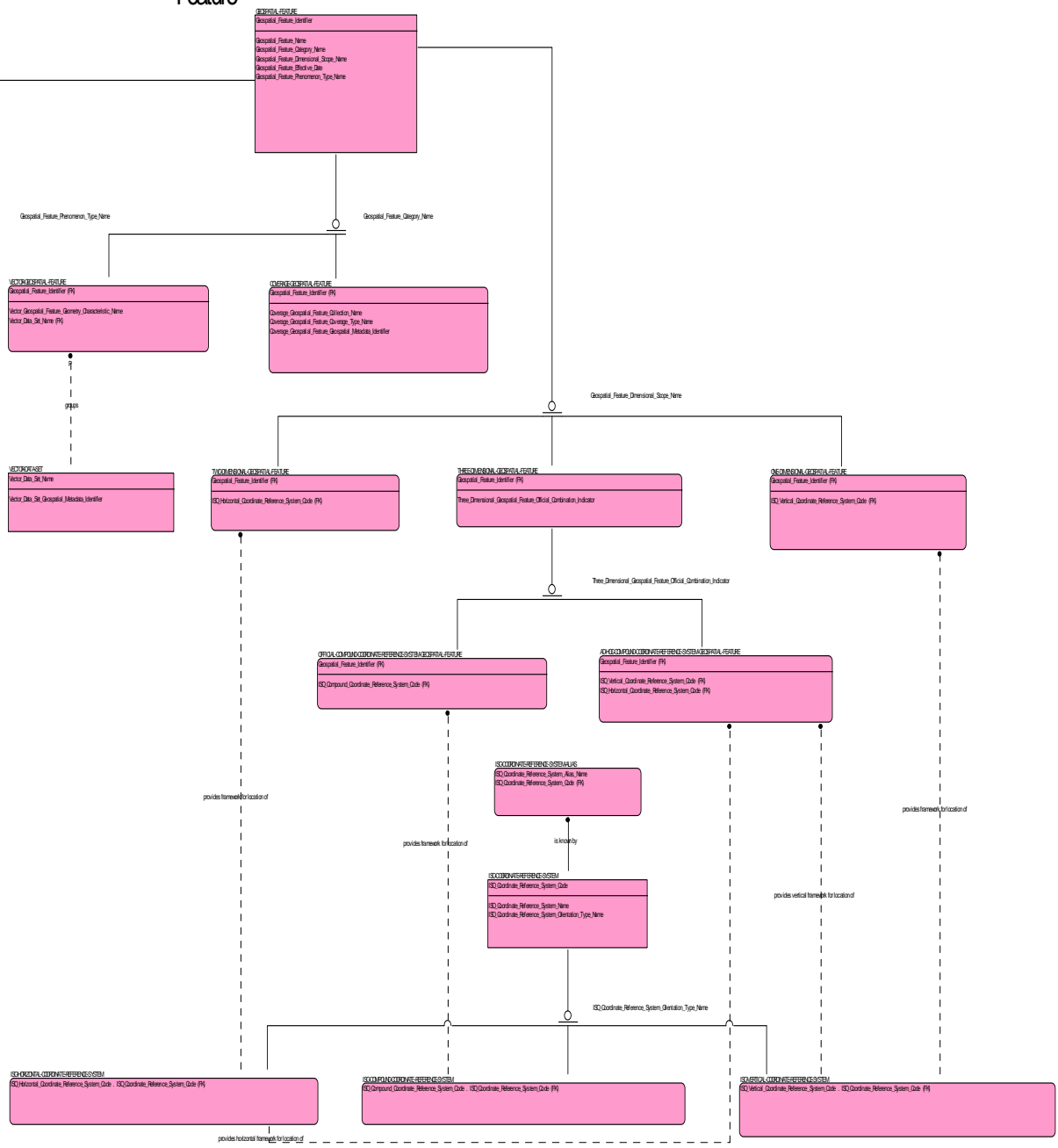
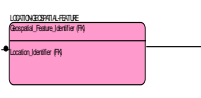
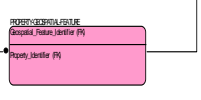
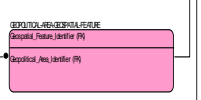
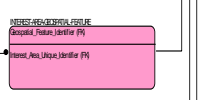
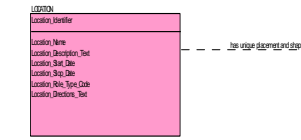
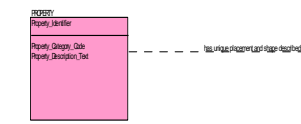
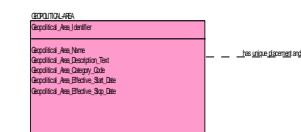
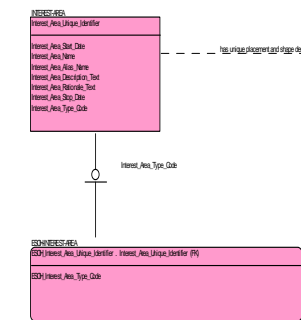

HRM Integrated View

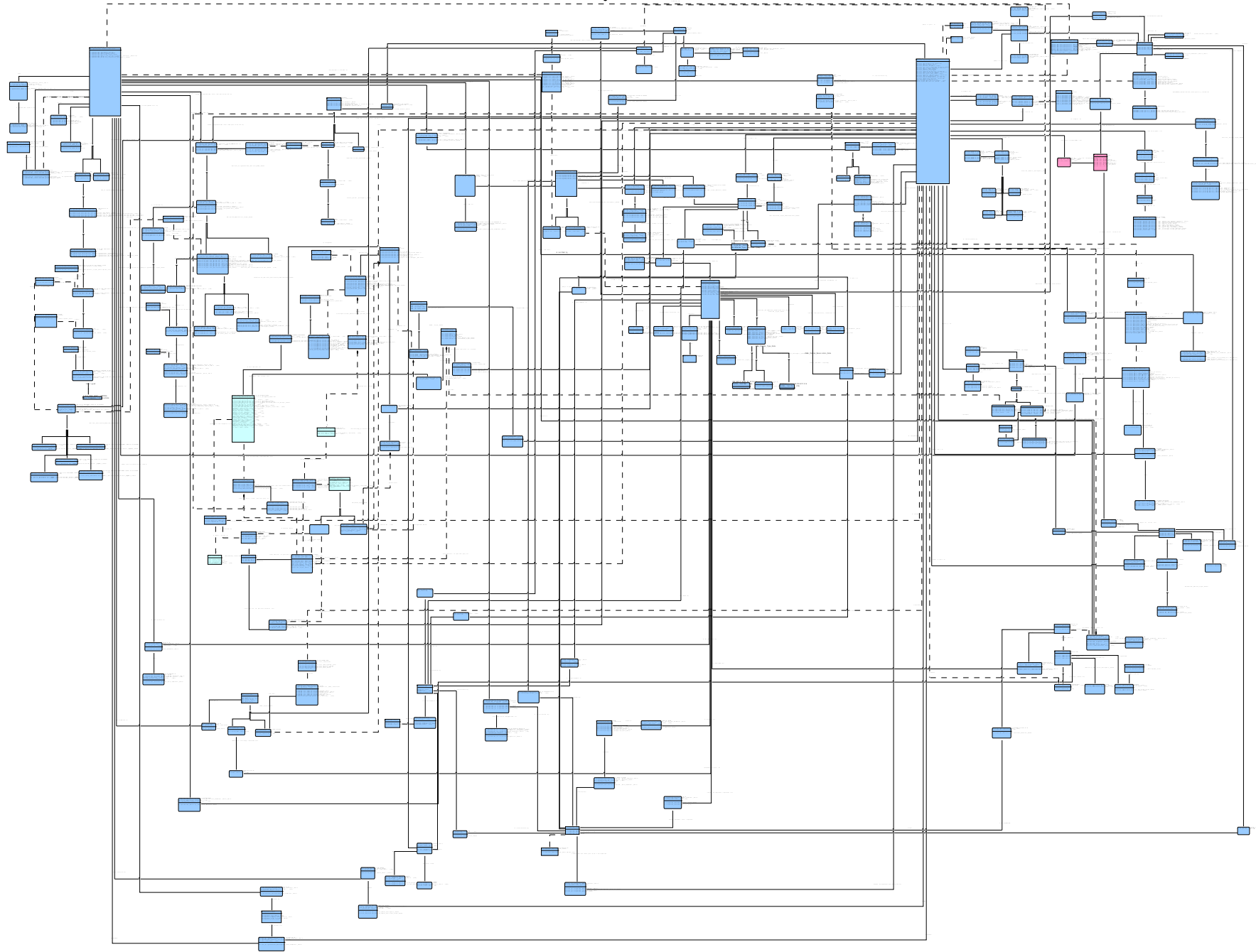

HRMO Overview

HRMO Overview

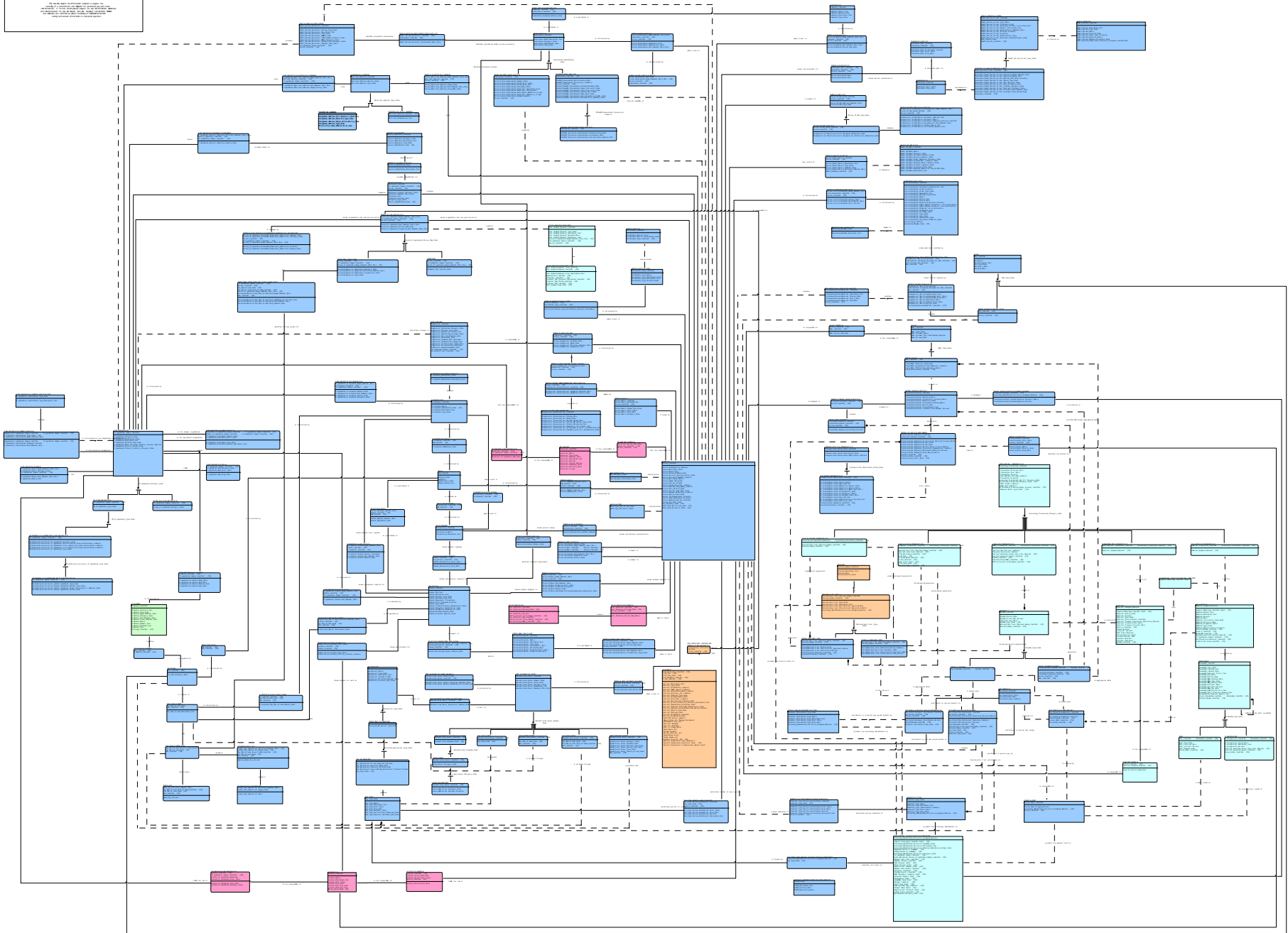

Inspector (V7 Logical Data Model Subject Area)
 System Architect
 Thu Dec 02 2010 10:42
 Comment
 This inspection view depicts entities and relationships between them needed to support the functionality for Real Property Management inspection status.

Inspection

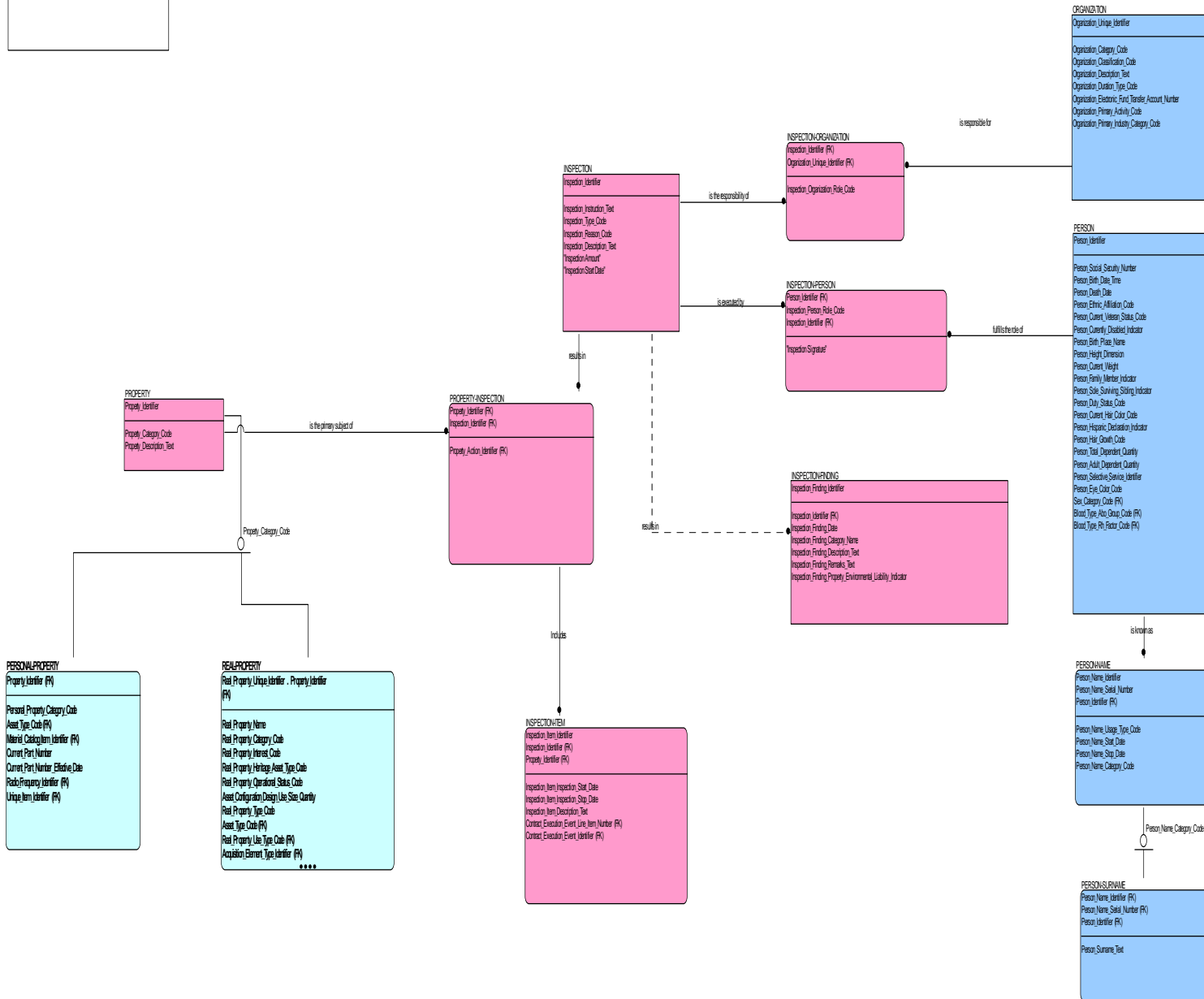

Organization Management

1. General Information
2. Organizational Structure
3. Organizational Chart
4. Organizational Description
5. Organizational History
6. Organizational Mission
7. Organizational Vision
8. Organizational Values
9. Organizational Culture
10. Organizational Strategy
11. Organizational Structure
12. Organizational Chart
13. Organizational Description
14. Organizational History
15. Organizational Mission
16. Organizational Vision
17. Organizational Values
18. Organizational Culture
19. Organizational Strategy

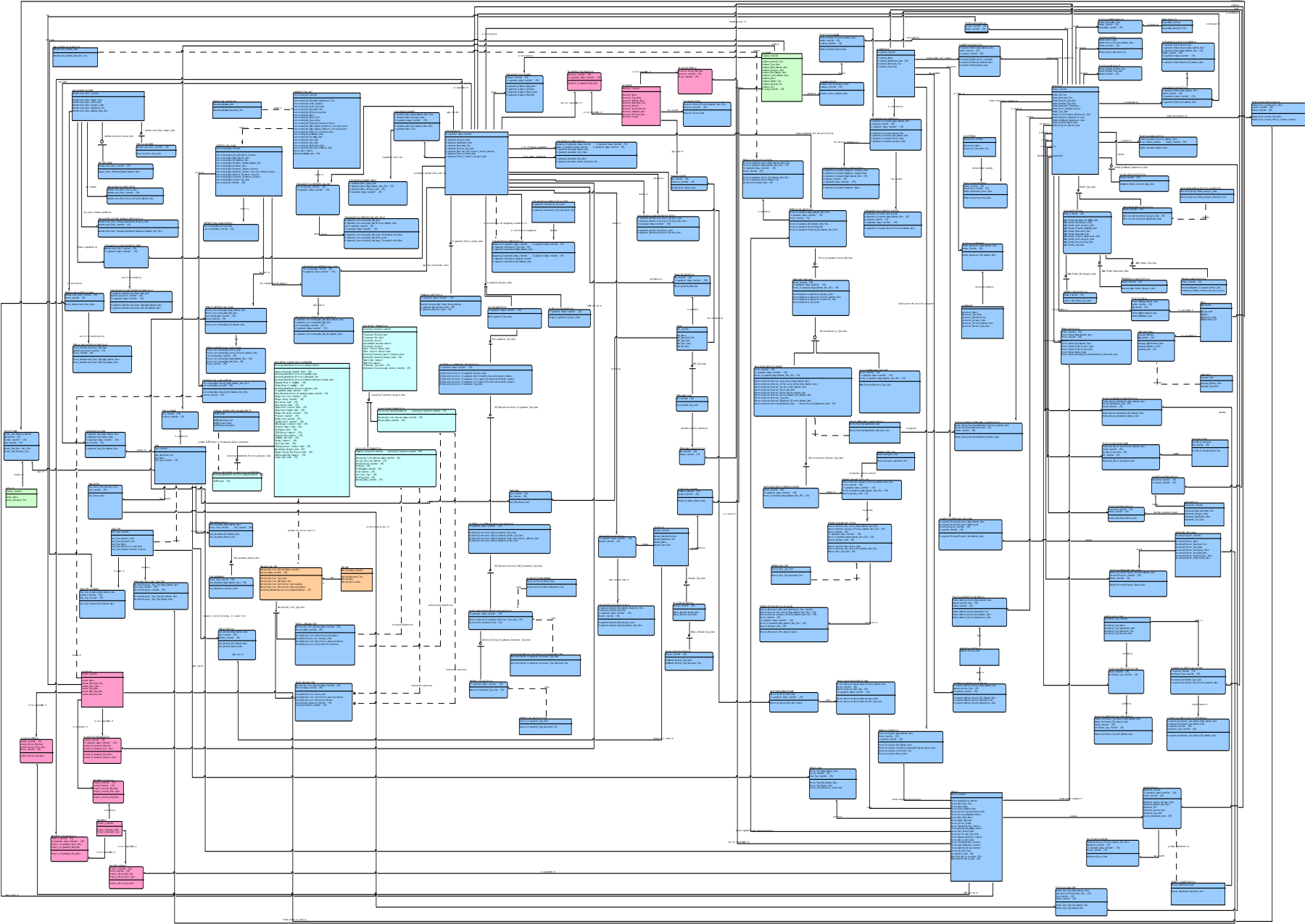

P2Party view (DW-2 Logical Data Model Subject Area)
System Architect
Wed Oct 19, 2011 16:13
This diagram represents the details of P2P (Procure-To-Pay).
This view was created from a copy of the "Procurement Instrument" view. P2P Entities were then added from other views. Some of these entities did not have any relationships to entities in "Procurement Instrument" so they will list as "stand-alone entities" or "Entity Fragments".

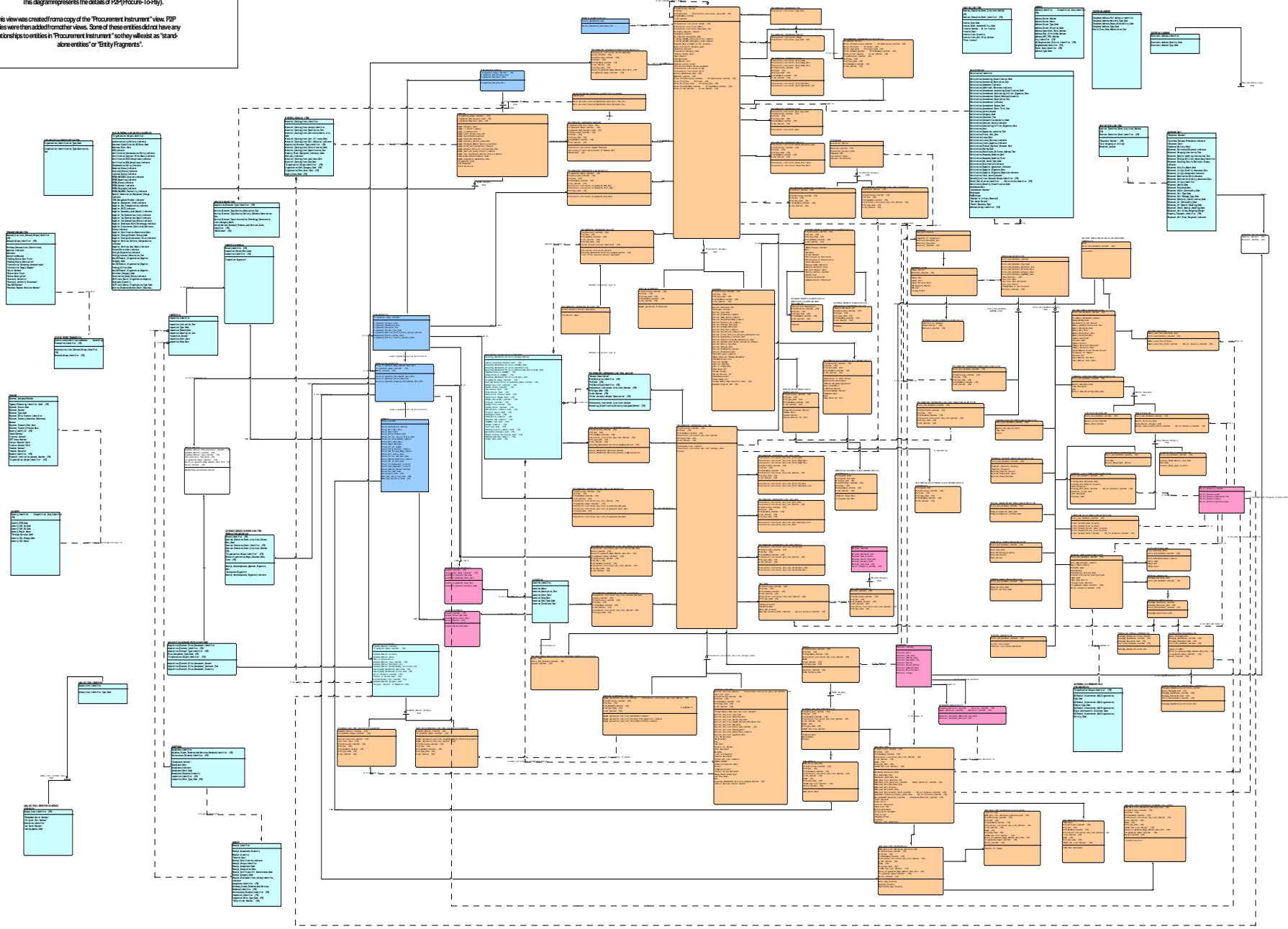

FDOnly view (DW2 Logical Data Model Subject Area)
SystemArchitect
Wed Oct 19, 2011 16:13
This diagram represents the details of the Procurement Data Standard (PDS).
The views were created from a copy of the "Procurement Instrument" view. PDS
Entities were then added from other views. Some of those entities did not have any
relationships to entities in "Procurement Instrument" so they will exist as "stand-
alone entities" or "Entity Fragments".

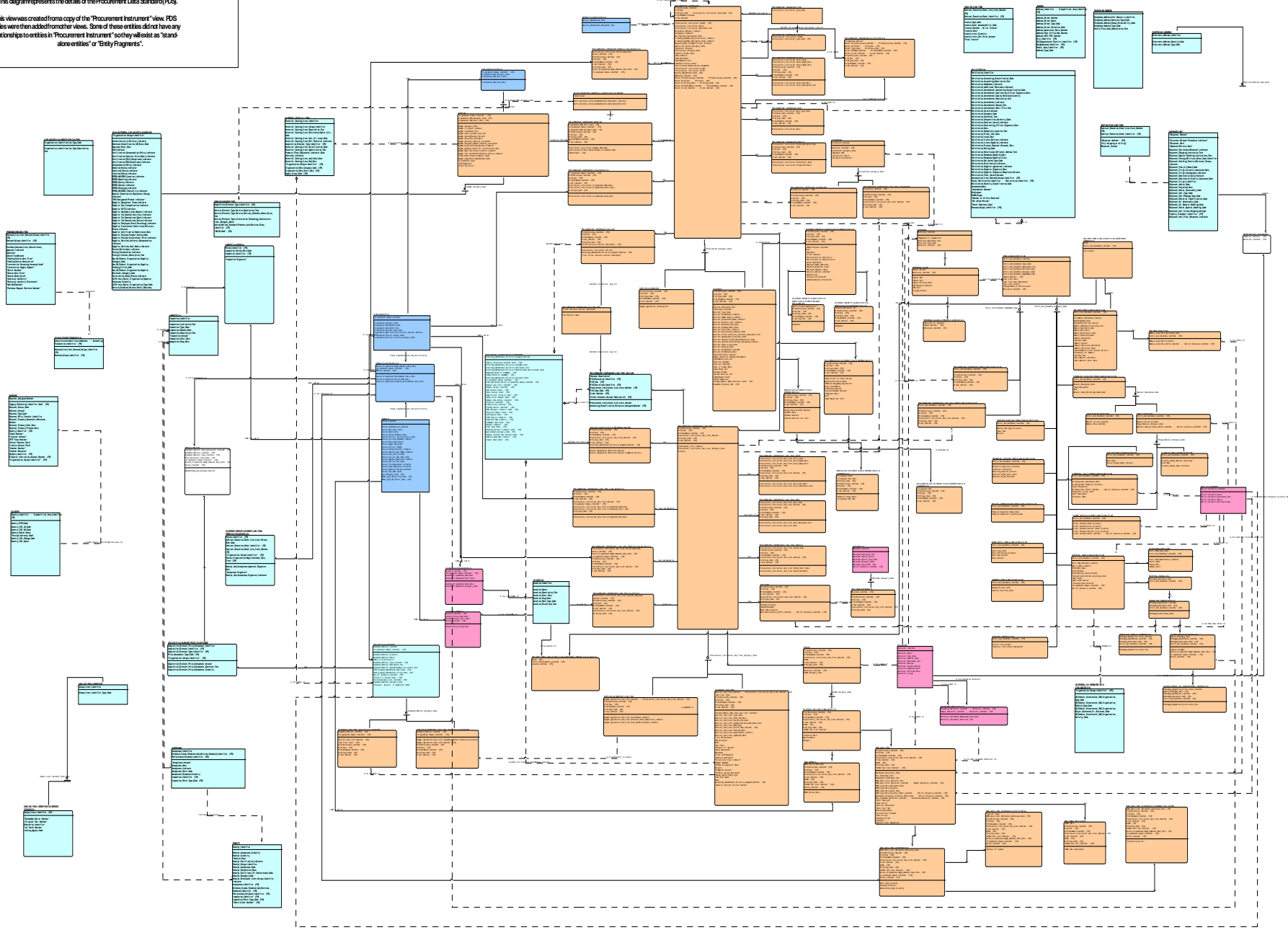

Small text box in the top left corner, likely containing a title or reference code.

Performance Management

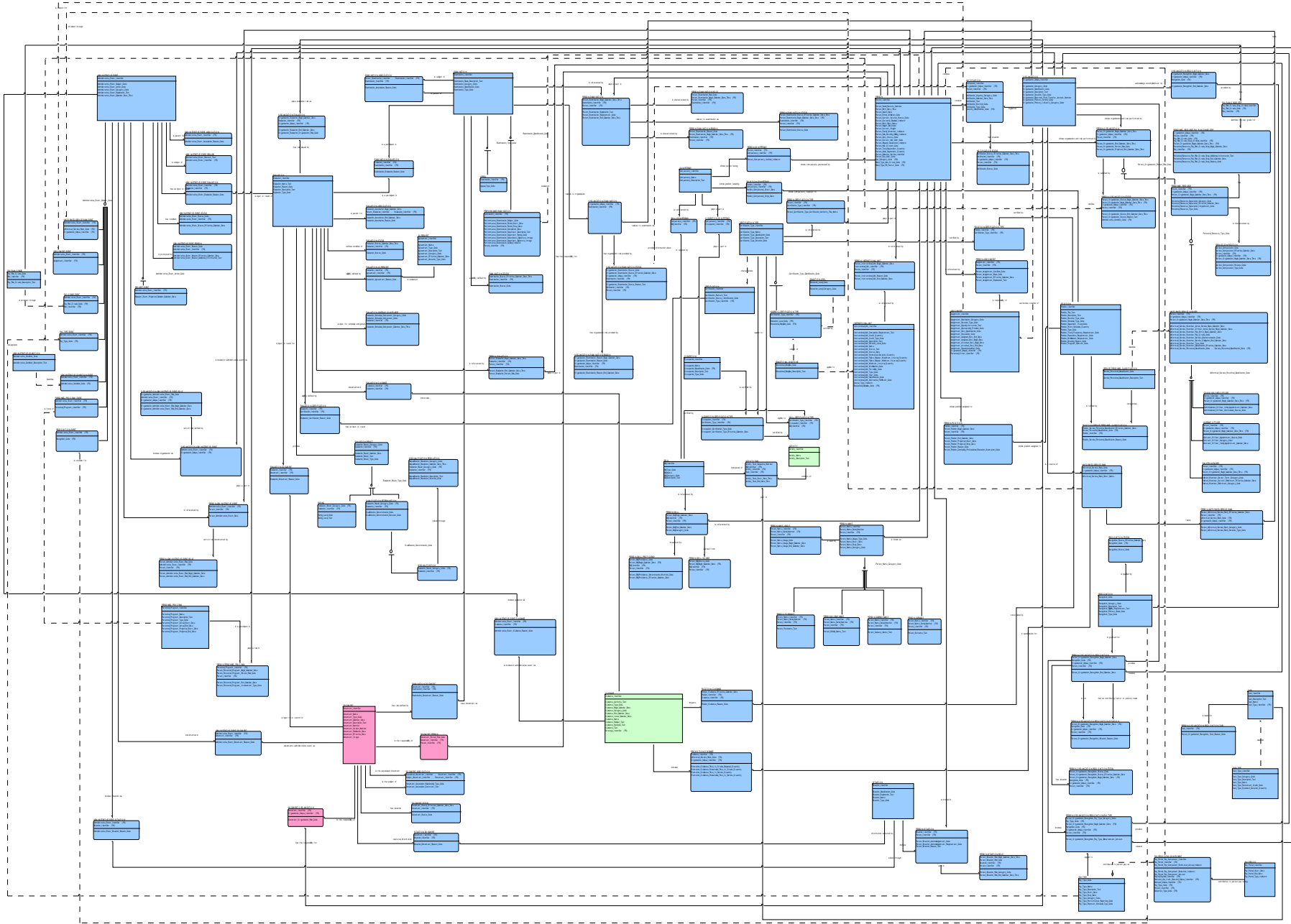

Personnel Agreement
2017-2018
The Personnel Agreement is a contract between the State of Michigan and the Michigan State Police Association. It sets forth the terms and conditions of employment for the members of the Association. The Agreement covers a wide range of issues, including wages, benefits, working conditions, and grievance procedures. It is a key document in the relationship between the State and the Association.

Personnel Agreement

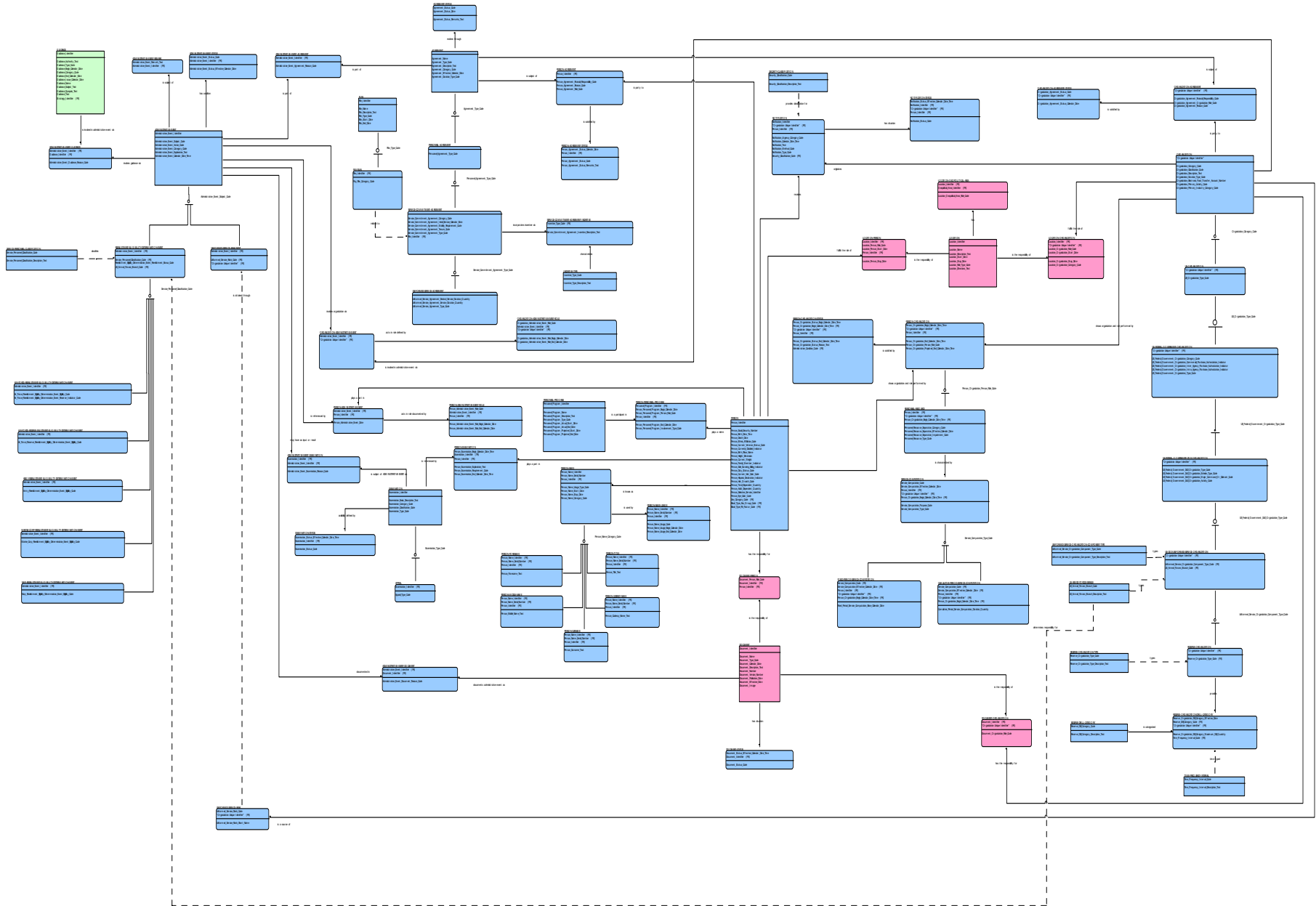

Procurement Data Standard

Appropriation Evidence

Appropriation Amount
Appropriation Date
Appropriation Signature
Appropriation Description
Amendment
Delivery Description
Location Value
Procurement Signature
Product O-Block
Qty Shipping/In-billing
Reference Date
Reference Value
Unit Price

Assignment to the Invoice

Unit Price

Amount of Payment

Delivery Description?
Invoice
Unit Price

Additional Assignment

Unit Price

Agency Contract

Address Description?
Agency Identifier
Agency Accounting Identifier
Agency Identifier
Approved By
Approval Change Value?
Approved Date
Approval Value?
Authorization Number?
Cancel Balance On Demand Amount?
Cancel Order Date?
Class Tot?
Contingency Contact
Contracting Agency Code?
Contracting Order Name?
Contracting Order Signature Date?
Contracting Order Signature Date?
Contracting Order Signature Date?
Data Acquisition Document Number?
Data Item Title?
Dealbreaker
Delivery Description?
Document Character?
Document Purpose?
Est. Approval?
Location Value?
Material Request Revision Number?
Material Ref?
Emergency Request Order?
Invoice
Shipping Indicator?
Shipping Method?
Invoice
Posting Status Date Time?
Posting Status Description?
Government Furnished Equipment (EFE) and Government Furnished Property (GFP)
Emergency Contracting Agency?
Issuing Agency?
Item Other Account Amount Description?
Last Time Description?
Max. Val?
Method Description?
Method Value?
Net Weight Amount?
Net Weight Amount Act/pt?
Other Signature?
Other Account Amount Description?
Posting Quantity?
Payment Frequency?
Payment Method?
Physical Description?
Quantity?
Requisition?
Price Break?
Posting Management Base?
Procurement Instrument Identifier?
Procurement Instrument Vehicle?
Procurement Instrument Description?
Procurement Instrument Election Code?
Procurement Instrument Form?
Procurement Instrument Origin?
Procurement Instrument Type Date?
Product O-Block?
Product O-Block?
Quantity Shipping/Billing?
Quantity Ship Date Value?
Quantity Unit/Comp Type?
Range Unit?
Range Date?
Receive Date?
Receiving Payment Amount?
Reference Description?
Reference Value?
Regulation I.C.?
System Version Label?
Technical Identifier?
Tax Number?
Tax Measurement?
Tax Social Condition?
Tax Date?
Technical Requirement?
Technical Actor?
Unit Price?
Unit?
Unit Description?
Volume Value?
Weight Value?
Year?
Zone?

Contract Information

Address Description?
Agency Identifier
Item And M. Orders Value?
Contracting Contact
Contracting Agency Code?
Delivery Description?
Foreign Funding?
Government Furnished Equipment (EFE) and Government Furnished Property (GFP)
Emergency Contracting Agency?
Item Other Account Amount Description?
Other Account Amount Description?
Product O-Block?
Receive Date?
Receiving Payment Amount?
Reference Value?
Reference Value?
Unit Price?
Zone?

Contract or Order Item Information

Address Description?
Agency Identifier
Item And M. Orders Value?
Dealbreaker
Delivery Description?
Foreign Funding?
Government Furnished Equipment (EFE) and Government Furnished Property (GFP)
Item Other Account Amount Description?
Other Account Amount Description?
Receive Date?
Reference Description?
Reference Value?

Payment of Order or Invoice

Posting Method?
Payment Frequency?
Payment Method?

Business Information

Final Payment Date?
Address Description?
Receipt Date?
Check Number?
Days Del?
Delivery Description?
Location Value?
Posting Method?
Invoice Amount Paid?
Invoice
Qty Shipping/Billing?
Receiving Payment Amount?
Reference Description?
Reference Value?
Unit Price?
Voucher Number?

Evidence of Goods Tendered and Services Rendered

Appropriation Amount?
Appropriation Date?
Appropriation Signature?
Address Description?
Agency Identifier?
Amendment
Delivery Description?
Location Value?
Procurement Signature?
Qty Shipping/Billing?
Reference Date?
Reference Description?
Reference Value?
Unit Price?

Evidence of Goods Tendered and Services Rendered (Contract)

Appropriation Amount?
Appropriation Date?
Appropriation Signature?
Address Description?
Agency Identifier?
Amendment
Delivery Description?
Location Value?
Procurement Signature?
Qty Shipping/Billing?
Reference Date?
Reference Description?
Reference Value?
Unit Price?

Payment Receipt

Final Payment Date?
Address Description?
Agency Identifier?
Check Date?
Delivery Description?
Location Value?
Invoice Amount Paid?
Payment Frequency?
Payment Method?
Quantity Shipping/Billing?
Receiving Payment Amount?
Reference Description?
Reference Value?
Unit Price?
Voucher Number?

Procurement Contract/Document

Agency Accounting Identifier?
Reference Value?
Unit Price?

Receipt by Contractive Order

Address Description?
Location Value?

Receipt/Contract Value

Check Number?
Contingency Contact?
Invoice Amount Paid?
Reference Value?
Voucher Number?

Send Information

Address Description?

Procurement Instrument

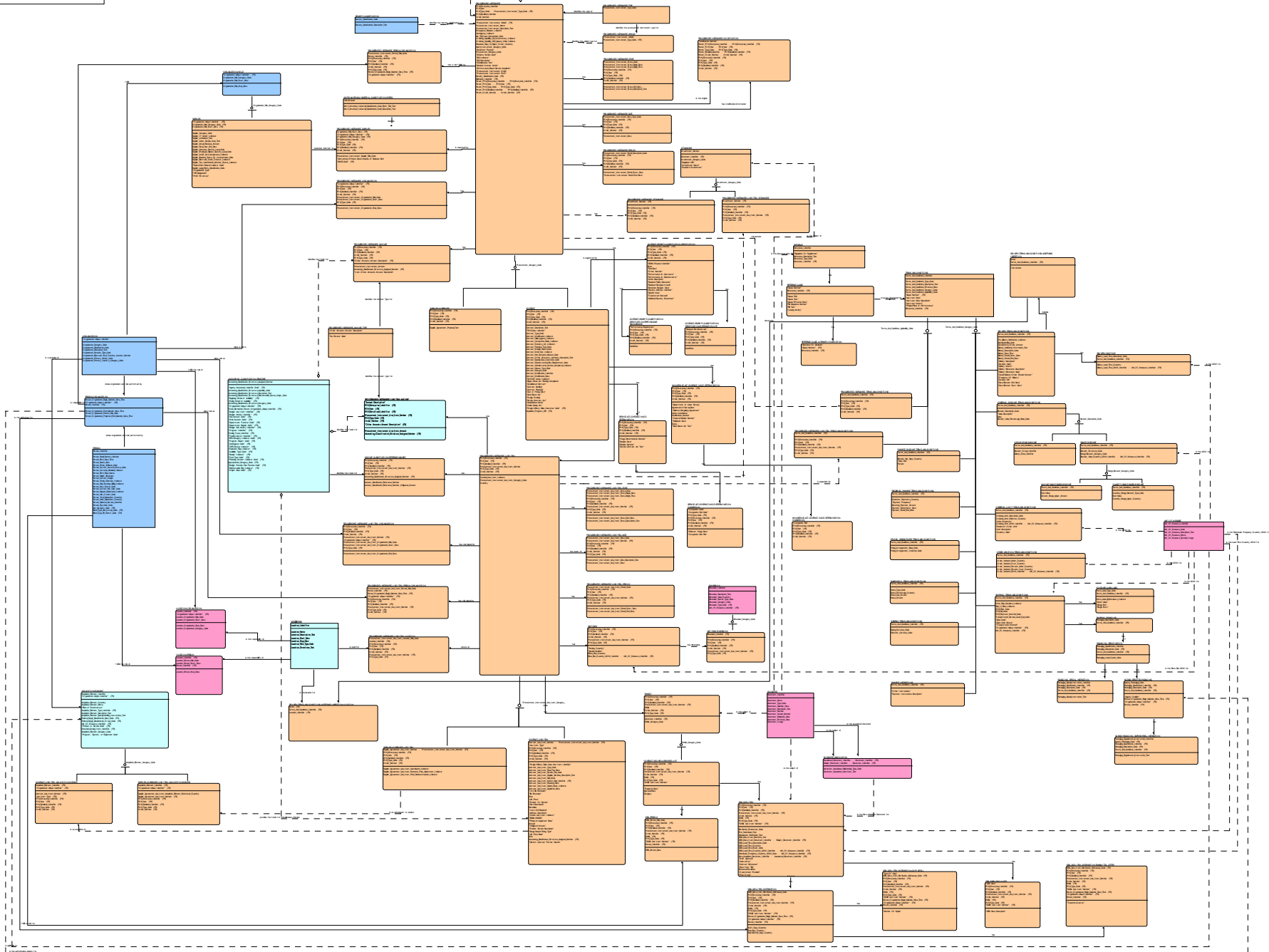

Product Hazard Data

1. This document is the property of the company and is to be used only for the purposes stated herein. It is not to be distributed outside the company without the express written consent of the company. 2. This document is to be used only for the purposes stated herein. It is not to be used for any other purpose. 3. This document is to be used only for the purposes stated herein. It is not to be used for any other purpose.

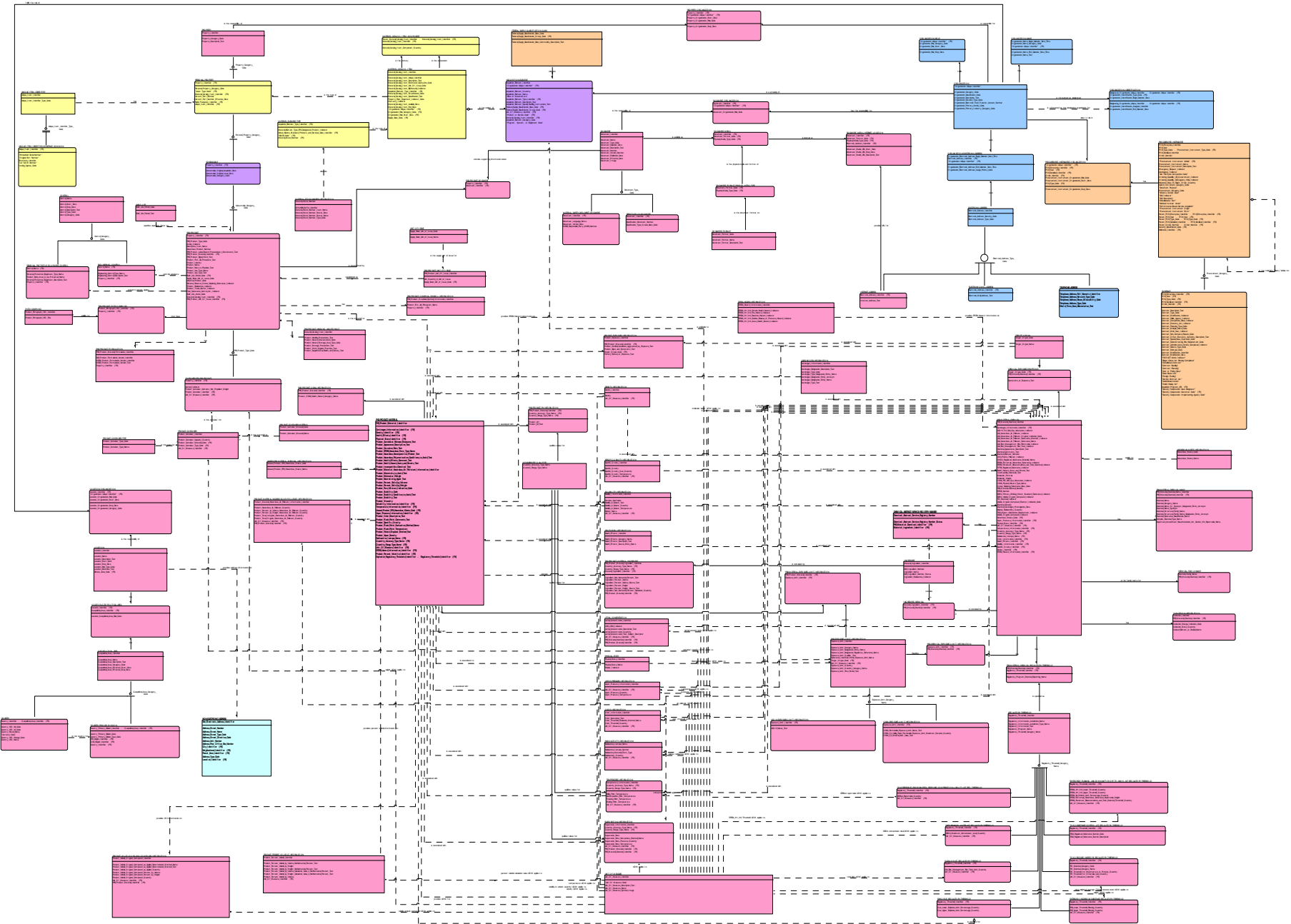

Real Property Asset Accountability
08/2012

Real Property Asset Accountability

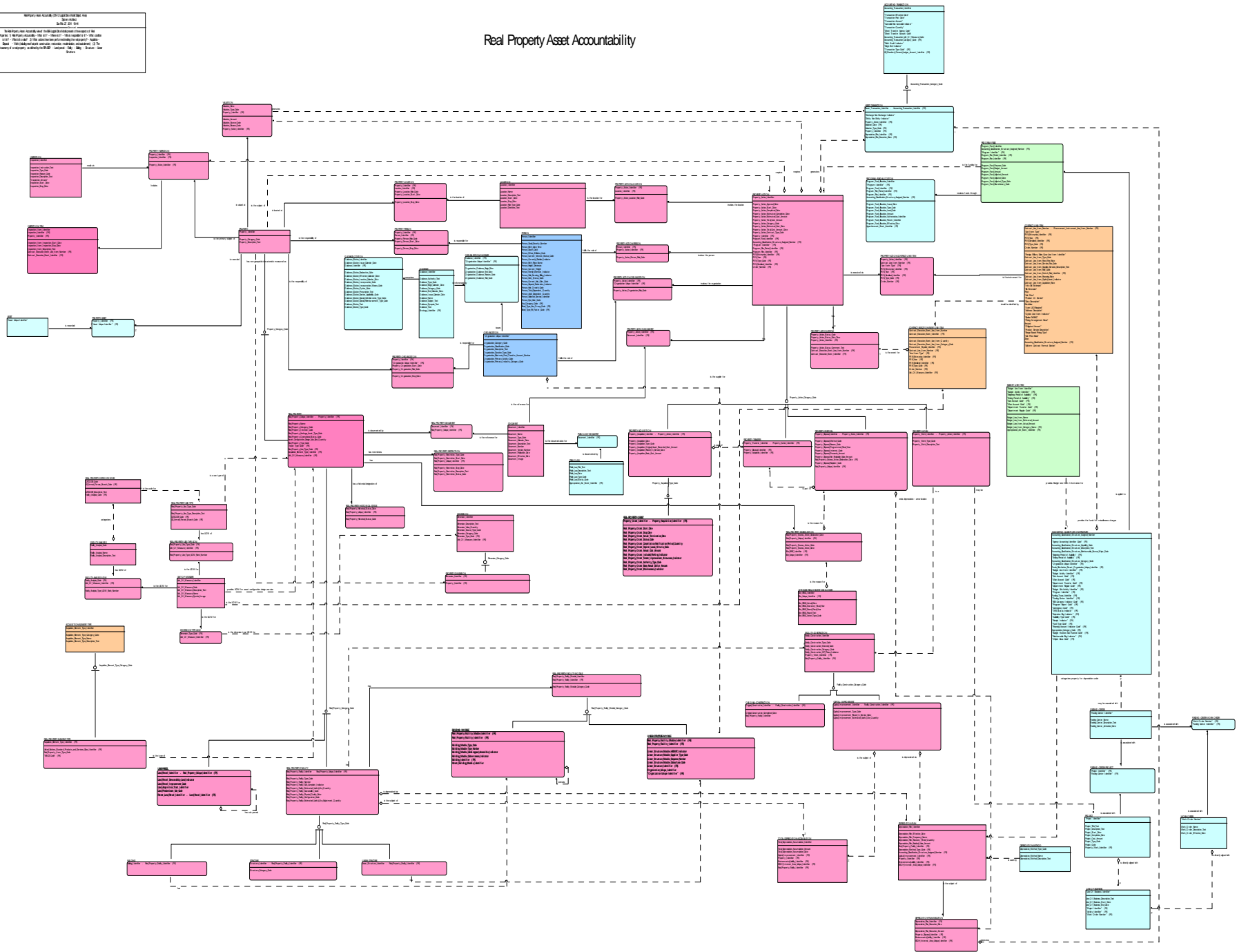

Receipt and Acceptance

1. The purpose of this document is to provide a clear and concise overview of the Receipt and Acceptance process. It is intended for use by all staff involved in the process, from the initial receipt of goods to the final acceptance and recording.

2. This document is a living document and will be updated as the process evolves. It is the responsibility of the relevant staff to ensure that the document is kept up to date and that any changes are communicated to all relevant staff.

3. The Receipt and Acceptance process is a critical part of the supply chain and is essential for ensuring that goods are received in the correct quantities and quality. It is also essential for ensuring that the correct records are kept for all receipts and acceptances.

4. The Receipt and Acceptance process is a multi-step process that involves the receipt of goods, the inspection of goods, the recording of goods, and the acceptance of goods. Each step is described in detail in this document.

5. The Receipt and Acceptance process is a key part of the supply chain and is essential for ensuring that goods are received in the correct quantities and quality. It is also essential for ensuring that the correct records are kept for all receipts and acceptances.

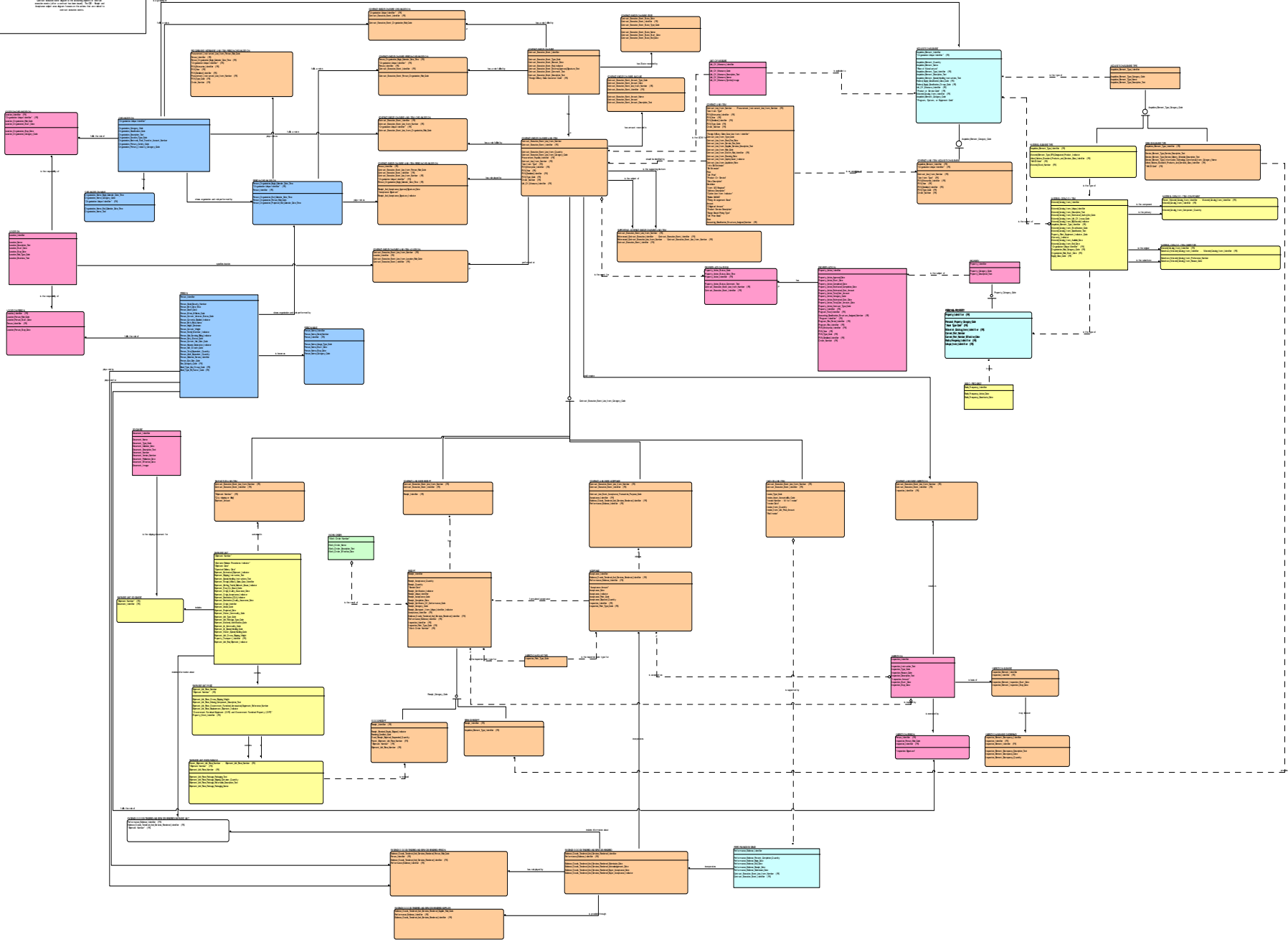

Referred Debt Cross Servicing (Q7 Logical Data Model Subject Area)
 System Object
 Tue Feb 16, 2010 21:12
 Comment
 This is the referral of debt to external sources for collection. This includes referral of uncollected debts to Department of the Treasury Cross Servicing.

Referred Debt Cross Servicing

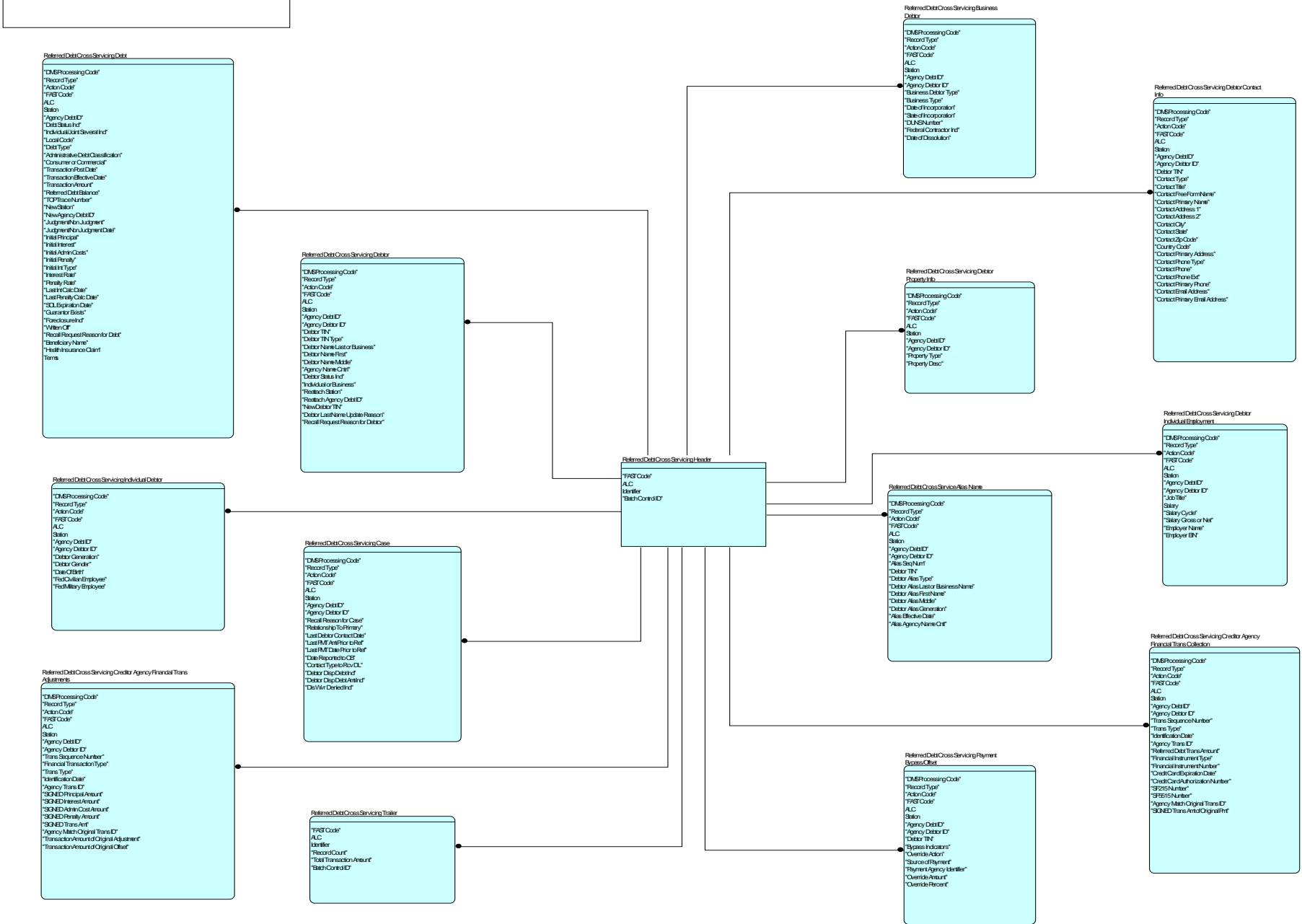

Referred Debt TOP

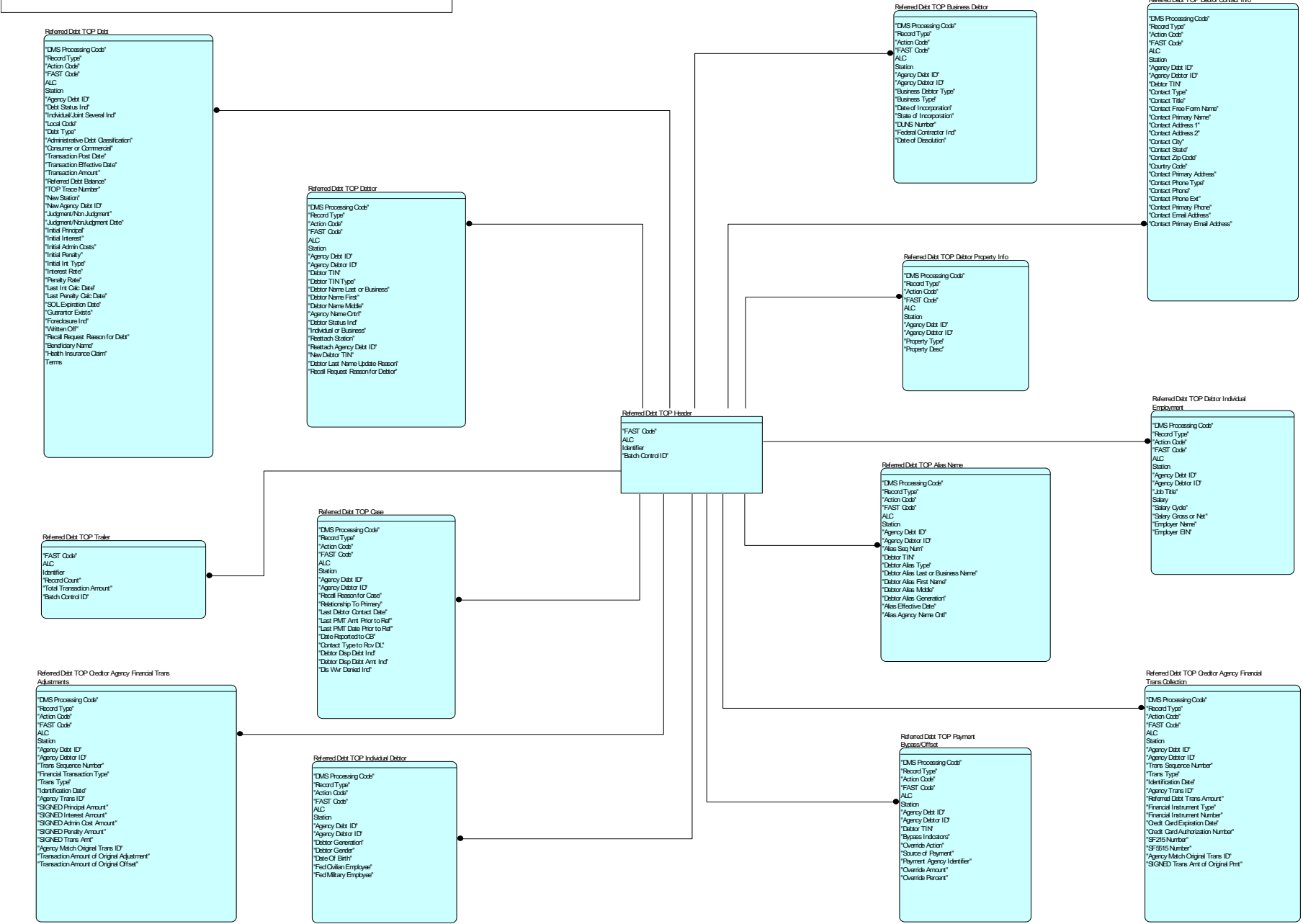

Requestor USEExports (Dk-2/Logical Data Model Subject/Rev)
 System Architect
 Sun Feb 27, 2011 19:49
 Comment
 This view shows the data collaboration necessary to track a USEExport License through the DoD review process. Information captured includes the review schedule, points of contact, and the status associated with each review stage.

Request for US Exports

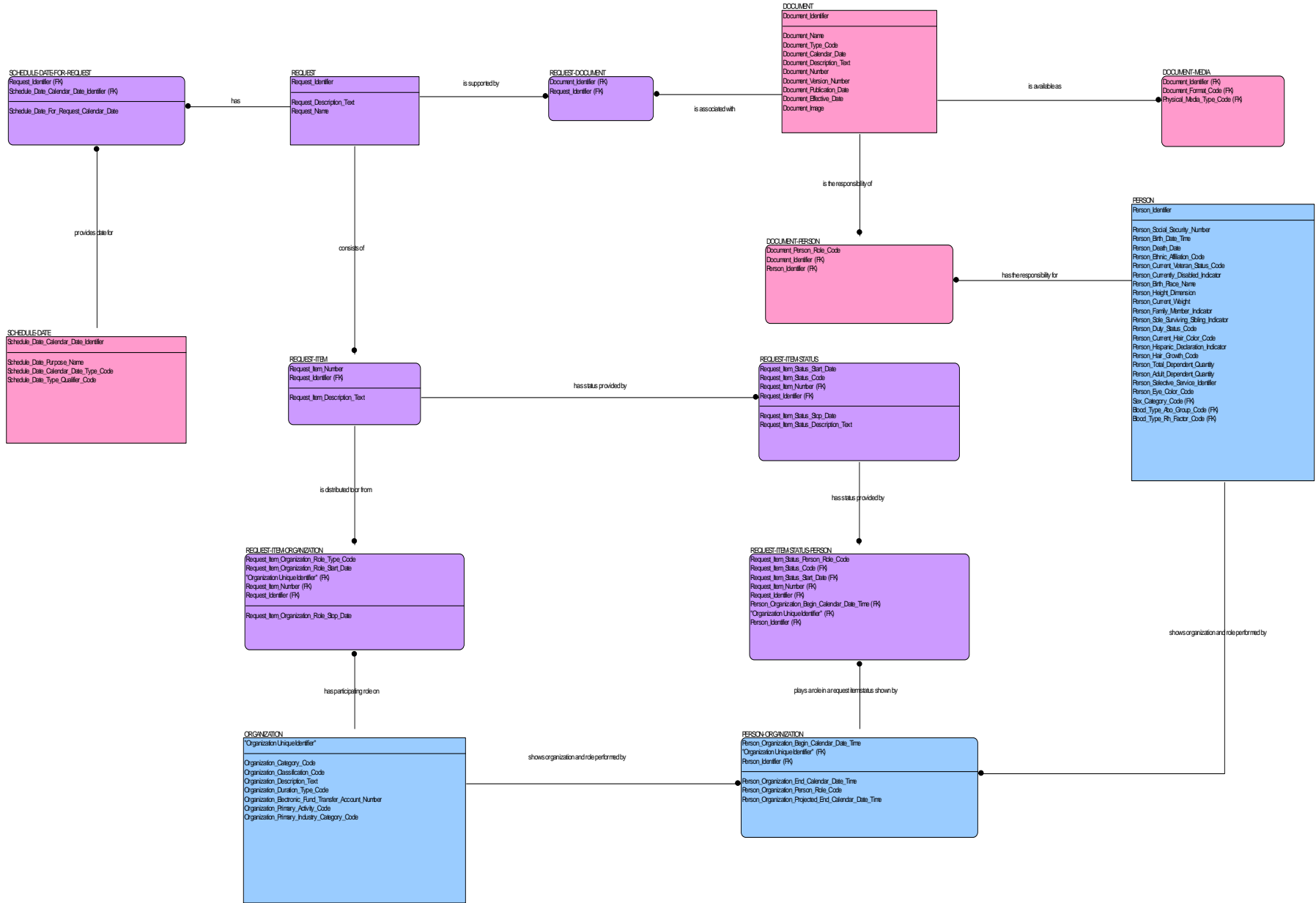

MEMBER OF THE BOARD OF DIRECTORS
MEMBER OF THE BOARD OF DIRECTORS
MEMBER OF THE BOARD OF DIRECTORS

Solicitation

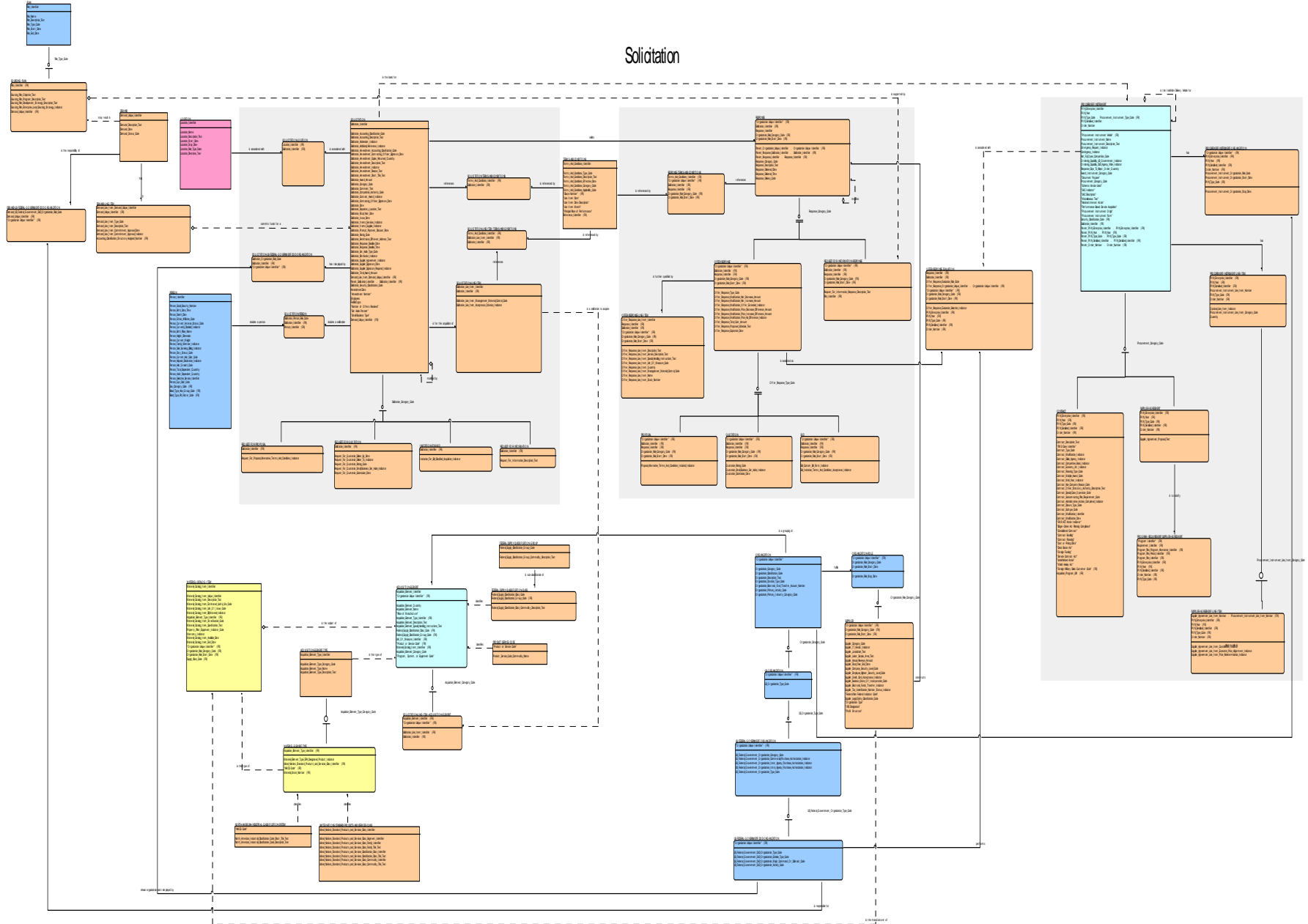

Standard Financial Information Structure

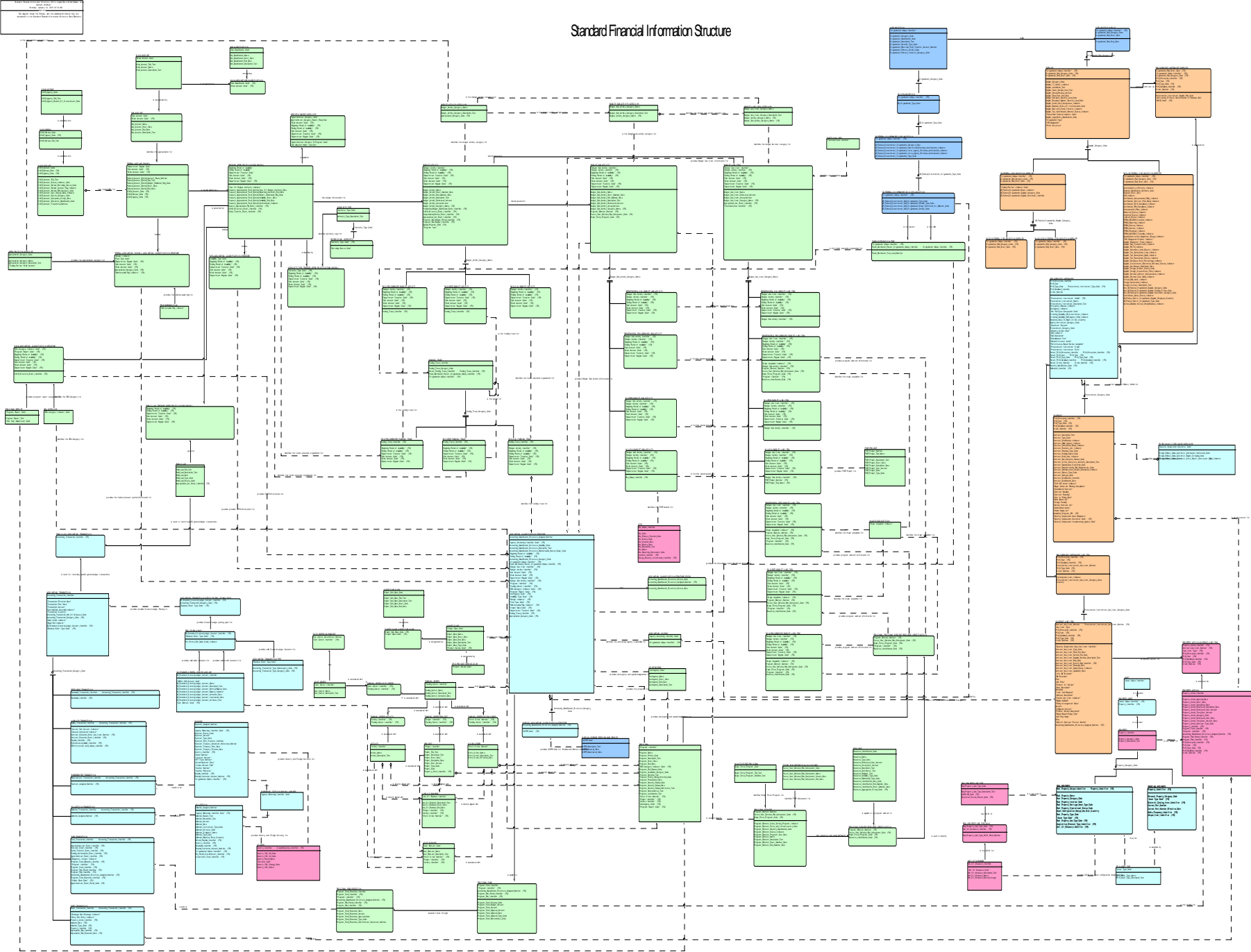

Supplier

